

• Behind the News • Health • UFOs • Future Science •

# NEXUS

NEW TIMES • Vol 9, N° 6

OCTOBER – NOVEMBER 2002

AUSTRALIA (incl. GST)	\$5.95
NZ (incl. GST)	NZD \$5.95
USA	USD \$4.95
UK	STG £2.80
EU	€4.05

**Climate Change:  
man-made or natural?**

**The rise and rise  
of Corporate Rule**

**Is your carpet toxic?**

**Mystery and majesty:  
Crop Circles of 2002**

**Ultrasound scans:  
cause for concern**



Print Post Approved PPS 116/0005

• Naked Singularities • Death by Doctoring Pt 2 •

# NEXUS

NEW TIMES MAGAZINE

Volume 9, Number 6 OCTOBER – NOVEMBER 2002

PO Box 30, Mapleton Qld 4560, Australia

Website: <http://www.nexusmagazine.com>

## CONTENTS

<b>LETTERS TO THE EDITOR.....</b>	<b>4</b>	<b>THE DOTTO RING—Part 2.....</b>	<b>53</b>
<b>GLOBAL NEWS.....</b>	<b>6</b>	<i>By Dr Gianni Dotto, with notes from Jerry Decker. Knowledge of the structure and function of DNA and RNA is necessary if we're to understand how an inductive coil like the Dotto Ring can recharge cellular energy levels and promote longevity.</i>	
<i>News you may have missed, including the Earth's growing equatorial gravity field, the Russian Duma's concern over HAARP experiments, and the US Space Command's plan to weaponise space.</i>		<b>THE PICK OF THE 2002 CROP CIRCLES.....</b>	<b>59</b>
<b>CORPORATE RULE AND POPULAR PROTEST.....</b>	<b>11</b>	<i>By Andy Thomas. The season was slow to start in England, but it brought forth some beautiful circular formations and a few surprises, including a depiction of an ET holding out an inscribed disc.</i>	
<i>By Richard Heinberg. This short history of how corporations came to rule looks also at the rise of the anti-globalisation movement with reference to the American Populist movement of the 1890s.</i>		<b>THE TWILIGHT ZONE.....</b>	<b>65</b>
<b>ULTRASOUND: NOT SO SAFE AND SOUND.....</b>	<b>17</b>	<i>Paradigm-expanding items, including research into alleged alien artifacts kept in the US Capitol in the late 1930s, leaked documents that shed light on official secrecy surrounding UFOs, and a report on the massive walls being constructed around Giza.</i>	
<i>By Dr Sarah J. Buckley. It's been promoted as being risk-free and giving peace of mind to prospective parents, but ultrasound's biological and psychological track records are far from glowing.</i>		<b>REVIEWS—Books.....</b>	<b>71</b>
<b>THE IPCC's ARTFUL BIAS ON CLIMATE CHANGE.....</b>	<b>23</b>	<i>"Vital Signs" by Andy Thomas</i>	
<i>By David E. Wojick, PhD. UN scientific reports mislead policymakers and the media into thinking that planetary climate change is solely the result of human interference rather than natural variation.</i>		<i>"Secrets in the Fields" by Freddy Silva</i>	
<b>DEATH BY DOCTORING—Part 2.....</b>	<b>33</b>	<i>"Stargate Chronicles" by Joseph McMoneagle</i>	
<i>By Steven Ransom. Vitamins C and B17 (also known as laetrile) have a history of success in cancer prevention and treatment, and a history of suppression by the medical orthodoxy.</i>		<i>"The Best Democracy Money Can Buy" by Greg Palast</i>	
<b>UNCOVERING THE FACTS ON TOXIC CARPET.....</b>	<b>39</b>	<i>"Conversations with the Body" by Robyn Elizabeth Welch</i>	
<i>By Jenny Hawke. Carpets, both old and new, pose serious hazards to health because they offgas volatile chemical compounds, trap dust mite allergens and act as a sink for heavy metal residues.</i>		<i>"The Biology of Transcendence" by Joseph Chilton Pearce</i>	
<b>SCIENCE NEWS.....</b>	<b>47</b>	<i>"Evidence: The Case for NASA UFOs" by David Sereda</i>	
<i>By Carl Hollingsworth and Henry Hallmon. Based on the geometry of the "naked singularity", this new model of physical organisation has the same rules for an entire galaxy as for a single cell.</i>		<i>"Looking for Orthon" by Colin Bennett</i>	
		<i>"The Round Towers of Atlantis" by Henry O'Brien</i>	
		<i>"Before the Flood" by Ian Wilson</i>	
		<i>"The Wild Genie" by Alexandra Pope</i>	
		<i>"UFOs and the National Security State" by Richard M. Dolan</i>	
		<i>"Battling Big Business" edited by Eveline Lubbers</i>	
		<i>"AIDS: A Second Opinion" by Gary Null, PhD</i>	
		<b>REVIEWS—Video.....</b>	<b>78</b>
		<i>"Michael Moore, Live in Santa Rosa, March 4, 2002"</i>	
		<b>REVIEWS—CD-ROM.....</b>	<b>78</b>
		<i>"Suil's Island" by Telma G. Dufton</i>	
		<b>REVIEWS—Music.....</b>	<b>79</b>
		<i>"Moffou" by Salif Keita</i>	
		<i>"Deep Space" by Japetus</i>	
		<i>"The Gift" by Hassan Hakmoun</i>	
		<i>"Return to Serenity" by various artists</i>	
		<i>"Windseeker" by Tony O'Connor</i>	
		<b>NEXUS BOOKS, VIDEOS, ADS, SUBS.....</b>	<b>87-96</b>

# NEXUS MAGAZINE

Volume 9, Number 6

OCTOBER – NOVEMBER 2002

PUBLISHED BY

NEXUS Magazine Pty Ltd, ABN 80 003 611 434

EDITOR

Duncan M. Roads

CO-EDITOR

Catherine Simons

ASSISTANT EDITOR/SUB-EDITOR

Ruth Parnell

EDITORS' ASSISTANT

Richard Giles

OFFICE ADMINISTRATOR

Jenny Hawke

CONTRIBUTORS THIS ISSUE

Richard Heinberg; Steven Ransom;  
David E. Wojick, PhD; Jenny Hawke;  
Dr Sarah J. Buckley; Carl Hollingsworth and  
Henry Hallmon; Dr Gianni Dotto and  
Jerry Decker; Andy Thomas

CARTOONS

Phil Somerville

COVER GRAPHIC

John Cook, jscook@ozzinet.net

PRINTING

APN, Queensland, Australia

AUSTRALIAN DISTRIBUTION

Newsagents Direct Distribution

HEAD OFFICE – All Correspondence

PO Box 30, Mapleton, Qld 4560, Australia

Tel: +61 (0)7 5442 9280; Fax: +61 (0)7 5442 9381

Email: [editor@nexusmagazine.com](mailto:editor@nexusmagazine.com)

Website: <http://www.nexusmagazine.com>

NEW ZEALAND OFFICE

RD 2, Kaeo, Northland

Tel: +64 (0)9 405 1963; Fax: +64 (0)9 405 1964

Email: [nexusnz@xtra.co.nz](mailto:nexusnz@xtra.co.nz)

USA OFFICE - 2940 E. Colfax, #131,

Denver CO 80206

Tel: +1 (303) 321 5006; Fax: +1 (720) 941 9352

Email: [nexususa@earthlink.net](mailto:nexususa@earthlink.net)

UK OFFICE - 55 Queens Rd, East Grinstead, West

Sussex, RH19 1BG. Tel: +44 (0)1342 322854;

Fax: +44 (0)1342 324574

Email: [nexus@ukoffice.u-net.com](mailto:nexus@ukoffice.u-net.com)

EUROPE OFFICE - PO Box 372, 8250 AJ Dronten,

The Netherlands. Tel: +31 (0)321 380558;

Fax: +31 (0)321 318892

STATEMENT OF PURPOSE

NEXUS recognises that humanity is undergoing a massive transformation. With this in mind, NEXUS seeks to provide 'hard-to-get' information so as to assist people through these changes. NEXUS is not linked to any religious, philosophical or political ideology or organisation.

PERMISSION-TO-REPRODUCE POLICY

While reproduction and dissemination of the information in NEXUS is actively encouraged, anyone caught making a buck out of it, without our express permission, will be in trouble when we catch them!

## Editorial

It never ceases to amaze me how people can have such strong opinions about things they know nothing about! I have lost the respect of more than one "friend" simply because I've published information they don't agree with. And this is not information they have checked, mind you, but information they don't *want* to agree with.

Sometimes I hear from people saying that they think our health articles are cutting-edge, but asking why we have to put UFO material in the same issue and destroy our credibility. Then there are letters from UFO researchers saying that they find the alternative health articles depressing. It is a shame they can't see how interrelated it all is.

Recently I've engaged in debate (on various subject-specific discussion lists like CIA-drugs) with people who happily believe that elements of the US intelligence community organised the September 11 attacks via remote-controlled planes and then destroyed the towers using secret Tesla-type weapons, but cannot possibly consider that AIDS is man-made or that HIV doesn't cause AIDS (see previous NEXUS articles). I've come across some leading conspiracy researchers who drink Diet Coke, think vaccinations are safe and effective, and eat junk food from fast-food outlets. And I've debated with science intellectuals who (correctly) tell me that the man-made climate change theory is bogus, but who also insist that UFOs cannot possibly exist because "nothing can go faster than the speed of light".

Closed-minded attitudes can be found as much among the "alternative" as the "mainstream" researchers. I remember being at one prestigious UFO conference in Sydney in the early 1990s, where a particularly well-known UK-based UFO researcher told the stunned audience that the only genuine crop circles are the round ones, because UFOs are round and would therefore leave only circular impressions in the ground. According to her viewpoint, this meant that all the complex formations were man-made and therefore hoaxes!

This issue, we have a round-up of our favourite formations from the latest crop circle season. Some interesting trends: there were fewer formations in the UK, but more in other European countries; and there were several pictorial images, including the most mysterious formation yet—an alien holding out a message in ASCII code. If you are reading this and you think that all crop circles are hoaxes, think again. There are plenty of stunning formations which would have been impossible for people to create on site.

I have spent an increasing amount of time over the years examining climate change research. A longstanding greenie, I was among the first to yell out about the ozone hole and greenhouse effect. In fact, when I first told friends and colleagues about the ozone hole back in the early/mid-1980s, I may as well have been talking about UFOs for all the looks of disbelief they gave me. And now, as with so many other subjects—Sai Baba, soybeans and so on—I find myself at odds with the opinions I had before I actually researched further. Certainly, the climate is changing and we continue to pollute the air and water (which should not be happening), but I find problems with the theory that human interference is the sole cause of climate change.

In my view, the climate change that the planet is experiencing is triggered by solar activity (the current solar maximum should have begun to wane two years ago but continues to peak). This in turn excites the Earth's magnetic field, which in turn triggers increasing levels of seismic and volcanic activity, which in turn causes the real climate change. I also suggest that underwater volcanism is a much more significant contributor to changes in ocean temperatures and currents than is generally recognised.

It seems that the greenhouse/global warming scenario has been hijacked by (mostly European-based) transnationals who are intent on using the Kyoto Protocol to subjugate the industries of other nations while their own flourish. It would be better if such treaties could enforce measures *now* against the toxic chemicals that are killing life on this planet, rather than allow nations to continue to engage in economic bullying over still-disputed climate change theories. There has certainly been intentional misrepresentation of the actual scientific data regarding climate change, prior to its circulation to policymakers, the media and environment groups. In this issue, we present a critique of the false statistics issued by the UN IPCC's scientific advisers. We also intend to keep examining "man-made" versus "natural variation" theories in future editions.

I also recommend that you read the article on corporations and popular protest. Corporations are a relatively new phenomenon historically, but already their internal economies eclipse the GDP of many a nation. They are all-powerful, and they answer to no one—except millions and millions of insignificant little consumers... Remember, we *can* make a difference!

Duncan

## WARRANTY AND INDEMNITY

Advertisers upon and by lodging material with the Publisher for publication or authorising or approving of the publication of any material INDEMNIFY the Publisher and its servants and agents against all liability claims or proceedings whatsoever arising from the publication and without limiting the generality of the foregoing to indemnify each of them in relation to defamation, slander of title, breach of copyright, infringement of trademarks or names of publication titles, unfair competition or trade practices, royalties or violation of rights or privacy AND WARRANT that the material complies with all relevant laws and regulations and that its publication will not give rise to any rights against or liabilities in the Publisher, its servants or agents and in particular that nothing therein is capable of being misleading or deceptive or otherwise in breach of the Part V of the Trade Practices Act 1974. All expressions of opinion are published on the basis that they are not to be regarded as expressing the opinion of the Publisher or its servants or agents. Editorial advice is not specific and readers are advised to seek professional help for individual problems.

© NEXUS New Times 2002



# Letters to the Editor ...

## Hurricane Andrew Cover-up

I just read a bit about hurricane Andrew on the website. It sure brought back memories.

I am a ham radio operator and I was a Red Cross volunteer in West Palm Beach at the time. My post during the expected hurricane arrival was a fire station in a western part of the county. When we heard news that the hurricane had hit further south, I contacted our local EOC [Emergency Operations Center] and requested permission to drive down to South Dade to assist. I was told by the head of our EOC that the conditions down south were not that serious, they needed no volunteers, and if I went I would be arrested.

This contradicted what I had been hearing from surviving ham radio operators so I loaded up with supplies, hooked my trailer with generator and fuel in tow, put my Red Cross ID on the dashboard and drove on down to what was left of Homestead.

I reported in to the Red Cross operation and, since I had brought extra communications equipment, they had me report to the city hall where I set up radio equipment so they could communicate.

My generator was quickly confiscated by the commander of the troops manning the National Guard building. They used it to run lights until they could manage to get utility power restored to the building. We had the use of the main building of the National Guard to use as storage and there were trucks coming in from the north that were carrying food and water.

Before long the building was getting filled, and they came over and asked the man that appeared to be in charge (I think he was city manager) at the city hall what they could do with all of the incoming food and water. I advised him that we could have Red Cross volunteers drive out into the community to deliver food and water to the people. He told me to see him in the morning and he would organise it.

For days we went out into all the areas we could reach by car or truck, distributing food, water, baby formula and other supplies. In that time I saw many devastated mobile home parks, homes and apartment buildings. In the wreckage, mostly the mobile home parks, the bodies

and body parts were all over and the stench was getting bad.

We were ordered to stop our food deliveries by the military after a few days because they claimed it was a health hazard for us to go out into these areas, and they wanted hunger to force the survivors to come out of the areas instead of remaining in their homes. The military set up kitchens at major intersections and prepared meals for anyone lucky enough to be near one or have transportation.

There was no discussion of any rescue efforts that I was aware of, and the Red Cross volunteer in the hospital reported that the only wounded coming in were people who came to the hospital on their own.

I remained and helped with a temporary tower and maintained a site running by generator for two-way communications and mobile telephone service. I even had to patch phone lines along the streets to try to keep the phone circuits to the tower working as long as possible until new lines and towers could be set up. I had to endure the martial law and I had guns pointed at me many times at the many military road blocks—but I was never arrested, as the head of the Palm Beach County EOC had claimed.

In fact, everyone I met at the local level in Homestead, with the exception of the military, was glad for the help we provided. Red Cross HQs, on the other hand, were lost in a mass of confusion. We had virtually no support from them. It was mostly individual volunteers like me, who ignored the warnings and turned up to help out, that ended up doing most of the ground work, and there were too few of us to go around.

I have absolutely no doubts about the cover-ups. I saw the bodies, and when I heard the "official" death reports I knew right then and there something was up.

Well, I've rambled on long enough. I have tried to put a lot of what I saw behind me. It was like a war zone I doubt I will ever forget.

Bob B., USA

## Sai Baba: Grace Disgraced

Dear Duncan: As one of the core contributors to the petition drawing attention to the allegations against the southern Indian spiritual teacher

(so-called) Sathya Sai Baba, it is very much in the mind of so many former Sai devotees that NEXUS did a very seminal and influential coverage of Sai Baba in 1999 [see 7/05]. I would therefore turn again to NEXUS to draw attention to our petition for official investigations of Sathya Sai Baba and his worldwide organisation. It is found at:

<http://www.PetitionOnline.com/saibaba/petition.html>.

In some cases, those of us closely involved in the exposure of Sathya Sai Baba feel that we have made some real ground, as can be seen at the many websites on this subject springing up on the Internet, e.g.:

<http://www.saiguru.net/english/>  
<http://www.sathyasaivictims.com/>  
<http://www.exbaba.com>.

However, devotees like Indian Prime Minister Vajpayee and many others right across party-political divisions, as well as the police and the judiciary, continue to support and cover up for Sai Baba and the leaders of his multibillion-dollar worldwide organisation.

Besides UNESCO, we now have many leading media taking our case seriously in countries such as USA, UK, Denmark, Sweden, The Netherlands, Germany, India, Australia and Canada. This is especially so in the case of countries whose nationals have provided affidavits and other credible testimony of sexual abuse upon male minors and young men by Sathya Sai Baba. There are excellent TV documentaries produced by the Danish Broadcasting Company and Argentinian television.

Even though UNESCO has posted a media advisory mentioning the serious reports of sexual abuse by Sai Baba and malfeasance by his leading officials, and though the US State Department has posted a travel warning which does all but name Sai Baba, governments including those of Australia, UK, Canada, Germany, The Netherlands and others who have been approached at the highest levels have still failed to act in protection of their citizens.

Thanks for a great magazine that demonstrates rationally that not all conspiracy notions are loopy. You are welcome to publish my email address.

Best regards,

Barry Pittard, Qld, Australia,  
[bpittard@beachaccess.com.au](mailto:bpittard@beachaccess.com.au)

## Dumbing Down by the Media

I've been reading the magazine for about three years now, and it has expanded my world view considerably. Although I have always been interested in what are wrongly labelled "alternative" news issues, NEXUS, unlike a lot of other sources, is non-judgemental (mostly). For instance, the content of *Fortean Times* has descended from a genuinely interested position to that of a "weird but true" section at the back of a Sunday newspaper, at the same time sniping at other magazines including NEXUS.

Have you noticed how demonised the Internet has become in the last year or so? From the greatest benefit to freedom and humankind, it is now the lair of perverts, terrorists and loners. At the same time, when the societies of the world seem more likely than ever to tip over, the news agencies are dumbing down more than ever.

Richard M., United Kingdom

## Proof of Faked Apollo Footage!

Dear NEXUS: I believe I have found the most conclusive evidence to support the theory that the *Apollo* missions to the Moon were hoaxed; in fact, I have proved it. I detail this below.

I live in London and recently saw a documentary which showed the *Apollo* footage doubled in speed, giving the appearance of Earthlike gravity. Quite apart from demonstrating that NASA could have filmed on Earth and halved the speed, there is much more here.

To increase the speed by a factor of two and achieve the appearance of Earthlike gravity means the gravity on the Moon is one quarter of that on Earth—but it is not; it is one sixth. Thus, to achieve Earthlike gravity would require increasing the speed of the footage by the square root of six: approx 2.45.

In order to prove that the videos were not shot on the Moon, you need to observe the footage from *Apollo XV*, where David Scott demonstrates the Galilean principle by dropping a hammer and a feather to the ground in a vacuum, i.e., on the Moon. The hammer is in freefall for at most 1.1 seconds. The distance it would therefore travel is:

$$0.5 \times \text{gravity} \times \text{time} \times \text{time} = \\ 0.5 \times (9.8/6) \times 1.1 \times 1.1 = 0.99.$$

Thus the hammer could not have

# ... more Letters to the Editor

**NB: Please keep letters to approx. 150 to 250 words in length. Ed.**

fallen a distance of more than 99 cm, or 0.99 m.

I have not been able to find David Scott's height; however, looking at photographs, he is clearly taller than Armstrong, who is 5'11", by several inches. David Scott is also wearing "Moon boots". The hammer is dropped by David Scott from shoulder height, easily 150 cm, or 1.5 m. This is not possible. David Scott cannot have been standing on the Moon when he dropped the hammer.

However, if we assume that NASA did indeed film the action on Earth, then halved the film speed, the distance the hammer would travel is:

$$0.5 \times 9.8 \times 0.55 \times 0.55 = 1.48 \text{ m} = 148 \text{ cm.}$$

I rest my case!

My calculations have been verified by several of my friends who are maths geeks like myself, and I hope you will also verify them. I look forward to hearing from you.

Mr Freedom, anonanon20071969@hotmail.com

## Bacteriophages & Urine Therapy

Hi, Duncan: It occurs to me, in the light of recent publicity on the history of successful use of bacteriophages in the USSR and now her ex-states as an alternative to antibiotics (BBC program, shown on 27 July 2002), that no one has mentioned that this could be a partial reason for the healing effects of urine therapy [see article in 9/04].

Bacteriophages are present in large numbers in the urine of patients in the convalescent stages. Being viruses, they are not filtered out as are the bacteria and would be specific for that particular illness, so would help recovery enormously—or so the theory goes! Any feedback on self-help using this method would be very interesting.

Julian Braggins, j\_braggins@austarnet.com.au

## Noni Juice: A Magical Cure-All?

Dear Duncan: I have been reading NEXUS for many years and enjoy the variety of articles.

My mother has terminal cancer, and I was recently introduced to a product called Noni juice. I had not heard of it before, so conducted my own research. There is a lot of information on the Net and various books from users and doctors with

varying testimonies.

My mother has improved slightly after taking the tonic for about four weeks, but only time will tell.

I would be interested in other readers' experiences with this "magical cure" for all diseases and ailments.

Regards,

Karen Townend, NSW, Australia, ktow7556@mail.usyd.edu.au

## Ethical Charities & Corporations?

Hello, Duncan: Thanks to you and your team for a great magazine. I've been buying it for the last ten years and will be buying it for the next ten as well.

The only thing I would really like to see in the mag (that I don't recall ever having seen) is an article about charities. I always used to give a percentage of my money (not a lot, since I was unemployed) to certain charities with the sincere hope that I was making a little difference in the world and making things better for the world in general, but I have since stopped after hearing certain things—primarily, that some charities covertly support the opposite to what they purportedly are trying to help.

My father was in the Charity Commission in the UK and after having been there a few years said he would give money to very few of them. Are there any really honest and sincere charities out there? I would love to know more.

Also, I would like to see something on just how ethical many of our high-street names, manufacturers and supermarkets are (Coke, Reebok, McDonald's, etc.). I don't buy any of the above products, but I'm sure there are things I *do* buy that have some dubious ethical standards. I hate buying something, only to find out later that the manufacturers test on animals or pay next to nothing to their labourers in some African country.

I think it's important for people to know these things, and that by buying ethically sound goods we are making the world a better place while hopefully draining some of the power from major corporations who think they can treat living beings like crap just so they can make more money.

Thanks for reading.

Jim S., Wirral, United Kingdom

## Coconuts and Non-Vegetarianism

Dear Duncan: I am writing this to praise you highly and thank you for producing such a great and informative magazine. Bravo! I am getting a far more accurate and truthful education in history from NEXUS than I ever did in school. In fact, I believe the *real* conspiracy stories are in the mainstream media! My husband (a former PM) and I both love NEXUS magazine so much, we've just ordered two years of back issues along with our subscription request.

Also, I want to praise highly two recently published two-part articles: one on "The Myths of Vegetarianism" [see 9/03-4], and the other on "The Health Benefits of Coconuts" [9/02-3]. As an ND and writer specialising in nutrition for over 28 years, I have to say *both* articles were *excellent* and I agree totally with them! Both authors really did their homework. Bravo! Unfortunately, there is a *lot* of *misinformation* out there in the field of health and politics. Fortunately, these articles certainly help to expose the fallacies perpetrated and get to the scientific *truth* of the matter.

I am familiar with the many years of research done on fats by Dr Mary Enig (more than anyone else) and greatly respect it and her. As a matter of fact, I used her scientific papers as a reference several years ago when I wrote my article, "Know Your Fats", for *Let's Live* magazine.

Having lived in Polynesia for many years, I've seen first-hand the health benefits of coconuts consumed by the elders, and what happens when they are no longer consumed. Hence, I go out of my way to obtain coconuts while here in New Zealand, and I highly recommend them to my clients.

With regard to the myths of vegetarianism, this knowledge being relayed to the public is long overdue! Like Dr Byrnes, for years I too have witnessed the ill effects of a total vegetarian diet. Like so many others, I love animals and wish it were possible to be a vegetarian and be healthy—but unfortunately it isn't, because we are all part of the cycle of life here on Mother Earth! Dr Stephen Byrnes has addressed all these myths in a very professional and factual manner.

A reference both authors have used is from my favourite book, *Nutrition and Physical Degeneration* by Weston A. Price, DDS. It is a priceless treasure and no one can dispute his findings. All schools should make this mandatory reading instead of trying to hide it!

Duncan, keep up the *great* job! It is truly appreciated by not only me, but by so many of your readers throughout the world.

All good wishes,

Lady Carla Davis, ND, Hamilton, New Zealand

## US Agencies Identify Terrorists

Dear Sir: I am currently employed by the US Government as an intelligence analyst and felt I was doing my part on our "war on terrorism", until these past few months.

My brother recently purchased a copy of the video 9-11: *The Road to Tyranny*, and insisted I watch it. Although the entire video was disturbing, I especially remembered the segment which showed police officers sitting in a classroom and being told how our Founding Fathers were terrorists. I partially dismissed it as taken out of context, until the experience I just had.

The agency I work for just sent me to a week-long course, titled "Dynamics of Terrorism", which was hosted by the DoD Polygraph Institute. The first day of the course began in a usual manner with the instructors (two of them) introducing themselves and discussing their backgrounds. They were both NSA.

Then began a week-long introduction into what the FBI, NSA and our government classify as terrorism these days. Here's a condensed list: the teens who committed the school shooting at Columbine, the Branch Davidians, Randy Weaver, the Founding Fathers, computer hackers, militias, anyone who commits a "hate crime", and especially anyone who does not trust our government. I couldn't believe what I was hearing; it was almost verbatim out of the video. From what I could tell, several of the cops were having a hard time with the course, except for the bureau boys who seemed to be lapping it up. Just wanted to let you know about this...

Anonymous, USA, via InfoWars website, <http://www.infowars.com>

## CIVILIAN AND MILITARY ENVIRONMENTAL SATELLITES TO BE LINKED

A US\$4.5 billion contract has been awarded to TRW Inc. to build and deploy America's future environmental satellite system, using both military and civilian satellites.

The contract is for the acquisition and operations phases of the National Polar-orbiting Operational Environmental Satellite System (NPOESS).

The NPOESS will combine US military and civilian environmental satellite programs into a single national system that is designed to improve weather forecasting and climate prediction.

The National Oceanic and Atmospheric Administration (NOAA) has overall responsibility for the converged system as well as for satellite operations and interactions with the civil and international user communities. The Department of Defense has the lead responsibility for major systems acquisitions, including launch support. And NASA has primary responsibility for facilitating the development and incorporation of new, cost-effective technologies into the converged system.

NOAA Administrator Dr Conrad Lautenbacher said: "By working together on this advanced satellite system, the three agencies will make the nation's environ-



mental satellite system more efficient, cost-effective and more responsive to our country's environmental information needs. This new system will provide vital information about our weather, environment, climate and oceans. In addition, our integrated effort is expected to result in taxpayers saving approximately \$1.6 billion over the NPOESS lifetime."

TRW will develop, fabricate and deliver the NPOESS satellite and ground systems as well as provide launch support, operations and support services for the system. (Source: *Environment News Service*, August 28, 2002, <http://ens-news.com>; more details at <http://www.ipo.noaa.gov/>)

## EARTH'S CHANGING GRAVITY FIELD

Satellite data since 1998 indicates that the bulge in the Earth's gravity field at the equator is growing, and scientists now think that the ocean may hold the answer to the mystery of how the changes in the trend of Earth's gravity are occurring.

Before 1998, Earth's equatorial bulge in the gravity field was getting smaller because of the post-glacial rebound, or PGR, that occurred as a result of the melting of the ice sheets after the last Ice Age. When the ice sheets melted, land that was underneath the ice started rising. As the ground rebounded in this fashion, the gravity field changed.

"The Earth behaved much like putting your finger into a sponge ball and watching it slowly bounce back," said Christopher Cox, a research scientist supporting the Space Geodesy Branch at NASA's Goddard Space Flight Center, Greenbelt, Maryland, USA.

Currently, the Earth has a significant upward bulge at the equator and a downward bulge at the poles.

"Observations of the Earth's gravity field show that some phenomena are counteracting the gravitational effects of PGR. Whereas PGR has been decreasing the bulge in the Earth's gravity field at the equator, this recent phenomenon is causing the bulge to increase," Cox said.

"The three areas that can trigger large changes in the Earth's gravitational field are oceans, polar and glacial ice, and atmosphere," he added.

Cox and colleague Dr Benjamin Chao have ruled out the atmosphere as the cause, and estimates of current glacier and polar ice melting are too small to explain the recent changes in the gravity field.

"The recent reports of large icebergs calving in Antarctica can't explain this, because they were already floating in the ocean," Cox said.

Further, radar altimeter observations of the average sea level rise provided by the *TOPEX/Poseidon* satellite show *no corresponding change in the rate of the global sea level increase*. Consequently, mass must have been redistributed within the oceans. That's where the ocean circulation theory comes in.



Ocean currents can redistribute mass quickly, such as in the five-year time frame that these changes were first observed. The *TOPEX/Poseidon* observations of sea level height do show an increase in the equatorial bulge of the oceans corresponding to the observed gravity changes, but the data are not yet conclusive.

(Source: NASA's Goddard Space Flight Center press release, August 1, 2002, at website <http://www.gsfc.nasa.gov/topstory/20020801gravityfield.html>; also see Science, August 2, 2002)

## HAARP WEAPONS WORRY RUSSIAN DUMA

The Russian State Duma has expressed concern about the USA's program to develop a qualitatively new type of weapon.

"Under the High-frequency Active Auroral Research Program (HAARP), the USA is creating new integral geophysical weapons that may influence the near-Earth medium with high-frequency radio waves," the State Duma said in an appeal circulated on Thursday [August 8].

The significance of this qualitative leap could be compared to the transition from cold steel to firearms, or from conventional weapons to nuclear weapons. This new type of weapon differs from previous types in that the near-Earth medium becomes at once an object of direct influence and its component.

These conclusions were made by the commission of the State Duma's international affairs and defence committees, the statement reads.

The committees reported that the USA is planning to test three facilities of this kind. One of them is located on the military testing ground in Alaska, and its full-scale tests are to begin in early 2003. The second one is in Greenland and the third one in Norway.

"When these facilities are launched into space from Norway, Alaska and Greenland, a closed contour will be created with a truly fantastic integral potential for influencing the near-Earth medium," the State Duma said.

The USA's plans to carry out large-scale scientific experiments under the HAARP program, and not controlled by the global community, will create weapons capable of breaking radio communication lines and equipment installed on spaceships and

rockets, provoke serious accidents in electricity networks and in oil and gas pipelines and have a negative impact on the mental health of populations of entire regions, the deputies said. They demanded that an international ban be put on such large-scale geophysical experiments.

The appeal, signed by 90 deputies, has been sent to President Vladimir Putin, to the United Nations and other international organisations, to the parliaments and leaders of UN member countries, and to scientists and the mass media outlets.

(Source: Interfax News Agency, Moscow, August 9, 2002; via Dr Nick Begich, EarthPulse Press, website <http://www.earthpulse.com>; also see website <http://server5550.iid.nrl.navy.mil/projects/haarp/>)

## UK LEADS THE WAY IN ERODING PERSONAL PRIVACY

Individual privacy is being eroded in Britain to a far greater extent than in other developed countries, according to an international study of state surveillance in the year since September 11.

Many states have rushed through restrictive anti-terrorism and security laws in response to last year's terrorist attacks, but the Blair government is singled out for an anti-privacy "pathology" that the report claims is leading to mass surveillance of the population.

In the 400-page report, due to be published on September 6, Privacy International, a London-based campaign group, and the US Electronic Privacy

Information Center give warning of a significant loss of personal freedom.

The Privacy and Human Rights survey notes that in many of the 53 countries studied, communications surveillance has grown, intrusive "personal profiling" of individuals has increased and data protection laws have been watered down.

"In the rush to strengthen national security and to reduce the risk of future terrorist acts, governments around the world turned to legal authority and new technology to extend control over individuals," the report states. "Many of these proposals have had far-reaching consequences for the protection of privacy."

The report highlights the British government's use of the terrorist threat to introduce new requirements for personal communications data to be stored and to launch a new debate about a national identity card.

David Blunkett, the Home Secretary, also sought in June to extend the Regulation of Investigatory Powers Act to allow private email and telephone records to be shared among more than 1,000 government agencies. After facing strong protests, Mr Blunkett withdrew the proposal a few weeks later and announced that he had "blundered".

Simon Davies, director of Privacy International, said the report highlights "a systematic attack on the right to privacy by all levels of the British government". He added: "The UK demonstrates a pathology of antagonism toward privacy. The rate of



"Yes, sonny, we are part of the global transcorporate military-industrial ruling cartel, but today we just wanna have fun."

growth of video surveillance, communications surveillance and information collection has exceeded the growth rate in such countries as Singapore and Israel."

The erosion of privacy in Britain is not a new trend. "Crime and public order laws passed in recent years have placed substantial limitations on numerous rights, including freedom of assembly, privacy, freedom of movement, the right of silence and freedom of speech," the report states.

It cites a number of illegal spying and surveillance activities by government agencies, often in violation of the European Convention on Human Rights, and estimates that 1.5 million CCTV cameras are now monitoring public spaces.

(Source: By David Rowan, The Times, London, September 5, 2002, website <http://www.timesonline.co.uk/>)

## BRITISH MoD PLANS TO SELL DIVISION TO CARLYLE GROUP

British government ministers have defended plans to sell part of the defence research industry to a US-based company that has several former international leaders on its payroll.

George Bush senior, his former Secretary of State James Baker, the former British Prime Minister John Major and many other figures from international big business and politics are employed by The Carlyle Group, a US-based private equity and defence group.

The government has dismissed union fears that the British national interest may be compromised by the influence of

diverse overseas lobbyists linked to the company. It announced earlier this week that Carlyle was the preferred bidder to take over its research and technology division, QinetiQ. The former defence research agency has developed missile-tracking software, radar technology and other defence systems.

Fiona Draper of the trade union Prospect, which represents scientists at QinetiQ, said: "The fact that they are a foreign company will obviously exacerbate my members' concerns; given Carlyle's fairly opaque structure, there must be concerns over whether undue influence may be brought to bear which may not be in Britain's interest."

In addition to the list of influential names from US politics, the company has been linked to the Saudi royal family and until last year maintained links with the half-brother of Osama bin Laden.

However, Defence Minister Lewis Moonie insisted that Britain's national interest would not be compromised by the partial sale of the agency. "It is very important that half-truths and shades like that should not be allowed to cloud the name of a respectable company and one we have investigated in great detail, as we have any other company with whom we would be going into partnership," he said.

The British government is selling off a significant stake in the agency, having dropped plans to float the company on the stockmarket earlier this year.

Like other private equity groups, Carlyle has a history of taking short-term stakes in

companies. Industry observers have predicted that the company would be likely to prepare QinetiQ for full sell-off within five years.

(Source: Guardian, London, September 5, 2002, <http://www.guardian.co.uk>)

## BELGIUM TO BAN FLUORIDE SUPPLEMENTS

Fluoride tablets, fluoride drops and fluoride chewing gum, for decades promoted as the crown jewels of dentistry, are going to be taken off the market in Belgium because they are poisonous and pose a great risk for physical and psychological health.

The usefulness and safety of fluoride has been doubted worldwide for a long time. At least 12 Nobel Prize winners in Medicine and Chemistry have warned of the associated health risks.

Research shows that fluoride can cause joint problems, skeletal deformations and osteoporosis, and can even cause bone cancer. Fluoride has a negative influence on the nervous system and the immune system, and in children it can lead to (chronic) fatigue, a lower IQ, learning disabilities, lethargy and depression.

Sodium fluoride, which is used in the so-called food supplements, is 80 times more poisonous than the naturally occurring calcium fluoride, with which it is often confused even by medical professionals.

And, not unimportantly, it is a poisonous waste product of the aluminium and artificial fertiliser industry. Multinationals like Exxon, US Steel and Alcoa can get rid of their waste totally legally—and they even get rich from it.

(Source: HUMO magazine, Belgium, no. 3230/32, July 30, 2002, at website <http://64.177.90.157/pfpc/html/humo.html>)

## COURT RULES AGAINST FARMER PERCY SCHMEISER

The Canadian Federal Court of Appeal has upheld a ruling that the Saskatchewan farmer Percy Schmeiser violated a patent held by Monsanto on a herbicide-resistant canola.

In March 2001, Mr Schmeiser was ordered to pay C\$19,000 in damages for using Roundup Ready canola. He was also ordered to cover Monsanto's court costs of \$153,000.

Percy Schmeiser had argued that either Roundup Ready canola seed blew into his field from a passing truck or his crop may



have been contaminated by pollination.

On Thursday September 5, the three-judge appeal court panel unanimously ruled in Monsanto's favour, dismissing all of Mr Schmeiser's 17 points of contention. However, the panel also rejected a bid by Monsanto to see the damages raised to more than \$100,000.

Mr Schmeiser was not available for comment, but his lawyer, Terry Zakreski, said his client was disappointed. "We're still reviewing it and considering whether to seek leave to appeal to the Supreme Court of Canada," he said.

Trish Jordan of Monsanto said the money Mr Schmeiser has been ordered to pay will be put into the corporation's fund to reinvest into the agricultural community as part of a larger corporate charity program. "We have always said we will not profit from people doing illegal things," she said.

Despite his loss in court, Mr Schmeiser has become somewhat of a folk hero among farm and consumer activists around the world who are opposed to genetically modified food and the use of GM organisms in agriculture.

(Source: *The Canadian Press, September 9, 2002, website <http://www.cp.org>*)

## US PRISON/CORRECTIONAL POPULATION AT 6.6 MILLION

The number of Americans in prison or under supervision by authorities as a result of crimes grew by 2.3 per cent by year-end 2001 to almost 6.6 million Americans, or one in every 32 adults, the US Department of Justice announced on Sunday [August 25].

The rise in the number of people in the US correctional system was slower than the 3.6 per cent average annual increase between 1995 and 2001, but the total number is a new high.

About three per cent of the US adult population is in the US correctional system. Of these, 1.3 million were in prison, while 631,240 were in jail, the Department said. There were 3.9 million on probation and 731,147 people on parole, according to the government's data. At year-end 2001, one in five probationers were women, while one in three were black.

(Source: *Reuters, August 26, 2002, <http://www.reuters.com/>; also see US DoJ Bureau of Justice Statistics releases at <http://www.ojp.usdoj.gov/bjs/>*)

## SPACE WEAPONS AND WORLD EMPIRE

by John Valleau

In 1997, the US Space Command published a mission statement titled "Vision for 2020" (see [http://www.spacecom.mil/\\_private/about\\_space.htm](http://www.spacecom.mil/_private/about_space.htm) and also <http://www.noos.ca> for more details). Since 1997, it has been joined by further documents fleshing out more details of the plan, such as a "Long Range Plan". (Note the date, 2020, which gives a time scale for our concerns.)

"Vision for 2020" sees outer space under the unilateral control of the United States and filled with weapons able to maintain this control and also able to attack the Earth below. The stated purpose is "dominating space" to "protect US interests and investment". This involves "control of space", meaning "access to space, freedom of operations within space, an ability to deny others the use of space" and also "global engagement", which is "the application of precision force from, to, and through space" as "an active warfighter" with "space-based earth strike weapons". Apparently, then, we are all meant to live not only under constant US surveillance, but under constant threat of violence from a blanket of space weapons. Most of us would consider this an indignity too great to be supported.

To what end? The purpose already quoted makes that quite clear: namely, the forceful control of the first whole-world commercial empire. This is driven home by what "Vision for 2020" calls an "historic perspective", which states that "...military forces have evolved to protect national interests and investments" and "during the rise of sea commerce, nations built navies to protect and enhance their commercial interests. During the westward expansion of the continental United States, military outposts and the cavalry emerged [*sic*] to protect our wagon trains, settlements and railroads", and so on. It goes on to say that "the emergence of space power follows...these models" (i.e., of former empires and of genocide).

This is only to confirm, in a surprisingly frank way, what has become the common worldwide understanding of the intense US pressure to impose the neo-liberal agenda and structural adjustment on Third World nations (and others)—namely, to facilitate the classic imperial aim of seizing the resources and exploiting the labour of less-developed countries, where possible with the help of puppet governments.

But imagine space with a blanket of orbiting surveillance equipment and space weapons such as particle-beam and laser devices, rocket and missile launchers, devices to disable electromagnetic equipment or to control the weather locally, and so on. With this, it would be possible to apply force locally and instantly, to choose just that level of pain deemed appropriate, and to do so with impunity. It would mark the end of local sovereignty and much of human dignity.

The role of the Ballistic Missile Defence (BMD) project can be seen, in this light, primarily as a stalking horse: a relatively benign-sounding excuse (after all, "defensive" and, anyway, certain to be ineffective) for abrogating an Anti-Ballistic Missile (ABM) Treaty that would otherwise stand in the way of the bigger plans.

However, there seems at last to be a growing awareness among US citizens of what has been going ahead in their name. One sign of this is the bill HR3616 presented to Congress by Dennis Kucinich (D-Ohio), which would prevent the US administration from proceeding to develop or put in place space weapons. Meanwhile, various US NGOs are pushing for a new international treaty banning all weapons from space.

Although the events of September 11 helped the Bush administration to forward its space agenda initially, the travesty of the Afghan "anti-terrorism war" is making people start to question the direction of US policy. There will certainly also be worldwide opposition to the imposition of US military domination of space as the intention becomes widely recognised. It is the right time to speak out for a civil world order and reject the threat of techno-tyranny.

(Source: *Global Outlook, 9-11: Foreknowledge or Deception?, no. 2, Summer 2002, at <http://globalresearch.ca/articles/VAL206A.html>. John Valleau is Professor Emeritus of Chemistry at the University of Toronto and an active member of Science for Peace.*)



# A HISTORY OF CORPORATE RULE AND POPULAR PROTEST

***A new populist movement has emerged to challenge corporate power and call for a more equitable economic order that protects traditional cultures and ecosystems and promotes sustainability.***

**by Richard Heinberg © 2002**

Editor/Publisher  
*MuseLetter*  
1604 Jennings Avenue  
Santa Rosa, CA 95401, USA  
Email: [heinberg@museletter.com](mailto:heinberg@museletter.com)  
Website: <http://www.museletter.com>

The corporation was invented early in the colonial era as a grant of privilege extended by the Crown to a group of investors, usually to finance a trade expedition. The corporation limited the liability of investors to the amount of their investment—a right not held by ordinary citizens. Corporate charters set out the specific rights and obligations of the individual corporation, including the amount to be paid to the Crown in return for the privilege granted.

Thus were born the East India Company, which led the British colonisation of India, and Hudson's Bay Company, which accomplished the same purpose in Canada. Almost from the beginning, Britain deployed state military power to further corporate interests—a practice that has continued to the present. Also from the outset, corporations began pressuring government to expand corporate rights and to limit corporate responsibilities.

The corporation was a legal invention—a socio-economic mechanism for concentrating and deploying human and economic power. The purpose of the corporation was and is to generate profits for its investors. As an entity, it has no other purpose; it acknowledges no higher value.

Many people understood early on that since corporations do not serve society as a whole, but only their investors, there is therefore always a danger that the interests of corporations and those of the general populace will come into conflict. Indeed, the United States was born of a revolution not just against the British monarchy but against the power of corporations. Many of the American colonies had been chartered as corporations (the Virginia Company, the Carolina Company, the Maryland Company, etc.) and were granted monopoly power over lands and industries considered crucial to the interests of the Crown.

Much of the literature of the revolutionaries was filled with denunciations of the "long train of abuses" of the Crown and its instruments of dominance, the corporations. As the yoke of the Crown corporations was being thrown off, Thomas Jefferson railed against "the general prey of the rich on the poor". Later, he warned the new nation against the creation of "immortal persons" in the form of corporations. The American revolutionaries resolved that the authority to charter corporations should lie not with governors, judges or generals, but only with elected legislatures.

At first, such charters as were granted were for a fixed time, and legislatures spelled out the rules each business should follow. Profit-making corporations were chartered to build turnpikes, canals and bridges, to operate banks and to engage in industrial manufacture. Some citizens argued against even these few, limited charters, on the grounds that no business should be granted special privileges and that owners should not be allowed to hide behind legal shields. Thus the requests for many charters were denied, and existing charters were often revoked. Banks were kept on a short leash, and (in most states) investors were held liable for the debts and harms caused by their corporations.

All of this began to change in the mid-19th century. According to Richard Grossman and Frank Adams in *Taking Care of Business*: "Corporations were abusing their charters to become conglomerates and trusts. They were converting the nation's treasures into private fortunes, creating factory systems and company towns. Political power began flowing to absentee owners intent upon dominating people and nature."<sup>1</sup>

Grossman and Adams note that: "In factory towns, corporations set wages, hours, production processes and machine speeds. They kept blacklists of labor organizers and workers who spoke up for their rights. Corporate officials forced employees to accept humiliating conditions, while the corporations agreed to nothing."

The authors quote Julianna, a Lowell, Massachusetts, factory worker, who wrote: "Incarcerated within the walls of a factory, while as yet mere children, drilled there from five till seven o'clock, year after year...what, we would ask, are we to expect, the same system of labor prevailing, will be the mental and intellectual character of future generations...a race fit only for corporation tools and time-serving slaves?... Shall we not hear the response from every hill and vale: 'Equal rights, or death to the corporations?'"

Industrialists and bankers hired private armies to keep workers in line, bought newspapers and (quoting Grossman and Adams again): "...painted politicians as villains and businessmen as heroes. Bribing state legislators, they then announced legislators were corrupt, that they used too much of the public's resources and time to scrutinise every charter application and corporate operation. Corporate advocates campaigned to replace existing chartering laws with general incorporation laws that set up simple administrative procedures, claiming this would be more efficient. What they really wanted was the end of legislative authority over charters."

During the Civil War, government spending brought corporations unprecedented wealth. "Corporate managers developed the techniques and the ability to organise production on an ever grander scale," according to Grossman and Adams. "Many corporations used their wealth to take advantage of war and Reconstruction years to get the tariff, banking, railroad, labor, and public lands legislation they wanted."

In 1886, the US Supreme Court declared that corporations were henceforth to be considered "persons" under the law, with all of the constitutional rights that designation implies.

The Fourteenth Amendment to the Constitution, passed to give former slaves equal rights, has been invoked approximately ten times more frequently on behalf of corporations than on behalf of African Americans. Likewise the First Amendment, guaranteeing free speech, has been invoked to guarantee corporations the "right" to influence the political process through campaign contributions, which the courts have equated with "speech".

If corporations are "persons", they are persons with qualities and powers that no flesh-and-blood human could ever possess—immortality, the ability to be in many places at once, and (increasingly) the ability to avoid liability. They are also "persons" with no sense of moral responsibility, since their only legal mandate is to produce profits for their investors.

Throughout the late 19th and early 20th centuries, corporations reshaped every aspect of life in America and much of the rest of the world. The factory system turned self-sufficient small farmers into wage-earners and transformed the family from an interdependent economic production unit to a consumption-oriented collection of individuals with separate jobs. Advertising turned productive citizens into "consumers". Business leaders campaigned to create public schools to train children in factory-system obedience to schedules and in the performance of isolated, meaningless tasks. Meanwhile, corporations came to own and dominate sources of information and entertainment, and to control politicians and judges.

During two periods, corporations faced a challenge: the 1890s

(a depression period when Populists demanded regulation of railroad rates, heavy taxation of land held only for speculation, and an increase in the money supply), and the 1930s (when a profound crisis of capitalism led hundreds of thousands of workers and armies of the unemployed to demand government regulation of the economy and to win a 40-hour week, a minimum-wage law, the right to organise, and the outlawing of child labour). But in both cases, corporate capitalism emerged intact.

In the words of historian Howard Zinn: "The rich still controlled the nation's wealth, as well as its laws, courts, police, newspapers, churches, colleges. Enough help had been given to enough people to make Roosevelt a hero to millions, but the same system that had brought depression and crisis...remained."<sup>2</sup>

World War II, like previous wars, brought huge profits to corporations via government contracts. But following this war, military spending was institutionalised, ostensibly to fight the "Cold War". Despite occasional regulatory setbacks, corporations seized ever more power, and increasingly transcended national boundaries, loyalties and sovereignties altogether.

## GLOBAL PILLAGE

In the 1970s, capitalism faced yet another challenge as postwar growth subsided and profits fell. The US was losing its dominant position in world markets; the production of oil from its domestic wells was peaking and beginning to fall, thus making America increasingly dependent upon oil imports from Arab countries; the Vietnam War had weakened the American economy; and Third World countries were demanding a "North-South dialogue" leading towards greater self-reliance for poorer

countries. President Nixon responded by doing away with fixed currency exchange rates and devaluing the dollar, largely erasing US war debts to other countries. Later, newly elected President Reagan, at the 1981 Cancún, Mexico, meeting of 22 heads of state, refused to discuss new financial arrangements with the Third World, thus effectively endorsing their further exploitation by corporations.

Meanwhile, the corporations themselves also responded with a new strategy. Increased capital mobility (made possible by floating exchange rates and new transportation, communication and production technologies) allowed US corporations to move production offshore to "export processing zones" in poorer countries. Corporations also undertook a restructuring process, moving toward "networked production"—in which big firms, while retaining and consolidating power, hired smaller firms to take over aspects of supply, manufacture, accounting and transport. (Economist Bennett Harrison defined networked production as "concentration of control combined with decentralization of production".) This restructuring process is also known as "downsizing", because it results in the shedding of higher-paid employees by large corporations and the hiring of low-wage contingent workers by smaller subcontractors.

Jeremy Brecher and Tim Costello write in *Global Village or Global Pillage* that: "As the economic crisis deepened, there gradually evolved...a 'supra-national policy arena' which included new organizations like the Group of Seven (G7) industrial nations and NAFTA and new roles for established international organisations like EU, IMF, World Bank, and GATT. The

**If corporations are "persons",  
they are persons with  
qualities and powers that  
no flesh-and-blood human  
could ever possess...**

policies adopted by these international institutions allowed corporations to lower their costs in several ways. They reduced consumer, environmental, health, labor, and other standards. They reduced business taxes. They facilitated the move to lower wage areas and threat of such movement. And they encouraged the expansion of markets and the 'economies of scale' provided by larger-scale production."<sup>3</sup>

All of this has led to a globalised economy in which (again quoting Brecher and Costello): "All over the world, people are being pitted against each other to see who will offer global corporations the lowest labor, social, and environmental costs. Their jobs are being moved to places with inferior wages, lower business taxes, and more freedom to pollute. Their employers are using the threat of 'foreign competition' to hold down wages, salaries, taxes, and environmental protections and to replace high-quality jobs with temporary, part-time, insecure, and low-quality jobs. Their government officials are justifying cuts in education, health, and other services as necessary to reduce business taxes in order to keep or attract jobs."

Corporations, no longer bound by national laws, prowl the world looking for the best deals on labour and raw materials. Of the world's top 120 economies, nearly half are corporations, not countries. Thus the power of citizens in any nation to control corporations through whatever democratic processes are available to them is receding quickly.

In November 1999, tens of thousands of students, union members and indigenous peoples gathered in Seattle to protest a meeting of the World Trade Organization (WTO). This mass demonstration seemed to signal the birth of a new global populist uprising against corporate globalisation. In the three years since then, more mass demonstrations—some larger, many smaller—have occurred in Genoa, Melbourne, Milan, Montreal, Philadelphia, Washington and other cities.

In January 2001, George W. Bush and Dick Cheney took office, following a deeply flawed US election. With strong ties to the oil industry and to the huge energy-trading corporation Enron, the new administration quickly proposed a national energy policy that focused on opening federally protected lands for oil exploration and on further subsidising the oil industry.

Enron, George W. Bush's largest campaign contributor, was the seventh largest corporation in the US and the 16th largest in the world. Despite its reported massive profits, it had paid no taxes in four out of the previous five years. The company had thousands of offshore partnerships, through which it had hidden over a billion dollars in debt. When this hidden debt was disclosed in October 2001, the company imploded. Its share price collapsed and its credit rating was slashed. Its executives resigned in disgrace, taking with them multimillion-dollar bonuses, while employees and stockholders shouldered the immense financial loss. Enron's bankruptcy was the largest in corporate history up to that time, but its creative accounting practices appear to be far

from unique, with dozens of other corporations poised for a similar collapse.

Following the outrageous and tragic attacks of September 11, Bush launched a "War on Terror", raising the listed number of potential target countries from three to nearly 50, most having exportable energy resources. With Iraq (holder of the world's second-largest proven petroleum reserves) high on the list of enemy regimes to be violently overthrown, the Bush administration's Terror War appeared to be geared toward making the world safe for the expanded reach of US oil corporations. Meanwhile, new laws and executive orders curtailed constitutional rights and erected screens of secrecy around government actions and decision-making processes.

It remains to be seen how the American populace will react to these new developments. Here again, a little history may help us understand the options available.

### HURDLES IN THE PATH

The Populism of the 1890s failed for two main reasons: divisiveness within, and co-optation from without. While many Populist leaders saw the need for unity among people of different racial and ethnic backgrounds in attacking corporate power, racism was strong among many whites. Most of the Alliance leaders were white farm owners who failed in many instances to support the organising efforts of poor rural blacks, and poor whites as well, thus dividing the movement.

"On top of the serious failures to unite blacks and whites, city workers and country farmers," writes Howard Zinn, "there was the lure of electoral politics... Once allied with the Democratic party in supporting William Jennings Bryan for President in 1896...the pressure for electoral victory led Populism to make deals with the major parties in city after city. If the Democrats won, it would be absorbed. If the Democrats lost, it would disintegrate. Electoral politics brought into the top leadership the political brokers instead of the

agrarian radicals... In the election of 1896, with the Populist movement enticed into the Democratic party, Bryan, the Democratic candidate, was defeated by William McKinley, for whom the corporations and the press mobilised, in the first massive use of money in an election campaign."<sup>4</sup>

Today, a new populist movement could easily fall prey to the same internal divisions and tactical errors that destroyed its counterpart a century ago. In the recent American presidential election, populists faced the choice of supporting their own candidate (Ralph Nader) and thereby contributing to the election of the far-right, pro-corporate Republican candidate (Bush), or supporting the centrist Gore and seeing their movement co-opted by pro-corporate Democrats.

Meanwhile, though African Americans, Asian Americans, Hispanic Americans, European Americans and Native Americans have all been victimised by corporations, class divisions and historical resentments often prevent them from organising to

**Corporations,  
no longer bound by  
national laws,  
prowl the world  
looking for the  
best deals on labour  
and raw materials.**

**Of the world's top  
120 economies, nearly  
half are corporations,  
not countries.**

further their common interests. In recent elections, ultra-right candidate Pat Buchanan appealed simultaneously to "populist" anti-corporate and anti-government sentiments among the working class, as well as to xenophobic white racism. Buchanan's critique of corporate power was shallow, but it was often the only such critique permitted in the corporate-controlled media. One cannot help but wonder: were the corporations looking for a lightning rod to rechannel the anger building against them?

While Buchanan had no chance of winning the presidency, his candidacy did raise the spectre of another kind of solution to the emerging crisis of popular resentment against the system—a solution that again has roots in the history of the past century.

## A FALSE REVOLUTION

In the early 1900s, workers in Italy and Germany built strong unions and won substantial concessions in wages and work conditions; still, after World War I they suffered under a disastrous postwar economy, which fanned unrest. During the early 1920s, heavy industry and big finance were in a state of near-total collapse. Bankers and agribusiness associations offered financial support to Mussolini—who had been a socialist before the war—to seize state power, which he effectively did in 1922 following his march on Rome. Within two years, the Fascist Party (from the Latin *fasces*, meaning a bundle of rods and an axe, symbolising Roman state power) had shut down all opposition newspapers, crushed the socialist, liberal, Catholic, democratic and republican parties (which had together commanded about 80 per cent of the vote), abolished unions, outlawed strikes and privatised farm cooperatives.

In Germany, Hitler led the Nazi Party to power, then cut wages and subsidised industries.

In both countries, corporate profits ballooned. Understandably, given their friendliness to big business, Fascism and Nazism were popular among some prominent American industrialists (such as Henry Ford) and opinion shapers (like William Randolph Hearst).

Fascism and Nazism relied on centrally controlled propaganda campaigns that cleverly co-opted the language of the Left (the Nazis called themselves the National Socialist German Workers Party—while persecuting socialists and curtailing workers' rights). Both movements also made calculated use of emotionally charged symbolism: scapegoating minorities, appealing to mythic images of a glorious national past, building a leader cult, glorifying war and conquest, and preaching that the only proper role of women is as wives and mothers.

As political theorist Michael Parenti points out, historians often overlook Fascism's economic agenda—the partnership between Big Capital and Big Government—in their analysis of its authoritarian social program. Indeed, according to Bertram Gross in his startlingly prescient *Friendly Fascism* (1980), it is possible to achieve fascist goals within an ostensibly democratic society.<sup>5</sup> Corporations themselves, after all, are internally authoritarian (courts have ruled that citizens give up their constitutional rights to free speech, freedom of assembly, etc., when they are at work on corporate-owned property); and as corporations increasingly dominate politics, media and economy, they can mould an entire society to serve the interests of a powerful elite without ever

resorting to stormtroopers and concentration camps. No deliberate conspiracy is necessary, either: each corporation merely acts to further its own economic interests. If the populace shows signs of restlessness, politicians can be hired to appeal to racial resentments and memories of national glory, dividing popular opposition and inspiring loyalty.

In the current situation, "friendly fascism" works somewhat as follows. Corporations drive down wages and pay a dwindling share of taxes (through mechanisms outlined above), gradually impoverishing the middle class and creating unrest. As corporate taxes are cut, politicians (whose election was funded by corporate donors) argue that it is necessary to reduce government services in order to balance the budget. Meanwhile, the same politicians argue for an increase in the repressive functions of government (more prisons, harsher laws, more executions, more military spending). Politicians channel the middle class's rising resentment away from corporations and toward the government (which, after all, is now less helpful and more repressive than it used to be) and against social groups easy to scapegoat (criminals, minorities, teenagers, women, gays, immigrants).

Meanwhile, debate in the media is kept superficial (elections are treated as sporting contests), and right-wing commentators are subsidised while left-of-centre ones are marginalised. People who feel cheated by the system turn to the Right for solace, and vote for politicians who further subsidise corporations, cut government services, expand the repressive power of the state and offer irrelevant scapegoats for social problems with economic roots. The process feeds on itself.

Within this scenario, George W. Bush (and similar ultra-right figures in other countries) are not anomalies but, rather, predictable products of a strategy adopted by economic elites—harbingers of a less-than-friendly

future—as the more "moderate" tactics for the maintenance and consolidation of power founder under the weight of corporate greed and resource exhaustion.

## CAUSE FOR HOPE?

These circumstances are, in their details, unprecedented; but in broad outline we are seeing the re-enactment of a story that goes back at least to the beginning of civilisation. Those with power are always looking for ways to protect and extend it, and to make their power seem legitimate, necessary or invisible so that popular protest seems unnecessary or futile. If protest comes, the powerful always try to deflect anger away from themselves. The leaders of the new populist movement appear to have a good grasp of both the current circumstances and the historical ground from which these circumstances emerge. They seem to have realised that, in order to succeed, the new populism will have to:

- avoid being co-opted by existing political parties;
- heal race, class and gender divisions and actively resist any campaign to scapegoat disempowered social groups;
- avoid being identified with an ideological category—"communist", "socialist" or "anarchist"—against which most of the public is already well inoculated by corporate propaganda;

**Meanwhile, debate in the media is kept superficial (elections are treated as sporting contests), and right-wing commentators are subsidised while left-of-centre ones are marginalised.**

**Continued on page 80**

# ULTRASOUND SCANS NOT SO SAFE AND SOUND

*Ultrasound has been promoted as risk-free and satisfying for prospective parents, but scientific research reveals serious concerns about its safety and usefulness.*

by Dr Sarah J. Buckley © 2002

Brisbane, Australia

Email: sarahjbuckley@uqconnect.net

**W**hen I was pregnant with my first baby in 1990, I decided against having an ultrasound scan. This was a rather unusual decision, as my partner and I are both doctors and had even done pregnancy scans ourselves—rather ineptly, but sometimes usefully—while training in GP obstetrics a few years earlier.

What influenced me the most was my feeling that I would lose something important as a mother if I allowed someone to test my baby. I knew that if a minor or uncertain problem showed up (this is not uncommon), I would be obliged to return again and again, and that after a while it would feel as if my baby belonged to the system and not to me.

In the years since then, I have had three more unscanned babies and have read many articles and research papers about ultrasound. Nothing I have read has made me reconsider my decision.

Although ultrasound may sometimes be useful when specific problems are suspected, my conclusion is that it is at best ineffective and at worst dangerous when used as a "screening tool" for every pregnant woman and her baby.

## ULTRASOUND, PAST AND PRESENT

Ultrasound was developed during World War II to detect enemy submarines, and was subsequently used in the steel industry.

In July 1955, Glasgow surgeon Ian Donald borrowed an industrial machine and, using beefsteaks as controls, began to experiment with abdominal tumours which he had removed from his patients.

He discovered that different tissues gave different patterns of "echo", leading him to realise that ultrasound offered a revolutionary way to look into the previously mysterious world of the growing baby (Wagner, 1995).

This new technology spread rapidly into clinical obstetrics. Commercial machines became available in 1963 (de Crespigny, 1996), and by the late 1970s ultrasound had become a routine part of obstetric care (Oakley, 1986).

Today, ultrasound is seen as safe and effective, and scanning has become a rite of passage for pregnant women in developed countries. Here in Australia, it is estimated that 99% of babies are scanned at least once in pregnancy—mostly as a routine prenatal ultrasound (RPU) at four to five months.

However, there is growing concern as to ultrasound's safety and usefulness. UK consumer activist Beverley Beech has called RPU "the biggest uncontrolled experiment in history" (Beech, 1993), and the Cochrane Collaborative Database—the peak scientific authority in medicine—concludes that "no clear benefit in terms of a substantive outcome measure like perinatal mortality [number of babies dying around the time of birth] can yet be discerned to result from the routine use of ultrasound" (Neilson, 2002).

This seems a very poor reward for the huge costs involved. In 1997–98, for example, A\$39 million was paid by the Australian federal government for pregnancy scans—an enormous expense compared to \$54 million for all other obstetric Medicare costs. This figure does not include the additional costs paid by the woman herself.

The 1999 Australian Senate Committee report, "Rocking the Cradle", recommended that the costs and benefits of routine scanning and current ultrasound practices be formally assessed. Recommendations were also made to develop guidelines for the safe use of all obstetric ultrasound, as well as for the development of standards for the training of ultrasonographers (Senate Community Affairs Reference Committee, 1999). So far, none of these recommendations has been implemented.

## ULTRASOUND TECHNOLOGY AND TECHNIQUES

The term "ultrasound" refers to the ultra high frequency sound-waves used for diagnostic scanning. These waves travel at 10–20 million cycles per second, compared to 10,000–20,000 cycles per second for audible sound (de Crespigny, 1996). Ultrasound waves are emitted by a transducer (the part of the machine that is put onto the body), and a picture of the underlying tissues is built up from the pattern of "echo" waves that return. Hard surfaces such as bone return a stronger echo than soft tissue or fluids, giving the bony skeleton a white appearance on the screen.

Ordinary scans use pulses of ultrasound which last only a fraction of a second, with the interval between waves being used by the machine to interpret the echo that returns. In contrast, Doppler techniques, which are used in specialised scans, foetal monitors and hand-held foetal stethoscopes ("sonicaids"), feature continuous waves, giving much higher levels of exposure than "pulsed" ultrasound. Many women do not realise that the small machines used to listen to their baby's heartbeat are actually using Doppler ultrasound, albeit with low dose parameters.

More recently, ultrasonographers have been using vaginal ultrasound, where the transducer is placed high in the vagina, much closer to the developing baby. This is used mostly in early pregnancy, when abdominal scans can give poor pictures. However, with vaginal ultrasound, there is little intervening tissue to shield the baby, who is at a vulnerable stage of development, and exposure levels will be high. Having a vaginal ultrasound is not a pleasant procedure for the woman; the term "diagnostic rape" was coined to describe how some women experience vaginal scans.

Another recent application for ultrasound is the nuchal translucency test, where the thickness of the skin fold at the back of the baby's head is measured at around three months. A thick nuchal (neck) fold makes the baby more likely, statistically, to have Down's syndrome. When the baby's risk is estimated to be over 1 in 250, a definitive test is recommended. This involves taking some of the baby's tissue by amniocentesis or chorionic villus sampling.

Around 19 out of 20 babies diagnosed as "high risk" by nuchal translucency will not turn out to be affected by Down's syndrome, and their mothers will have experienced several weeks of unnecessary anxiety. A nuchal translucency scan does not detect all babies affected by Down's syndrome.

## INFORMATION GAINED FROM ULTRASOUND

Ultrasound is mainly used for two purposes in pregnancy: either to investigate a possible problem at any stage of pregnancy, or as a routine scan at around 18 weeks.

If there is bleeding in early pregnancy, for example, ultrasound may predict whether miscarriage is inevitable. Later in pregnancy, ultrasound can be used when a baby is not growing or when a breech baby or twins are suspected. In these cases, the information gained from ultrasound can be very useful in decision-making for the woman and her carers. However, the use of routine prenatal ultrasound is more controversial, as this involves scanning (or "screening") all pregnant women in the hope of improving the outcome for some mothers and babies.

The timing of routine scans (at 18 to 20 weeks) is chosen for

pragmatic reasons. It offers a reasonably accurate due date—although dating is most accurate at the early stages of pregnancy when babies vary the least in size—and the baby is big enough for most abnormalities to be seen that are detectable with ultrasound. However, at this stage, the EDD (expected date of delivery) is only accurate to a week either side, and some studies have suggested that an early examination or calculations based on a woman's menstrual cycle can be as accurate as RPU (Olsen, 1997; Kieler, 1993).

And while many women are reassured by a normal scan, RPU actually detects only between 17% and 85% of the 1 in 50 babies who have major abnormalities at birth (Ewigman, 1993; Luck, 1992). A recent study from Brisbane showed that ultrasound at a major women's hospital missed around 40% of abnormalities, with most of these being difficult or impossible to detect (Chan, 1997). Major causes of intellectual disability such as cerebral palsy and Down's syndrome are unlikely to be picked up on a routine scan, as are heart and kidney abnormalities.

When an abnormality is detected, there is a small chance that the finding is a "false positive", where the ultrasound diagnosis is wrong. A UK survey showed that, for 1 in 200 babies aborted for major abnormalities, the diagnosis on post-mortem was less severe than predicted by ultrasound and the termination was probably unjustified. In this survey, 2.4% of the babies diagnosed

with major malformations, but not aborted, had conditions that were significantly over- or under-diagnosed (Brand, 1994).

There are also many cases of error with more minor abnormalities, which can cause anxiety and lead to repeated scans, and there are some conditions which have been seen to resolve spontaneously (see, for example, Saari-Kemppainen, 1990).

As well as false positives, there are also uncertain cases where the ultrasound findings cannot be easily interpreted and the outcome for the baby is

not known. In one study involving women at high risk, almost 10% of scans were uncertain (Sparling, 1988). This can create immense anxiety for the woman and her family, and the worry may not be allayed by the birth of a normal baby. In the same study, mothers with "questionable" diagnoses still had this anxiety three months after the birth of their baby.

In some cases of uncertainty, the doubt can be resolved by further tests such as amniocentesis. In this situation, there may be up to two weeks' wait for results, during which time a mother has to decide if she will terminate the pregnancy if an abnormality is found. Even mothers who receive reassuring news have felt that this process has interfered with their relationship with their baby (Brookes, 1994-95).

As well as estimating the EDD and checking for major abnormalities, RPU can also identify a low-lying placenta (placenta praevia) and detect the presence of more than one baby at an early stage of pregnancy. However, 19 out of 20 women who have placenta praevia detected on an early scan will be needlessly worried: the placenta will effectively move up and not cause problems at the birth. Furthermore, detection of placenta praevia by RPU has not been found to be safer than detection in labour (Saari-Kemppainen, 1990).

No improvement in outcome has been shown for multiple pregnancies, either; the vast majority of these will be detected before

**When an abnormality is detected, there is a small chance that the finding is a "false positive", where the ultrasound diagnosis is wrong.**

labour, even without routine prenatal ultrasound (MIDIRS, 1995).

The American College of Obstetricians, in their guidelines on routine ultrasound in low-risk pregnancy, conclude that: "In a population of women with low-risk pregnancies, neither a reduction in perinatal morbidity [harm to babies around the time of birth] and mortality nor a lower rate of unnecessary interventions can be expected from routine diagnostic ultrasound. Thus ultrasound should be performed for specific indications in low-risk pregnancy" (ACOG, 1997).

## BIOLOGICAL EFFECTS OF ULTRASOUND

Ultrasound waves are known to affect tissues in two main ways. Firstly, the sonar beam causes heating of the highlighted area by about 1° Celsius. This is presumed to be non-significant, based on whole-body heating in pregnancy, which seems to be safe up to 2.5°C (American Institute of Ultrasound Medicine Bioeffects Report, 1988).

The second recognised effect is cavitation, where the small pockets of gas which exist within mammalian tissue vibrate and then collapse. In this situation: "...temperatures of many thousands of degrees Celsius in the gas create a wide range of chemical products, some of which are potentially toxic. These violent processes may be produced by micro-second pulses of the kind which are used in medical diagnosis..." (*American Inst. of Ultrasound Medicine Bioeffects Report*, 1988). The significance of cavitation effects in human tissue is unknown.

A number of studies have suggested that these effects are of real concern in living tissues. The first study suggesting problems was a study on cells grown in the lab. Cell abnormalities caused by exposure to ultrasound were seen to persist for several generations (Liebeskind, 1979). Another study showed that, in newborn rats (who are at a similar stage of brain development to humans at four to five months *in utero*), ultrasound can damage the myelin that covers nerves (Ellisman et al., 1987), indicating that the nervous system may be particularly susceptible to damage from this technology.

A 1999 animal study by Brennan and colleagues, reported in *New Scientist* (12 June 1999), showed that exposing mice to dosages typical of obstetric ultrasound caused a 22% reduction in the rate of cell division and a doubling of the rate of apoptosis, or programmed cell death, in the cells of the small intestine.

Mole (1986) comments: "If exposure to ultrasound...causes death of cells, then the practice of ultrasonic imaging at 16 to 18 weeks will cause loss of neurones [brain cells] with little prospect of replacement of lost cells... The vulnerability is not for malformation but for maldevelopment, leading to mental impairment caused by overall reduction in the number of functioning neurones in the future cerebral hemispheres."

Studies on humans exposed to ultrasound have shown that possible adverse effects include premature ovulation (Testart, 1982), preterm labour or miscarriage (Lorenz, 1990; Saari-Kemppainen, 1990), low birth weight (Newnham, 1993; Geerts, 1996), poorer condition at birth (Thacker, 1985; Newnham, 1991), perinatal death (Davies, 1992), dyslexia (Stark, 1984), delayed speech development (Campbell, 1993), and less right-handedness (Salvesen, 1993; Kieler, 1998a; Salvesen, 1999). Non-right-handedness is, in other circumstances, seen as a marker of damage to the developing brain (Odent, 1998). One Australian

study showed that babies exposed to five or more Doppler ultrasounds were 30% more likely to develop intra-uterine growth retardation (IUGR)—a condition that ultrasound is often used to detect (Newnham, 1993).

Two long-term randomised controlled trials, comparing exposed and unexposed children's development at eight to nine years old, found no measurable effect from ultrasound (Salvesen, 1992; Kieler, 1998b). However, as the authors note, intensities used today are many times higher than in 1979 to 1981. Further, in the major branch of one trial, scanning time was only three minutes (Salvesen, 1993). More studies are obviously needed in this field, particularly in the areas of Doppler and vaginal ultrasound where exposure levels are much higher.

A further problem with studying ultrasound's effects is the huge range of output, or dose, possible from a single machine. Modern machines can give comparable ultrasound pictures using a lower or a 5,000 times higher dose (Meire, 1987), and there are no standards to ensure that the lowest dose is used. Because of the complexity of machines, it is difficult even to quantify the dose given in each examination (Taylor, 1990). In Australia, training is voluntary, even for obstetricians, and the skill and experience of operators varies widely.

A summary of the safety of ultrasound in human studies, published in May 2002 in the prestigious US journal *Epidemiology*, concluded: "...there may be a relation between prenatal ultrasound exposure and adverse outcome. Some of the reported effects include growth restriction, delayed

speech, dyslexia, and non-right-handedness associated with ultrasound exposure. Continued research is needed to evaluate the potential adverse effects of ultrasound exposure during pregnancy. These studies should measure the acoustic output, exposure time, number of exposures per subject, and the timing during the pregnancy when exposure(s) occurred" (Marinac-Dabic, 2002).

The UK consumer organisation AIMS (Association for Improvements in the Maternity Services) has produced a booklet, "Ultrasound Unsound?", originally published in 1993 and recently updated. This very comprehensive publication, which I highly recommend, includes a form that pregnant women undergoing ultrasound can ask their carers to fill out. You can make your own form based on the information as below, or obtain the booklet at website <http://www.birthinternational.com.au>.

## WOMEN'S EXPERIENCES WITH ULTRASOUND

Women have not been consulted at any stage in the development of this technology, and their experiences and wishes are presumed to coincide with, or be less important than, the medical information that ultrasound provides. For example, supporters of RPU presume that early diagnosis and/or termination is beneficial to the affected woman and her family.

However, the discovery of a major abnormality on RPU can lead to very difficult decision-making. Some women who agree to have an ultrasound are unaware that they may get information about their baby that they do not want, as they would not contemplate a termination. Other women can feel pressured to have a termination, or at the least feel some emotional distancing from their "abnormal" baby (Brookes, 1994–95).

Furthermore, there is no evidence that women who have chosen termination are, in the long term, psychologically better off than

**A further problem with studying ultrasound's effects is the huge range of output, or dose, possible from a single machine.**

## My Baby's Ultrasound Exposure Record

The following procedure requires the use of ultrasound .....

This is necessary to obtain the following information .....

To my knowledge, there is no current alternative method available to obtain this information that carries less risk to .....

(mother's name)

Signature (doctor or midwife)..... Date .....

### The ultrasonographer is asked to specify:

Manufacturer and model of ultrasound equipment .....

Date of last calibration .....

Type or combination of types of ultrasound used .....

Intensity of exposure (w/cm sq or mW/cm sq) .....

Time commenced ..... Time completed .....

Duration of exposure .....

Name of hospital or clinic .....

Carried out by .....

Qualifications ..... Position.....

Signature ..... Date.....

## CONCLUSIONS AND RECOMMENDATIONS

I would urge all pregnant women to think deeply before they choose to have a routine ultrasound. It is not compulsory, despite what some doctors have said, and the risks, benefits and implications of scanning need to be considered for each mother and baby according to their specific situation.

If you choose to have a scan, be clear about the information that you do and do not want to be told. Have your scan done by an operator with a high level of skill and experience (usually this means someone who performs at least 750 scans per year) and say that you want the shortest scan possible. Ask them to fill out the form or give you the information, as above, and to sign it.

If an abnormality is found, ask for counselling and a second opinion as soon as practical. And remember that it's *your* baby, *your* body and *your* choice.

### References

- American College of Obstetricians and Gynecologists (ACOG). Routine Ultrasound in Low-Risk Pregnancy. In: *ACOG Practice Patterns – Evidence-Based Guidelines for Clinical Issues in Obstetrics and Gynecology*, no. 5, August 1997.
- Association for Improvements in the Maternity Services (AIMS), UK. Ultrasound Unsound? *AIMS Journal*, vol. 5, no. 1, spring 1993. The updated version is available at <http://www.birthinternational.com.au>.
- American Institute of Ultrasound Medicine Bioeffects Report 1988. *Journal of Ultrasound Medicine*,

women whose babies have died at birth; in fact, there are suggestions that the opposite may be true in some cases (Watkins, 1989).

And when termination has been chosen, women are unlikely to share their story with others and can experience considerable guilt and pain from the knowledge that they themselves chose the loss (MIDIRS, 1996).

When minor abnormalities are found—which may or may not be present at birth, as discussed above—women can feel that some of the pleasure has been taken away from their pregnancy.

Women's experiences with ultrasound and other tests used for prenatal diagnosis (e.g., amniocentesis) are thoughtfully presented by Barbara Katz Rothman in her book, *The Tentative Pregnancy*. The author documents the heartache that women can go through when a difficult diagnosis is made; this pain can take years for some women to resolve. She suggests that the large numbers of screening tests currently being offered to check for abnormalities may make every woman feel that her pregnancy is "tentative" until she receives reassuring results.

To my mind, ultrasound also represents yet another way in which the deep internal knowledge that a mother has of her body and her baby is made secondary to technological information that comes from an "expert" using a machine. Thus the "cult of the expert" is imprinted from the earliest weeks of life.

Furthermore, by treating the baby as a separate being, ultrasound artificially splits mother from baby well before this is a physiological or psychic reality. This further emphasises our culture's favouring of individualism over mutuality and sets the scene for possible—but, to my mind, artificial—conflicts of interest between mother and baby in pregnancy, birth and parenting.

September 1988, 7:S1-S38.

- Beech BL. Ultrasound – Unsound? Talk at Mercy Hospital, Melbourne, April 1993.
- Brand IR, Kaminopetros P, Cave M et al. Specificity of antenatal ultrasound in the Yorkshire region: a prospective study of 2261 ultrasound-detected anomalies. *Br. J. Obstet. Gynaecol.* 1994, vol. 101, no. 5, pp. 392-397.
- Brookes A. Women's experience of routine prenatal ultrasound. *Healthsharing Women*, the newsletter of Healthsharing Women's Health Resource Service, vol. 5, nos 3 & 4, December 1994–March 1995.
- Campbell JD et al. Case-control study of prenatal ultrasonography in children with delayed speech. *Can. Med. Ass. J.* 1993, vol. 149, no. 10, pp. 1435-1440.
- Chan FY. Limitations of Ultrasound. Paper presented at Perinatal Society of Australia and New Zealand 1st Annual Congress, Fremantle, 1997.
- Davies J et al. Randomised controlled trial of Doppler ultrasound screening of placental perfusion in pregnancy. *Lancet* 1992;340:1299-1303.
- de Crespigny L, Dredge R. *Which Tests For My Unborn Baby?* Oxford University Press, Melbourne, 1996, revised edition.
- Ellisman MH, Palmer DE, Andre MP. Diagnostic levels of ultrasound may disrupt myelination. *Experimental Neurology* 1987, vol. 98, no. 1, pp. 78-92.
- Ewigman BG, Crane JP, Frigoletto FD et al. Effect of prenatal ultrasound screening on perinatal outcome. RADIUS study group. *New England J. Med.* 1993, vol. 329, no. 12, pp. 821-7.
- Geerts JGM, Brand E, Theron B. Routine obstetric ultrasound in South Africa: cost and effect on perinatal outcome – a prospective randomised controlled trial. *Br. J. Obstet. Gynaecol.* 1996, vol. 103, pp. 501-507.
- Kieler H, Axelsson O, Nilsson S, Waldenström U. Comparison of ultrasonic measurement of biparietal diameter and last menstrual period as a predictor of day of delivery in women with regular 28-day cycles. *Acta-Obstet.-Gynecol.-Scand.* 1993, vol. 75, no. 5, pp. 347-9.
- Kieler H, Axelsson O, Haguland B et al. Routine ultrasound screening in pregnancy and the children's subsequent handedness. *Early Human Dev.* 1998, vol. 50, no. 2, pp. 233-245.

**Continued on page 82**

# THE UN IPCC'S ARTFUL BIAS ON CLIMATE CHANGE

***United Nations  
IPCC scientists  
blame human  
interference, not  
natural variation,  
for causing our  
changing climate,  
and manipulate the  
data to suit their  
arguments.***

**by David E. Wojick, PhD © 2002**

President  
Climatechangedebate.org  
USA

Email:  
dwojick@climatechangedebate.org  
Website:  
<http://www.climatechangedebate.org>

## **Glaring Omissions, False Confidence and Misleading Statistics**

**T**he United Nations Intergovernmental Panel on Climate Change (UN IPCC) Working Group I (WGI) Summary for Policymakers (SPM) of the Third Assessment Report (TAR) (titled *Climate Change 2001: The Scientific Basis*) is not an assessment of climate change science, even though it claims to be. Rather, it is an artfully constructed presentation of just the science that supports the fear of human-induced climate change. It is as one sided as a legal brief, which it resembles.

Line-by-line analysis of the SPM reveals that all of the science that cuts against the Theory of Human Interference with Climate has been systematically omitted. In some cases, the leading arguments against human interference are actually touched on, but without being revealed or discussed. In other cases, the evidence against human interference is simply ignored. Because of these strategic omissions, the SPM voices a degree of certainty that is entirely false.

Glaring omissions are only glaring to experts, so the "policymakers" as well as the press and the public who read the SPM will not realise they are being told only one side of the story. But the scientists who drafted the SPM know the truth, as revealed by the sometimes artful way they conceal it.

This deliberate distortion can only be explained by the fact that the UN IPCC is part of an advocacy process, organised by the United Nations Environment Program and supporting the Kyoto Protocol.

What is systematically omitted from the SPM are precisely the uncertainties and positive counter-evidence that might negate the human interference theory. Instead of assessing these objections, the Summary confidently asserts just those findings that support its case. In short, this is advocacy, not assessment.

This study grows out of several years of research into the logic of the climate change debate. During that time, I have operated an email listserv where knowledgeable people from all sides of the climate change issue have posted over 25,000 messages. From this experience, I have gained a comprehensive understanding of just how complex and unsettled the science really is. I have become increasingly distressed by statements made by supporters of the Kyoto Protocol to the effect that the science is settled, or that the uncertainties have diminished to the point where action is obviously justified. Nothing could be further from the truth.

Carbon dioxide is not pollution. On the contrary, atmospheric CO<sub>2</sub> is the Earth's entire food supply, and 95% of the emissions are natural. We could not live without them, for watching a child grow is watching processed carbon dioxide being reprocessed. Failure to mention this fundamental fact is the most astounding omission in the SPM. However, since the issue at hand is climate change, not food, I will not go further into this side of the CO<sub>2</sub> equation, vital though it be.

I am particularly concerned that the Intergovernmental Panel on Climate Change is being represented as a neutral body. Such claims are simply false, and it is the purpose of this study to demonstrate that they *are* false.

Because the IPCC scientific Summary for Policymakers is completely one sided, most of its deceptions are omissions. One cannot simply point to omissions as one can to falsehoods, so I have undertaken to catalogue the omissions and the false assertions of confidence that they enable, on a line-by-line basis. This present report is just a start, and more cases will be forthcoming over time. But time is of the essence, and this small collection

is sufficient to make the point. (An earlier draft of this report can be found at the website [http://www.john-daly.com/guests/un\\_ipcc.htm](http://www.john-daly.com/guests/un_ipcc.htm).)

The IPCC Summary for Policymakers is a study in artful bias. Specific examples of glaring omissions, false confidence and misleading statistics in the Summary are covered in the following pages (my emphasis is added in bold italics). (The UN IPCC WGI Summary for Policymakers as well as the Technical Summary of the report, *Climate Change 2001: The Scientific Basis*, is available at the IPCC's website, <http://www.ipcc.ch/>.)

### Temperature Record Error

Do we know that the Earth is actually warming? The problem of errors in the surface temperature record is profound. Likely sources of bias in the surface temperature record of the last 140 years, which are well known and considerable, are ignored. The amount of warming is claimed to be known with a false degree of confidence. We do not, in fact, know that the Earth has warmed at all.

The discussion on SPM page 2 (the first page of text) begins with this headline: "The global average surface temperature *has increased* over the 20th century by about 0.6°C"—not "may have", or even "is likely to have", but simply "has". This is false certainty. Any suggestion of doubt is omitted, but there is plenty to doubt.

The text itself says: "The global average surface temperature (the average of near surface air temperature over land, and sea surface temperature) has increased since 1861. Over the 20th century the increase has been 0.6 ±0.2°C (figure 1a). This value is about 0.15°C larger than that estimated by the SAR [Second Assessment Report] for the period up to 1994, owing to the relatively high temperatures of the additional years (1995 to 2000)

**The amount of warming is claimed to be known with a false degree of confidence. We do not, in fact, know that the Earth has warmed at all.**

and improved methods of processing the data. These numbers *take into account various adjustments, including urban heat island effects.*"

This is the only reference in the text to any possible problems with the temperature record. It says "These numbers take into account various adjustments", with special reference to urban heat island effects. False certainty. The discussion of these problems—how likely they are to be significant, and how they have been taken into account—has simply been omitted. In fact, how well they have been taken into account is highly contentious.

The legend for figure 1a at least has more detail, albeit in finer print. It says this: "The Earth's surface temperature is shown year by year (red bars [in the original report, grey in this version]) and approximately decade by decade (black line, a filtered annual curve suppressing fluctuations below near decadal time-scales). *There are uncertainties in the annual data (thin black whisker bars represent the 95% confidence range) due to data gaps, random instrumental errors and uncertainties, uncertainties in bias corrections in the ocean surface temperature data and also in adjustments for urbanisation over the land.*

Over both the last 140 years and 100 years, the best estimate is that the global average surface temperature has increased by 0.6 ±0.2°C."

This at least mentions specific problems. But notice the placement of the parenthetical expression in the pivotal second sentence, just before the list. This seems to say quite clearly that the error bars give the 95% confidence level for the uncertainties listed. This is simply false. The error bars give at best the 95% confidence level for the pure error of sampling, which assumes the sample is random and there are no measurement errors of the sort

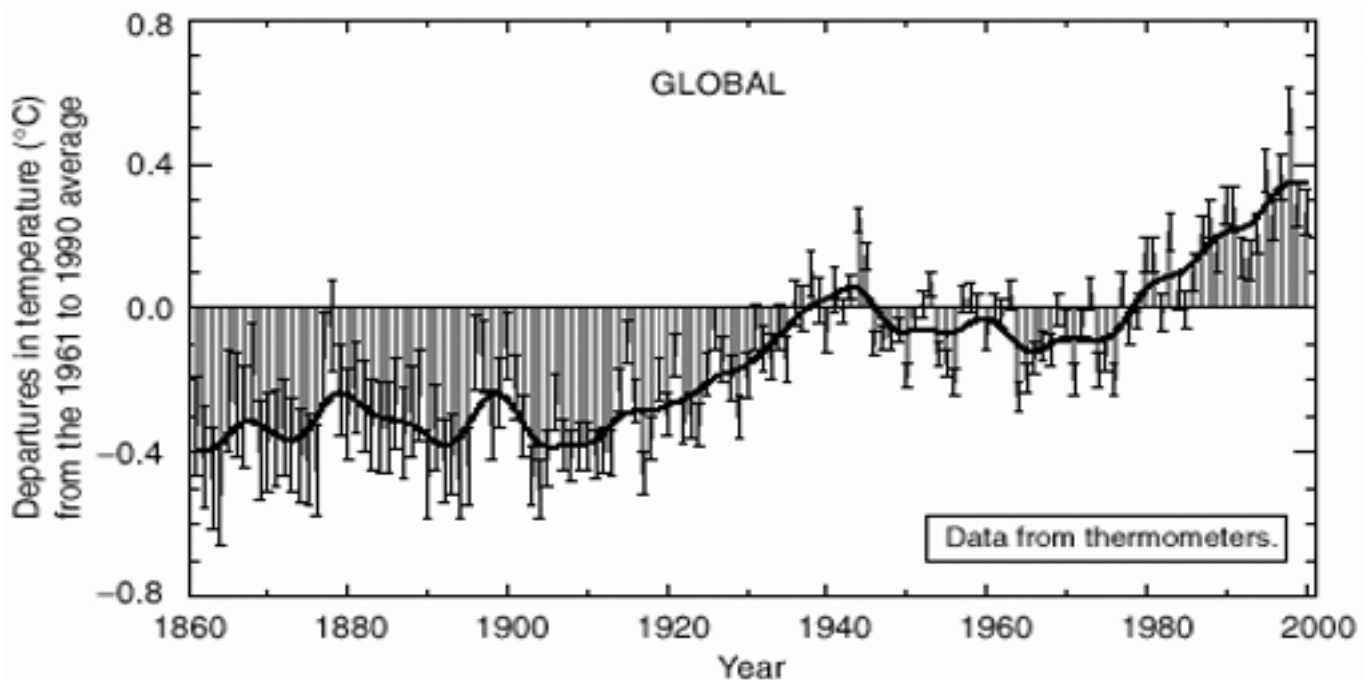

SPM Figure 1a: Variations of the Earth's surface temperature for the past 140 years

listed in the very sentence being modified. This comes as close to outright lying as anything we have found so far.

The truth is, there is no way to correct for most measurement errors, including the urban heat island effect. The magnitude of these errors, which may be quite large, is simply unknown. The supposed corrections that have been made to date are guesswork.

Nor does there seem to be any reference to the fact that this is a "convenience sample", not a random sample of the Earth's surface, as required by sampling science, unless it is the innocent-sounding term, "data gaps". Reference to data gaps suggests that sometimes a station did not record, or that the data is bad—not that there is, in actuality, no data for most of the Earth, most of the time. So the fact that we merely have a convenience sample is either omitted or cleverly disguised.

Statistical theory is perfectly clear that a random sample is required in order to estimate confidence levels. But the "sample" in question is just those stations that happened to measure temperatures in the last 140 years. No random sample of the Earth's surface would look like this set of stations, which provide virtually no data for most of the Earth's surface—the oceans, poles or tropics—for most of the period.

The sample the UN IPCC is using is called in statistics a convenience sample; that is, data is taken where it is most convenient. Convenience samples provide some information about the population being sampled; in this case, the temperature everywhere on Earth for 140 years. But statistical theory is adamant that you cannot legitimately infer the mean of the population or assign any confidence level from a convenience sample. Thus the UN IPCC's statistics regarding temperature are completely misleading.

While beyond the scope of this particular issue, it should be noted that the 1,000-year temperature record shown in figure 1b involves the same misleading statistics. However, the case is much worse because, in the 1,000-year record, temperature is not even measured.

Moreover, the number of items in the convenience sample is tiny. It is preposterous to claim to know the temperature of the entire Earth from such a sample. We simply do not know if the entire Earth has warmed or not. The most we know is what has happened in certain places and times, and likely measurement error makes even this information highly uncertain.

### Satellite versus Surface Temperatures

The satellite temperature record contradicts the surface record. This is a deep dilemma for climate change science. The gaping inconsistency between the recent warming shown in the surface temperature record and the absence of warming in the satellite record is simply shrugged off.

The UN IPCC WGI SPM page 4 begins with this section headline: "**Temperatures have risen** during the past four decades in the lowest 8 kilometres of the atmosphere." As explained below, this statement is highly misleading. The section itself consists of these three rather convoluted paragraphs:

"Since the late 1950s (the period of adequate observations from weather balloons), the overall global temperature increases in the lowest 8 kilometres of the atmosphere and in surface temperature **have been similar** at 0.1°C per decade.

"Since the start of the satellite record in 1979, both satellite and weather balloon measurements show that the global average temperature of the lowest 8 kilometres of the atmosphere has changed

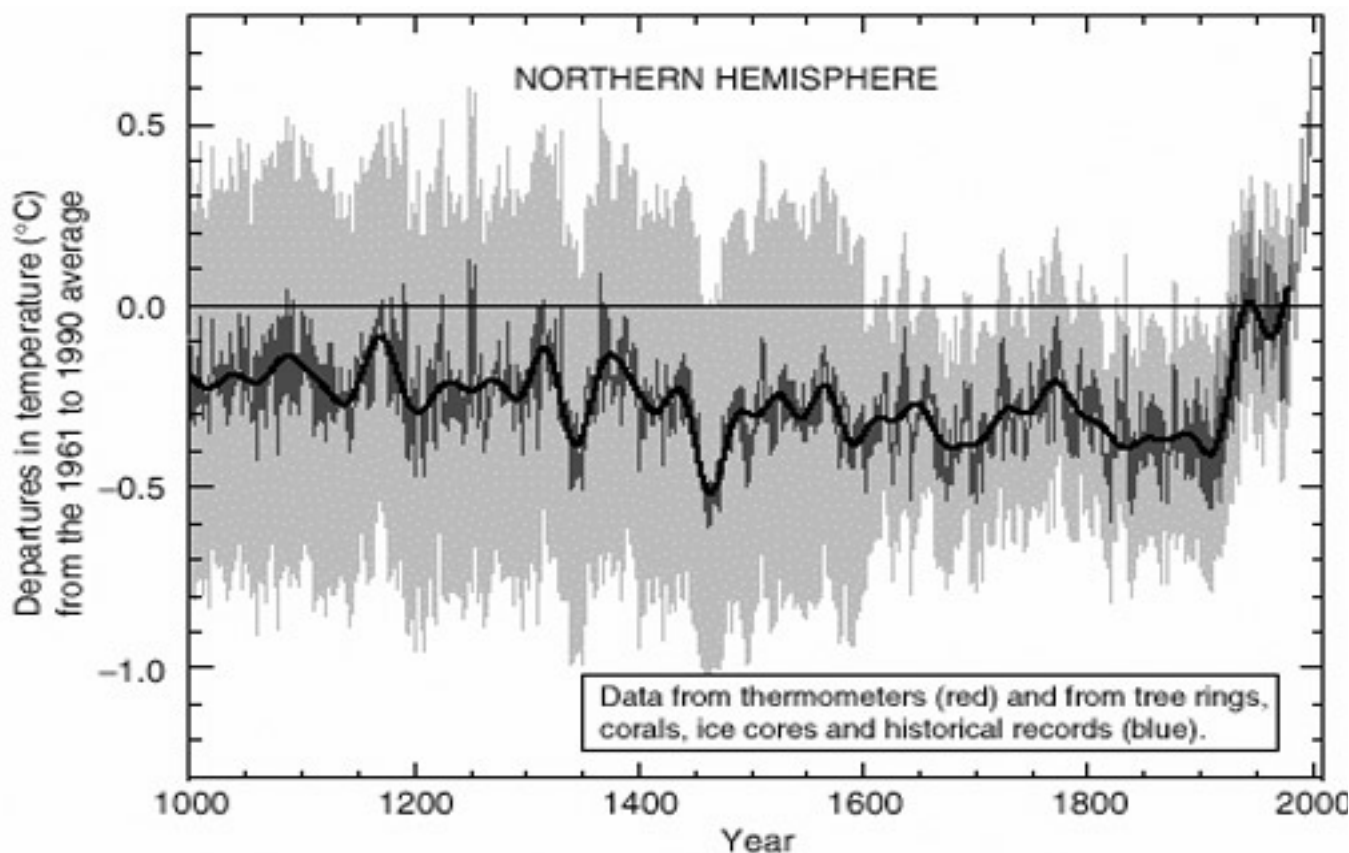

SPM Figure 1b: Variations of the Earth's surface temperature for the past 1,000 years

by  $+0.05 \pm 0.10^\circ\text{C}$  per decade, but the global average surface temperature has increased significantly by  $+0.15 \pm 0.05^\circ\text{C}$  per decade. **The difference in the warming rates is statistically significant.** This difference occurs primarily over the tropical and sub-tropical regions.

"The lowest 8 kilometres of the atmosphere and the surface are influenced differently by factors such as stratospheric ozone depletion, atmospheric aerosols and the El Niño phenomenon. Hence, it is physically plausible to expect that over a short time period (e.g., 20 years) there may be differences in temperature trends. In addition, spatial sampling techniques can also explain some of the differences in trends, but **these differences are not fully resolved.**"

These three paragraphs mask a profound contradiction in climate change science, a contradiction that should be highlighted and discussed but is merely glossed over—namely, that *the satellite temperature record contradicts the surface record.*

What the section headline does not say is that virtually all of the atmospheric warming is in the balloon record of the first two decades of the four-decade period—the 1960s and 1970s—when the surface record shows only a little warming. Then the surface record shows rapid warming for two decades while the (then new) satellite record shows virtually no warming at all, except for the 1998 El Niño.

Thus, while the statement in the first paragraph that the trends are "similar" is statistically correct, it ignores the fact that the changes occur at completely different times. The last two paragraphs state correctly that these are significant differences that are not fully resolved, but any discussion of what it means is simply omitted.

What is omitted is the fact that climate science cannot explain this contradiction. Greenhouse gases have to warm the

atmosphere, where the heat is trapped, before warming the surface of the Earth below. If this science is correct, then one of the temperature records must be incorrect, most likely the surface record that shows the warming, because of known errors. But if there has been no warming in the last two decades, then many of the IPCC's claims which depend on such warming are simply false. Likewise, prior warming shown in the surface temperature record may be false.

Even worse, if both temperature records are correct, then our understanding of the greenhouse effect is incorrect. This is a huge dilemma for the science, and there is a great deal of speculation about it, some of which is alluded to in the third paragraph quoted.

It should be noted that there is a widespread misconception that a National Academy of Sciences panel resolved this issue in January 2000. In fact, the panel concluded just what I have said above: that we do not understand how this contradiction can arise, if both temperature records are correct. Simply to gloss over this deep scientific uncertainty is a major omission indeed—perhaps the greatest omission in the UN IPCC SPM.

### Uncertainty due to Aerosols

The IPCC has suppressed the far-reaching significance of aerosol forcing, not only in the WGI SPM text but in the modeling as well. The enormous—and growing—uncertainty as to the effect of aerosols on climate is masked in the discussion and is deliberately suppressed in predicting the future. If included, the UN IPCC's 100-year prediction would embrace the possibility of *no warming*, or even *cooling*.

Discussion of aerosols in the UN IPCC WGI SPM begins on page 5 with this headline: "Emissions of greenhouse gases and

## The global mean radiative forcing of the climate system for the year 2000, relative to 1750

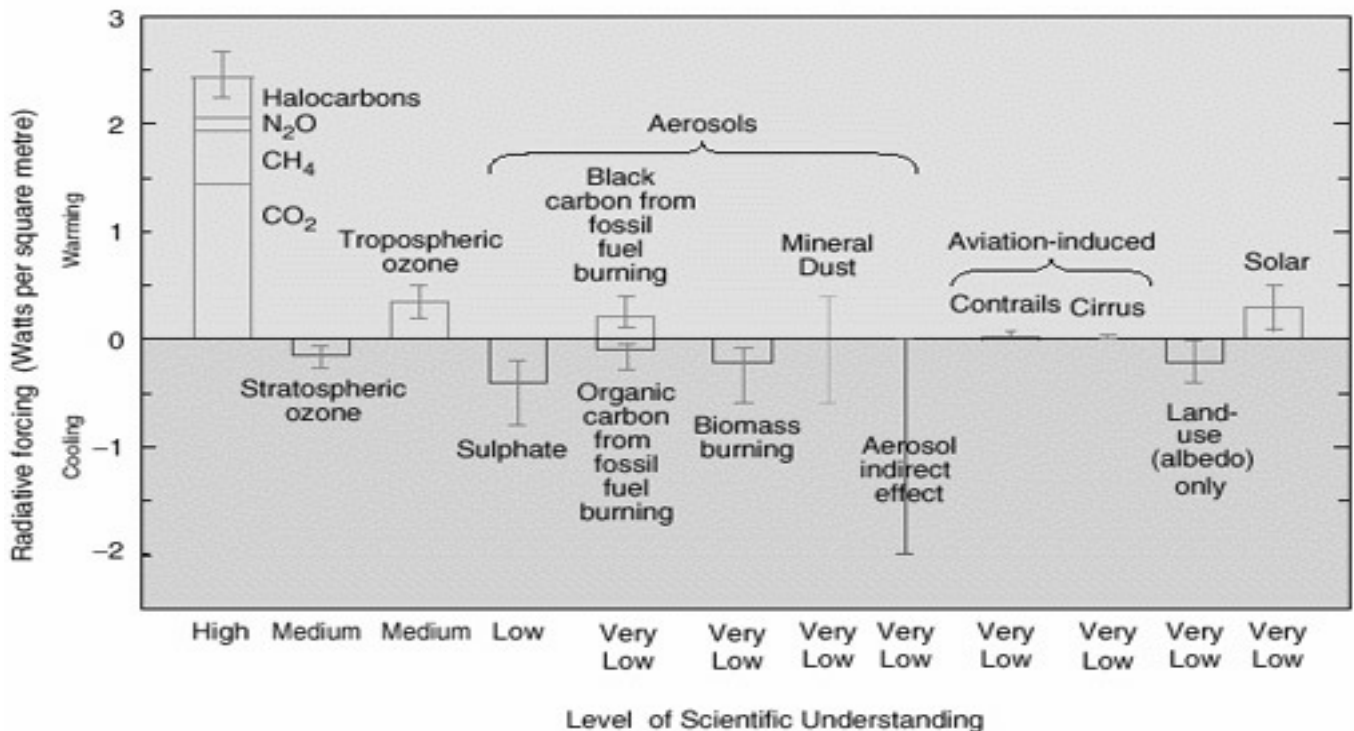

SPM Figure 3: SPM presentation of forcings

aerosols due to human activities continue to alter the atmosphere in ways that are *expected to affect the climate*." This statement reflects a false certainty. Whether or not human emissions will affect climate is obviously a matter of great debate. What follows, however, are some incredible omissions.

The role of aerosols is explained as follows: "A negative radiative forcing, which can arise from an increase in some types of aerosols (microscopic airborne particles), tends to cool the surface... *Characterisation of these climate forcing agents and their changes over time...is required* to understand past climate changes in the context of natural variations and *to project what climate changes could lie ahead*. Figure 3 shows current estimates of the radiative forcing due to increased concentrations of atmospheric constituents and other mechanisms."

This text states quite clearly and correctly that an ability to predict future climate (if that is even possible) requires an understanding of the effect of aerosols. The last sentence says that "current estimates of the radiative forcing" of aerosols are shown in figure 3. This sentence is false. In fact, not only are the estimated uncertainties in aerosol forcings not shown, they are also excluded from the projections of future climate. These are major omissions.

Figure 3 shows estimated forcings for five classes of aerosols. For four of these classes there is also a vertical error bar which the legend explains "indicates a range of estimates, guided by the spread in the published values of the forcings and physical understanding". In addition, each class is labelled with a "Level of Scientific Understanding". One class is labelled "low" and the other four are labelled "very low". No explanation of these uncertainty levels is provided. However, in the UN IPCC's 1995 Second Assessment Report, an earlier version of this same figure appears as figure 2.16 on page 117. Here it is explained that the levels "low" and "very low" are "*our subjective confidence that the actual forcing lies within this error bar*". In fact, the levels are headed "Level of Confidence", not "Level of Scientific Understanding".

In plain language, this means that the chances that the aerosol forcings actually lie within the error bars are very low in most cases. Conversely, it is very likely that the actual forcings lie outside these error bars. What, then, is the likely range for these forcings? We are not told. In fact, the very issue, which was at least alluded to in the IPCC SAR, has now been entirely omitted.

The truth is that the possible range of forcings is very large, much larger than the error bars show. Therefore, the range of aerosol forcings is much larger than the ranges for the greenhouse gases, which are shown to have a "high" level of scientific understanding. If the correct error bars for aerosols were shown—bars that display the likely range of forcings—they would be seen to overwhelm the greenhouse gas forcings.

In short, we simply do not understand aerosol forcing. In fact, a recent paper in the journal *Science* claims that the range of possible forcings is as much as twice the very large range that is not shown in the TAR. This indicates that our understanding of aerosol forcing is diminishing as research proceeds. (See

"Reshaping the Theory of Cloud Formation" by R. J. Charlson et al., *Science*, June 15, 2001.)

If, as the UN IPCC states quite clearly and correctly, an ability to project future climate requires an understanding of the effect of aerosols, then we simply do not have that ability. Yet the IPCC does project future climates, based on various scenarios.

How does the UN IPCC deal with our profound lack of understanding of aerosol forcings? The answer lies in an incredible footnote on page 13, specifically footnote 11. In the preceding text, the IPCC says this: "The globally averaged surface temperature is projected to increase by 1.4 to 5.8°C...over the period 1990 to 2100. These results are for the full range of 35 SRES scenarios, based on a number of climate models." Footnote 11 amends this 1.4 to 5.8°C projection as follows: "*This range does not include uncertainties in the modelling of radiative forcing, e.g., aerosol forcing uncertainties.*"

So the UN IPCC has simply ignored the very large aerosol uncertainties. No reason is given—but if these uncertainties were included, some of the scenarios would yield projections of future *cooling*, not warming. Perhaps the UN IPCC does not want to admit the possibility that there may be no warming at all, or actual cooling.

In any case, it is clear that the entire issue of aerosol uncertainty has been omitted from the WGI SPM, and the language of the key figure has been changed. Far worse, however, is that the effect of this uncertainty has been deliberately suppressed in the model projections of future climate. It is hard not to see this as scientific fraud.

#### Natural GHG Emissions

Human greenhouse gas (GHG) emissions are a tiny fraction of natural emissions. The fact that the vast majority of all greenhouse gas emissions are natural is ignored.

The discussion of GHG emissions on UN IPCC WGI SPM page 7 contains these three sequential paragraphs:

"The rate of increase of atmospheric CO<sub>2</sub> concentration has been about 1.5 ppm (0.4%) per year over the past two decades. During the 1990s the year-to-year increase varied from 0.9 ppm (0.2%) to 2.8 ppm (0.8%). A large part of this variability is due to the effect of climate variability (e.g., El Niño events) on CO<sub>2</sub> uptake and release by land and oceans.

"The atmospheric concentration of methane (CH<sub>4</sub>) has increased by 1060 ppb (151%) since 1750 and continues to increase. The present CH<sub>4</sub> concentration has not been exceeded during the past 420,000 years. The annual growth in CH<sub>4</sub> concentration slowed and became more variable in the 1990s, compared with the 1980s. *Slightly more than half of current CH<sub>4</sub> emissions are anthropogenic* (e.g., use of fossil fuels, cattle, rice agriculture and landfills). In addition, carbon monoxide (CO) emissions have recently been identified as a cause of increasing CH<sub>4</sub> concentration.

"The atmospheric concentration of nitrous oxide (N<sub>2</sub>O) has increased by 46 ppb (17%) since 1750 and continues to increase. The present N<sub>2</sub>O concentration has not been exceeded during at least the past thousand years. *About a third of current N<sub>2</sub>O*

**Human greenhouse gas (GHG) emissions are a tiny fraction of natural emissions.**

**The fact that the vast majority of all greenhouse gas emissions are natural is ignored.**

**emissions are anthropogenic** (e.g., agricultural soils, cattle feed lots and chemical industry)."

This parallel construction requires that there be a sentence explaining the fraction of CO<sub>2</sub> emissions that are anthropogenic, but there is none. It would read as follows: "About one twenty-fifth of current CO<sub>2</sub> emissions are anthropogenic." The important fact that the vast majority of CO<sub>2</sub> emissions are natural has been omitted.

In addition, not even mentioned is water vapour, by far the most important greenhouse gas. Natural emissions of water vapour are so enormous that human emissions do not even measure in comparison. If this were explained, there would also be a sentence saying: "Virtually no water vapour emissions are anthropogenic."

### Chaos in the Climate System

The UN IPCC has ignored major scientific advances that undercut the theory of human interference, including the complex chaos science that is presented in the Third Assessment Report itself. According to the TAR, the climate is chaotic, so prediction of future states is impossible.

Advances in climate science that do not support the theory of human interference have been ignored in the UN IPCC WGI Summary for Policymakers. These include the role of clouds, solar variation, lunar influence, orbital cycles, decadal oscillations and more. If anything, the science today provides less support for the theory of human interference than it did in 1995, when the IPCC Second Assessment Report was completed.

Perhaps the most egregious omission is the emerging understanding of the chaotic nature of climate. Not only is this science very important, but it is presented in considerable detail in the TAR itself (see below). About one half of chapter 14 of the WGI TAR is devoted to discussing the deep significance of the fact that climate processes are chaotic and therefore unpredictable. But the SPM does not even mention the word "chaos".

Likewise, the draft UN IPCC WGI Technical Summary (TS), which was written by the same people as the SPM, has but a single sentence on chaos, tucked away on page 78. It says: "**The climate system is a coupled non-linear chaotic system, and therefore the long-term prediction of future exact climate states is not possible. Rather, the focus must be upon the prediction of the probability distribution of the system's future possible states** by the generation of ensembles of model solutions."

In plain language, the kind of prediction the UN IPCC is doing is not possible. The best that might be done is to provide a probability distribution for possible futures, but the IPCC does not do this. The profound fact of chaotic climate is simply ignored.

What makes this omission so egregious is that the chaotic nature of climate is discussed in the WGI TAR itself, which the SPM and TS are supposed to be summarising. Here are some statements from the expert review draft TAR, chapter 14 (the order has been changed for clarity):

**"In sum, a strategy must recognise what is possible.** In climate research and modelling, we should recognise that we are dealing with a coupled non-linear chaotic system, and therefore that the prediction of a specific future climate state is not possible.

The most we can expect to achieve is the prediction of the probability distribution of the system's future possible states by the generation of ensembles of model solutions. **This reduces climate change to the discernment of significant differences in the statistics of such ensembles. The generation of such model ensembles will require the dedication of greatly increased computer resources and the application of new methods of model diagnosis.**"

In short, it cannot now be done. Not only is prediction fundamentally impossible due to chaos, but the statistical substitute for prediction that may be possible cannot now be done. The uncertainty is complete. Chapter 14 includes these statements:

"The climate system is particularly challenging since it is known that components in the system are inherently chaotic and there are central components which affect the system in a non-linear manner and potentially could switch the sign of critical feedbacks. The non-linear processes include the basic dynamical response of the climate system and the interactions between the different components."

"These complex, non-linear dynamics are an inherent aspect of the climate system. Amongst the important non-linear processes are the role of clouds, the thermohaline circulation and sea ice. There are other broad, non-linear components: the biogeochemical system and, in particular, the carbon system, the hydrological cycle and the chemistry of the atmosphere."

"A strategy to advance our understanding must deal with the underlying chaotic nature of the climate system and the significant non-linearities. The chaotic aspect of the climate system poses significant challenges to predicting changes in the occurrence of extreme events."

"An overriding challenge to modeling and to the IPCC is prediction. This challenge is particularly acute when predictive capability is sought for a system that is chaotic, that has significant non-linearities and that is inherently stiff."

"However, as the temporal horizon grows, then the challenge shifts as

chaotic elements begin to affect the evolution of the system. The predictive environment shifts from one of precision to one of statistical significance."

"There is a growing recognition in the scientific community and more broadly that the Earth functions as a system, with properties and behaviour that are characteristic of the system as a whole. These include critical thresholds, switch or control points, strong non-linearities, teleconnections, chaotic elements and unresolvable uncertainties. Understanding components of the Earth System is critically important, but is insufficient on its own to understand the functioning of the Earth System as a whole."

Chaos is a fundamental uncertainty in climate science, but the UN IPCC ignores it.

### The Influence of Solar Variation

The most systematic omission in the Third Assessment Summary for Policymakers is discussion of warming due to natural climate variation.

Evidence of natural climate temperature variation has mushroomed since the release of the 1995 Second Assessment Report. But the TAR SPM only mentions one of the many variations now known to exist: variable solar input, or incoming solar radiation

**The UN IPCC has ignored major scientific advances that undercut the theory of human interference, including the complex chaos science that is presented in the Third Assessment Report itself.**

(called "insolation"). It is worth seeing how the SPM handles the variable insolation that is now generally accepted to occur.

At the time of the SAR, the theory that solar variation contributed to the 20th-century surface temperature run-up was well known but considered speculative. So the SAR dismissed this influence and argued that the entire increase was due to human interference. Since then, the influence of solar variation on climate change has been generally accepted, and the TAR SPM acknowledges it. However, it does so in a way that both obscures and minimises the effect.

The discussion of solar variation is on page 9, beginning with the following headline: "*Natural factors have made small contributions to radiative forcing over the past century.*" This headline dismisses the effect of all natural variations as "small". But the two variations actually considered are solar radiation and volcanic aerosols. For solar, on the very preceding page in figure 3, our understanding of the degree of forcing is said to be "very low". This statement therefore expresses a false degree of confidence.

By the IPCC's own assessment, the solar forcing could be quite large. This is actually acknowledged, but then dismissed, in the first paragraph: "*The radiative forcing due to changes in solar irradiance for the period since 1750 is estimated to be about +0.3 W/m<sup>2</sup>, most of which occurred during the first half of the 20th century. Since the late 1970s, satellite instruments have observed small oscillations due to the 11-year solar cycle. Mechanisms for the amplification of solar effects on climate have been proposed, but currently lack a rigorous theoretical or observational basis.*"

The first sentence is quite telling, for it admits that solar variation is generally accepted to have contributed significantly to the first of the two recorded 20th-century warming periods. As SPM figure 1a shows, all of the lasting warming in the 140-year surface record occurred in just two relatively brief periods—from 1910 to 1940, and from 1980 to the present. Some well-known scientists argue that solar variation is sufficient to explain all of the warming in the first period, which is what the first sentence alludes to but studiously fails to discuss. Instead, it "estimates" the forcing to be small, ignoring our "very low" understanding. That the variation is small is well known. The size of the effect, however, is unknown and extremely controversial.

The second sentence is an attempt to refute well-known arguments that solar variation can also explain the warming in the second period. The SPM acknowledges that there has been variation during this period, an observation verified by satellite, but again dismisses the effect as "small".

The third sentence is the most egregious as far as biased assessment is concerned. It first acknowledges, then dismisses out of hand the large amount of scientific literature on how a small solar variation might amplify to affect climate significantly. This sentence is actually false, because there are both theoretical and observational bases for these proposals. In fact, the starting point for this literature is the strong, and well-known, correlation

between solar activity and the warming record. A correct assessment would be that solar variation is a plausible, but as yet unverified, explanation for all the warming shown in the surface record. The TAR SPM assessment of this science is quite different, and therefore quite biased.

Moreover, the acceptance of the significant role of solar variation in the first warming period raises a broader issue. Greenhouse gas levels have been rising for over 140 years, but their warming effect, if any, is increasingly confined to just the last 20 years or so. This is a significant change since the 1995 SAR in the basis for the human interference theory, yet it is not acknowledged. One would expect a corresponding decrease in the projected future impact of increasing GHGs, but this, too, is missing.

Finally, given that we have only recently verified the significant role of solar variation in the first period of recorded warming, it seems logical to suspend judgment on the cause of the second-period warming—especially since there are known reasons to believe that it, too, may be solar in origin, in whole or in part.

This caution is doubly called for, given that there are several other climate variations that can equally well claim to cause the two observed warming periods. Contrary to what the TAR SPM asserts, the scientific situation is completely open at this point.

#### Natural Climate Variation

Evidence of naturally variable climate processes, including natural warming, has mushroomed since the 1995 IPCC Second Assessment. But the Third Assessment SPM does not even mention most of these processes, nor do the climate models include these powerful variables. These are major systematic omissions. In fact, the SPM concludes on page 10 that: "*There is new and stronger evidence that most of the warming observed over the last 50 years is attributable to human activities.*"

What the SPM ignores is that there is also "new and stronger evidence" that all of the warming is attributable to natural variation. This is an artful

subterfuge. It is a paradox in the logic of evidence that there can be at once "new and stronger evidence" for each of two contending theories in science.

In fact, there are now multiple natural variations, any one of which can explain the observed warming in the surface temperature record. Some of these are listed below:

- To begin with, there is the discovery of two enormous natural climate oscillators on the decade-to-century scale. These are called the Pacific Decadal Oscillation and the North Atlantic Oscillation. The temperature variations associated with these oscillators are sufficient to explain the entire rise shown in the 140-year surface temperature record. But the SPM does not even mention them.

- Secondly, there is a dramatic finding regarding the Moon's possible influence on climate. The ocean drives the climate and two-thirds of the ocean's mixing energy comes from the Moon, which stirs the oceans twice a day. It has been demonstrated that

**This caution is doubly called for, given that there are several other climate variations that can equally well claim to cause the two observed warming periods.**

multi-century variations in the Moon's influence correspond with the variations in the estimated temperature record. This effect, if confirmed, is also sufficient to explain the entire rise in the 140-year temperature record, as well as prior variations found in proxy records.

- Thirdly, there is a well-known (not recently discovered) oscillation that the SPM chooses to ignore. The period of the Middle Ages was warm, quite possibly as warm as today. This warm period was followed by several centuries of cold, called the Little Ice Age, which ended around 1850. The present warming may therefore be simply a recovery from the Little Ice Age, part of a multi-century natural oscillation, and some scientists have argued for this.

- Fourthly, solar variation is now accepted as playing a significant part in at least one of the two periods of warming in the 140-year surface temperature record. (As SPM figure 1a shows, all of the lasting warming in the 140-year surface record occurred in just two relatively brief periods—from 1910 to 1940, and from 1980 to the present.) Some scientists argue that solar variation can explain all of both warmings.

- Lastly, new models of the well-known Milankovitch orbital forcing predict that we *should* be in a warming period.

The SPM does not allow for these powerful natural influences, with the exception of a small solar forcing, and nor do the climate models themselves.

On page 10, the SPM says the following: "*Simulations of the response to natural forcings alone (i.e., the response to variability in solar irradiance and volcanic eruptions) do not explain the warming in the second half of the 20th century...*

*However, they indicate that natural forcings may have contributed to the observed warming in the first half of the 20th century.*"

This paragraph makes clear that the only natural variations considered by the computer models are solar radiation and major land-based volcanic activity. The massive forces and oscillators listed above are simply ignored.

The correct assessment of the science is that there are many possible explanations for the observed surface temperature rise, any one of which is sufficient to explain the entire increase. Moreover, most of these contending explanations depend solely on a natural variation.

I call this emerging view of climate as a vast, ever-changing, dynamic process the Theory of Integrated Climate Variation. This theory views changing climate as natural, something to be prepared for—not something that can be altered or prevented. On this view, the slight surface warming observed over the last century or so is also natural—not the result of human interference.

Thus, the underlying scientific debate is between the Theory of Human Interference with Climate and the Theory of Integrated Climate Variation.

Natural variation is a new way of understanding climate, which the climate models mistakenly take to be unchanging. If the theory of integrated climate variation is correct—and there is a great and growing body of evidence for it—then this assumption of invariance by the climate modellers is simply a fundamental error.

## UN IPCC Scientific Working Group Lead Authors

Many of the Working Group I SPM lead authors are prominent activists for the theory of human interference, as opposed to the theory of integrated climate variation.

The press often says the UN IPCC reports are produced by hundreds, if not thousands, of scientists. This may be true in some vague sense of participation, and the actual TAR chapters do not exhibit as much glaring scientific bias as the WGI Summary for Policymakers and the Technical Summary.

On the other hand, only experts read the main reports. The UN IPCC's voice to policymakers, press and the public regarding climate science is through the WGI SPM and the TS. These two documents have precisely the same 20 lead authors, many of whom are among the leading proponents of the theory of human interference with climate.

Here are the 20 lead authors listed by the UN IPCC (the names in bold typeface stand out in particular as among the top rank of activist scientists for the theory of human interference with climate; most of them are frequently quoted in the American and British press):

*Coordinating lead authors* – D. L. **Albritton** (United States of America), L. G. Meira Filho (Brazil).

*Lead authors* – U. **Cubasch** (Germany), X. Dai (China), Y. Ding (China), D. J. Griggs (United Kingdom), B. Hewitson (South Africa), J. T. **Houghton** (UK), I. Isaksen (Norway), T. **Karl** (USA), M. McFarland (USA), V. P. Meleshko (Russia), J. F. B. **Mitchell** (UK), M. **Noguer** (UK), B. S. Nyenzi (Tanzania), M. **Oppenheimer** (USA), J. E. Penner (USA), S. Pollonais (Trinidad and Tobago), T. Stocker (Switzerland), K. E. **Trenberth**

(USA).

It is no wonder, therefore, that the two summaries are so blatantly biased in favour of the theory of human interference with climate. They are written by scientists who have staked their reputations on that theory. This sort of bias need not be politically motivated. Most articles in the scientific literature are advocating some theory or other.

Again, what is really going on in the science is a debate between the Theory of Human Interference with Climate and the Theory of Integrated Climate Variation.

### About the Author:

Dr David E. Wojick has a PhD in mathematical logic and philosophy of science from the University of Pittsburgh, and a Bachelor of Science in civil engineering from Carnegie Mellon University. He has been on the faculty of Carnegie Mellon, where he helped found both the Department of Engineering and Public Policy and the Department of Philosophy. He has also served with the Office of Naval Research and the Naval Research Laboratory.

David is presently a freelance writer, covering climate change issues for *Electricity Daily*, as well as a policy analyst. A résumé and client list are available at <http://www.bydesign.com/powervision/resume.html>. For further information and discussion, email David at [dwojick@climatechangedebate.org](mailto:dwojick@climatechangedebate.org) or visit his website at <http://www.climatechangedebate.org>.

**Natural variation is a new way of understanding climate, which the climate models mistakenly take to be unchanging.**

# DEATH BY DOCTORING

***Vitamins C and B17  
(also called laetrile)  
have longstanding  
success in cancer  
prevention and  
treatment, yet the  
orthodox medical  
profession  
continues to deny  
their benefits.***

***Part 2 of 2***

**by Steven Ransom © 2002**

Research Director  
Credence Publications, UK  
Telephone: +44 (0)1622 832386  
Email: [steve1@onetel.net.uk](mailto:steve1@onetel.net.uk)  
Website: <http://www.credence.org>

Extracted from his book  
*Great News on Cancer in the 21st Century*  
(Credence, 2002)

## REPUTATION IS EVERYTHING

**B**ut what relevance does all this have to the debate on treatments for cancer? Where is all of this headed? This has been a necessary diversion—firstly, that we might begin to understand some of the frustrations that many reasoned thinkers have with the issues raised; and secondly, that we might begin to consider the impact that such weakened thinking has on genuine natural treatments for disease. For instance, what damage is secondarily being wrought upon the reputation of the genuine treatments in the cabinet, the ones that can actually heal?

Sadly, there is no clear division between the reputation of much of the unregulated alternative health industry and that of the many sensible and proven, non-conventional treatments available today. It has all become a horrible blur and is a point of major concern even to the non-orthodox regulatory bodies overseeing the alternative/complementary health movement. The whole arena is fraught with as many vested interests and misunderstandings as conventional health, but commentaries drawing such conclusions—even from those concerned bodies sympathetic to the natural approach—are viewed as almost heretical and somehow betraying the brotherhood of the alternative hierarchy.

Personally speaking, critical debate should commence as soon as possible with regard to those "helping" therapies that only temporarily distract the seriously ill. In need only of sensible advice and sensible treatment, these people can very quickly end up worse off in body, mind and spirit—and, last but not least, in pocket—leading very quickly to derision and a *carte blanche* dismissal of all the good that genuine natural treatments have to offer.

John Diamond stated that there was as much chance of his going down the alternative treatment route as there was of the Pope getting drunk on the communion wine and getting off with a couple of nuns.<sup>18</sup> Whilst we can perhaps understand some of John Diamond's frustrations, his comparisons don't exactly aid the cause. Because the truth is that the alternativist's cabinet is not all "mumbo jumbo" by any means. Genuine medicine can be found in there.

Perhaps a name change is in order. Are we alternative? Are we complementary? But complementary to what? To chemotherapy, perhaps? But then, what medicine could possibly complement chemotherapy? Shouldn't there just be medicine and non-medicine, full stop? Be that as it may, many people are wrongly assuming that the non-orthodox medical cabinet is barren and not worthy of closer inspection.

The hazy and often crazy information being disseminated on numerous non-conventional treatments, coupled with our innate and naïve trust in the orthodoxy, is the reason why thousands of people like John Diamond are staying with, and relying upon, conventional treatments for serious illnesses including cancer. As a result, thousands of people like John Diamond are dying, and often in a horrible fashion.

## Vitamin B17

In his UK *Observer* article entitled "Quacks on the Rack", John Diamond summarily dismissed what is arguably the most famous of the natural and proven anti-cancer treatments known to man: the natural extract of the apricot kernel, otherwise known as vitamin B17.

"Supporters of laetrile (vitamin B17) and Essiac, in particular, made so much noise about their miracle cures that both have been through the research mill on numerous occasions and found to be useless."<sup>19</sup>

Now we can ask ourselves whether it was perhaps the fault of some kindly but misguided soul who posted John Diamond an essay on the benefits of vitamin B17 mixed with walnut water which caused him to dismiss B17 so emphatically. Or was it that John actually trusted the conventional research reports he had accrued on this vitamin?

Interestingly, Dr Dean Burk, the former head of the Cytochemistry Department of the National Cancer Institute and one of the co-founders of this famous American medical institution, had personally worked on vitamin B17. He described this substance in very different terms:

"When we add laetrile to a cancer culture under the microscope," said Dr Burk, "providing the enzyme glucosidase also is present, we can see the cancer cells dying off like flies."<sup>20</sup>

(Glucosidase is the enzyme heavily present in cancerous cells, which triggers the unique cancer-destroying mechanism found in vitamin B17. An excellent clinical analysis of this mechanism is found in *B17 Metabolic Therapy – In the Prevention and Control of Cancer*, a concise history of the research into this vitamin, including many clinical assessments.<sup>21</sup>)

Dr Burk also stated that evidence for laetrile's efficacy had been noted in at least five independent institutions in three widely separated countries of the world.<sup>22</sup>

So whom do we trust in this matter? Diamond or Burk? By looking at where John Diamond might have got his B17 research "information", the ugly features of conventional cancer research move more sharply into focus.

### Because of the Money

Cancer is big business, and knowledge claims on any treatments

that earn money and, conversely, on any treatments that do not earn money for the drug companies are never neutral.

Dr Ralph Moss served as the Assistant Director of Public Affairs at America's most famous cancer research institution, Memorial Sloan-Kettering in Manhattan. He knows the cancer industry inside out. Read what he had to say in an April 1994 interview with Laura Lee, and judge for yourself the quality of the evidence against the effectiveness of vitamin B17:

Dr Moss: "Shortly after I went to work [at the Sloan-Kettering Cancer Institute], I visited the elderly Japanese scientist Kanematsu Sugiura, who astonished me when he told me he was working on laetrile (B17). At the time it was the most controversial thing in cancer, reputed to be a cure for cancer. We in Public Affairs were giving out statements that laetrile was worthless, it was quackery, and that people should not abandon proven therapies. I was astonished that our most distinguished scientist would be bothering with something like this, and I said, 'Why are you doing this if it doesn't work?' He took down his lab books and showed me that, in fact, laetrile was dramatically effective in stopping the spread of cancer."

Laura Lee: "So this is verified, that laetrile can have this positive effect?"

Moss: "We were finding this and yet we in Public Affairs were told to issue statements to the exact opposite of what we were finding scientifically."<sup>23</sup>

Unable to sit on this information, Dr Moss later called a press

conference of his own and, before a battery of reporters and cameramen, charged that Sloan-Kettering officials had engineered a massive cover-up. He provided all the supporting documents and named all the names necessary to validate his case. The following day he was fired for "failing to carry out his most basic job responsibilities".<sup>24</sup>

Similarly, in his book, *World Without Cancer*, cancer industry researcher G. Edward Griffin notes:

"Every laetrile study had been tarnished with the same kind of scientific ineptitude, bias and outright deception... Some of these studies openly admitted evidence of anti-cancer effect, but hastened to attribute this effect to other causes. Some were toxicity studies only, which means that they weren't trying to see if laetrile was effective, but merely to determine how much of it was required to kill the patient."<sup>25</sup>

The "evidence" supporting John Diamond's claim that vitamin B17 is useless and even dangerous is available in abundance in all of the major cancer institutions today. Well, of course it is! We're in the merchant's house, don't forget!

As Pat Rattigan, author of *The Cancer Business*, reports:

"The threat to the cancer business from effective therapies was taken very seriously from the beginning. By the 1940s, the Syndicate had 300,000 names on its 'quack' files. Vitamin B17, being a unique threat due to its simplicity, attracted more concentrated attacks than all the other treatments put together: fraudulent test reports; hired, banner-carrying pickets outside clinics; rigged juries; newspaper character assassinations; dismissal of heretic employees; etc. The FDA, orchestrating the onslaught, sent out 10,000 posters and hundreds of thousands of leaflets warning about the dangers of the

toxicity of the non-toxic substance. Earlier, a Congressional Accounting Office had found that 350 FDA employees had shares in, or had refused to declare an interest in, the pharmaceutical industry."<sup>26</sup>

The American Food and Drug Administration issued one such story about the death of an 11-month-old girl, supposedly from cyanide poisoning due to her apparently swallowing her father's vitamin B17 tablets. Cancer specialist and B17 advocate Dr Harold Manner takes up the story:

"I was lecturing in Buffalo, New York and...after I had made some strong statements, a man stood up and said, 'Dr Manner, how in the world can you make statements like that when the FDA is making these other statements?' I reiterated that the FDA statements were lies. He said, 'Look at this little girl in upstate New York; she took her father's laetrile tablets and died of cyanide poisoning.' Just then, a little lady stood up: 'Dr Manner, let me answer that question. I think I am entitled to because I am that little baby's mother. That baby never touched her father's laetrile tablets. The doctor, knowing the father was on laetrile, marked down "possible cyanide poisoning". At the hospital they used a cyanide antidote and it was the antidote that killed the child. And yet that statement will continue to appear, even though they know it is a lie."<sup>27</sup>

The scare stories always focus on the minute amounts of naturally occurring cyanide found in vitamin B17. But no mention is made in any of these stories of the wondrous

**"When we add laetrile to a cancer culture under the microscope," said Dr Burk, "providing the enzyme glucosidase also is present, we can see the cancer cells dying off like flies."**

mechanism governing the release of this cyanide. No harm is done to the person eating this vitamin (if that were the case, we've consumed enough apricots, apples, peaches, cherries, etc. containing B17 to have finished us off long ago). The cyanide is released only when cancerous cells are recognised by their high glucosidase content. B17 cyanide attacks cancer cells specifically. No large amounts of glucosidase detected means no cyanide release. Rest assured, there is no evidence that vitamin B17 can kill—unless, of course, one is accidentally crushed under a pallet of the stuff!

A further embarrassment for the cancer orthodoxy must surely

be the research being carried out at the Imperial College in London, where researchers are looking at ways of using naturally occurring plant cyanide specifically to attack human bowel tumours. The idea came about after studying the pattern of specific cyanide release in the almond and cassava fruit which protects them from insect attack. Another one of those natural wonders, just crying out to be heard, is at last being listened to by the orthodoxy, perhaps?<sup>28</sup>

Very sadly, in assessing the deservedness of the "shady" reputation bestowed upon vitamin B17 metabolic therapy, we realise it is entirely unwarranted and that, instead, there has been a sustained attack by the conventional cancer industry on this treatment—an attack that has been carried on in one form or another for the last 40 years.

As mentioned earlier, with global spending on conventional cancer running into the hundreds of billions annually, a naturally occurring cancer cure of any description is an unwanted intruder.

Here is Dr Moss, again from the April 1994 Laura Lee interview, this time on the money involved in conventional cancer:

Moss: "About 630,000 people die every year of cancer in the US, and it really is an epidemic disease. We have got a tremendous industry. Every one of those people who is getting cancer and dying of it is going to be treated, and these treatments are extremely expensive. Chemo is [costed at] tens of thousands, sometimes hundreds of thousands of dollars. A bone marrow transplant, which is basically another way of giving chemotherapy, or radiation, can run to about \$150,000 per person, and is almost never effective. It kills about 25 per cent of the patients."

Lee: "Why carry on doing it?"

Moss: "Because of the money, which is tremendous."<sup>29</sup>

When we understand the amounts of money involved, we can begin to understand the in-house desire to sustain a "fact-creating" process in support of conventional treatment. Conventional cancer treatment and cancer research are a licence to print money. Most definitely, conventional interested parties and institutions have colluded in a shameful anti-vitamin B17 "fact-creating" process, which in turn has surely led to the early and unnecessary deaths of thousands upon thousands of people.

As for John Diamond's dismissal of vitamin B17, he didn't write his comments on B17 as an intentional slur. He wasn't the forked tongue in this chain of events. He desperately wanted to

live. His single paragraph read by thousands was just another example of the damaging knock-on effect of merchant-speak. Merchant-speak on vitamin B17 metabolic therapy has exacted a grave injustice upon this treatment, and subsequently upon all who have been persuaded to think likewise.

Let's now look at some testimonies from those who have not been persuaded by the negative propaganda.

#### • Phillip

Phillip is 64. In April 2001, he was diagnosed with inoperable lung cancer. The oncologist showed him the X-rays that con-

firmated the dreaded "shadows". He was told to go home, enjoy his life as best he could and put his affairs in order.

A week later, in a chance conversation at work, Phillip was told about vitamin B17. Phillip immediately began taking a combination of vitamin B17 and vitamin C. Four months later, Phillip returned to hospital for a check-up, where a new set of X-rays was taken. The shadows had completely disappeared. Says Phillip:

"I know what I saw, and the doctor couldn't explain it. I'm continuing with my vitamin B17 regime and eating about 10 kernels a day."<sup>30</sup>

Phillip now pays great attention to his diet and believes that what we put into our bodies can have a dramatic effect medicinally.

#### The Importance of Nutrition

Here's John Diamond again, this time on some "nutter" with a magical diet:

"I was waiting my turn for zapping [radiation] one day and mentioned the ludicrousness of one diet I'd been reading about. The radiographer agreed and said that when she had started at the hospital there used to be a nutter

who, having refused radiography, would come down and rail against those sitting in the radiotherapy waiting room, telling them they should abandon evil radiation and take up his magical diet. 'Criminal,' I said. 'You kicked him out, of course?' 'Well yes,' she said, 'we kicked him out regularly. The only thing was, he did survive for years and the cancer did disappear.' Which only goes to prove—well, nothing very much at all, really, but I thought I'd pass it on in the name of fair dealing."<sup>31</sup>

Now if this cancer "nutter" was just an isolated case of recovery through diet, his recovery would not of course constitute proof. But with vitamin B17 metabolic therapy, we are seeing tremendous results time after time. Continuing on in the name of fair dealing...

#### • William

William was diagnosed with a tumour in the oesophagus. He could not swallow food without it being liquidised. He had read about vitamin B17 12 months previously and had kept the article. William began taking vitamin B17 soon after the diagnosis. After three weeks he was swallowing food a lot easier, and after about seven weeks he was told by his doctor that the only reason for this was because the tumour was shrinking.

Says William: "The operation to remove the tumour was

**Conventional cancer treatment and cancer research are a licence to print money.**

**Most definitely, conventional interested parties and institutions have colluded in a shameful anti-vitamin B17 "fact-creating" process...**

cancelled and I am still awaiting the results of the latest scan. I feel fit as a fiddle. I pay attention to my diet and I thank God quite literally for vitamin B17. It is time the NHS [National Health Service] recognised this vitamin as an alternative to the conventional treatments. I consider that any money spent on B17 is money well spent."<sup>32</sup>

### What Are We Eating?

It is interesting to note that there are cultures today who remain almost entirely cancer free. The Abkhasians, the Azerbaijanis, the Hunzas, the Eskimos and the Karakorum all live on foodstuffs rich in nitriloside or vitamin B17. Their food consists variously of buckwheat, peas, broad beans, lucerne, turnips, lettuce, sprouting pulse or grain, apricots with their seeds, and berries of various kinds. Their diet can provide them with as much as 250–3,000 mg of nitriloside a day. The founding father of vitamin B17 research, Ernst T. Krebs, Jr, studied the dietary habits of these tribes. Krebs stated:

"Upon investigating the diet of these people, we found that the seed of the apricot was prized as a delicacy and that every part of the apricot was utilized."<sup>33</sup>

The average Western diet, with its refined, fibreless foods, offers less than 2 mg of nitriloside a day. It has also been noted that natives from these tribes who move into "civilised" areas and change their diets accordingly are prone to cancers at the regular Western incidence.<sup>34</sup>

### The Right Materials

In his book, *Preface to Cancer: Nature, Cause and Cure*, Dr Alexander Berglas has this to say about cancer incidence:

"Civilization is, in terms of cancer, a juggernaut that cannot be stopped... It is the nature and essence of industrial civilization to be toxic in every sense... We are faced with the grim prospect that the advance of cancer and of civilization parallel each other."<sup>35</sup>

The human body has an amazing capacity to recover, if we look after it properly and if we supply it with the proper materials for repair. Working with non-toxic, physio-friendly treatments can only work in our favour. Just look at the side-effects of vitamin B17 as described by G. Edward Griffin in *World Without Cancer*:

"B17 side effects include increased appetite, weight gain, lowered blood pressure, increased hemoglobin and red blood cell count, elimination or sharp reduction of pain without narcotics; builds up the body's resistance to other diseases, is a natural substance found in foods and is compatible with human biological experience, destroys cancer cells while nourishing non-cancer cells..."<sup>36</sup>

Compare the above with the side effects from chemotherapy and radiation: the dizziness, skin discolouration, nausea, diarrhoea, loss of hair, loss of appetite, organ failure, internal bleeding, etcetera, etcetera.

How long will it be before we find ourselves looking back on these treatments in the same way as we now look back on the blood-letting and ammonia infusions exacted upon King Charles II? Notwithstanding the often life-saving surgical removal of cancerous tissue, could there possibly be a more inhumane treatment in the 21st century than conventional cancer therapy?

### • Flora

Flora was diagnosed with stage-four bowel cancer in 1999.

"Before the operation they gave me chemotherapy, which was devastating. By the end of the course, I could hardly stand. They then removed the tumour from my bowel. I was told the cancer had spread to the liver. I was offered further chemotherapy, but declined. I attended Middlesex Hospital and had five sessions of laser treatment to try and contain the liver cancer, followed by more chemotherapy. After the fifth time of trying to contain the cancer, they said that it was beginning to grow yet again. So I began an organic diet and attended the Dove Clinic for intensive vitamin C treatment with other supplements. It was there that I was told about vitamin B17. I added that to my regime. Over a period of time, the cancer completely disappeared from my liver. It is now February 2002 and I have been one year clear of cancer.

I am maintaining my organic diet and eating about 50 apricot kernels a day. I'm 64, I've returned to work and I feel fine. Treatments such as these should at least be made known to patients by the NHS."<sup>37</sup>

There are literally thousands of people who can attest to the pharmacological, life-saving power of vitamin B17 and its supporting nutritional regime. And the same can also be said of vitamin C.

### Vitamin C

The all-round benefits of vitamin C to the human physiology

have been known and utilised for centuries. In terms of its benefits in cancer treatment and prevention, we read the following from Phillip Day:

"Dr Linus Pauling, often known as the 'Father of Vitamin C' and twice awarded the Nobel Prize, declared that daily intake of up to 10 grams a day of the vitamin aids anticancer activity within the body.

"Pauling was largely derided for making these declarations but, today, large doses of vitamin C are used by many practitioners for cancer patients in nutritional therapy, who believe Pauling was right and that the popular nutrient is indispensable to the body in its fight to regain health from cancer."<sup>38</sup>

Vitamin C can protect against breast cancer. After reviewing 90 studies on the relationship between vitamin C and cancer, Gladys Block, PhD, at the University of California at Berkeley, concluded:

"There is overwhelming evidence of the protective effect of vitamin C and other antioxidants against cancer of the breast."<sup>39</sup>

And Geoffrey R. Howe, of the National Cancer Institute of Canada, reviewed 12 controlled case studies of diet and breast cancer and noted that vitamin C had the most consistent statistically significant relationship to the reduction of breast cancer risk.<sup>40</sup>

On the subject of the importance of mineral and vitamin supplements, a recent *New York Times* front-page article quoted Dr Geoffrey P. Oakley, Jr, at the Centers for Disease Control and Prevention in Atlanta, as saying:

"We, the physicians, were mistaken not to recommend vitamin supplements to our patients for so long. We need just to admit that, on this one, we were wrong."<sup>41</sup>

**"...today, large doses of vitamin C are used by many practitioners for cancer patients in nutritional therapy, who believe Pauling was right and that the popular nutrient is indispensable to the body in its fight to regain health from cancer."**

Let the reader be assured that the recent scare tactics surrounding vitamin C and its supposed links to cancer are just another one of those smear campaigns orchestrated by the merchants.

Quite simply, any good news on vitamin C represents yet another threat to the pharmaceutical industry's considerable income from conventional cancer treatments. The full story on the vested interests supporting the author of the much-publicised vitamin C/cancer story can be found at the website <http://www.whatareweswallowing.freeserve.co.uk/vitc.htm>.

#### • Hazel

Hazel had been given a virtual death sentence by her cancer doctor, who told her that although there was an 86 per cent recovery rate from her type of breast cancer, she was unfortunately in the smaller category.

As previously noted, Hazel's chemotherapy was only making her feel terrible, and she decided that if she were going to die then she would do so without further conventional treatment. Hazel began a regime of intravenously administered vitamin C and supplements, including vitamin B17, and paid great attention to her diet. She soon began to feel a great deal better. She regained her weight, her hair and her appetite.

About nine months following the diagnosis, she was troubled with lower back pain and visited her doctor. He suggested a further scan based on Hazel's lower back pain, which the doctor believed was possibly the result of her cancer having spread to the base of her spine. Hazel said there was no way she was going for more chemotherapy or scans, which she believes in themselves can trigger carcinogenic activity.

Instead, Hazel supplemented her vitamin C regime with a course of vitamin B17 kernels, and she also maintained a sensible diet and stayed away from her conventional cancer physician. The blood count taken by her GP before Christmas read as normal. She feels very healthy and is in the process of writing a book about her experiences. She feels passionately that people need to know that there are alternative cancer treatments available, and she speaks to groups on this subject.<sup>42</sup>

#### Need for Data and Education

Finally, we hear from Dr Nicola Hembry of the Dove Clinic, which specialises in the non-conventional approach to cancer care and treatment:

"Nutritional treatments such as high-dose vitamin C and B17 [laetrile] have been known about for years, and there are many success stories from patients lucky enough to have received and benefited from them. Research shows that levels of 400 mg/dL vitamin C in the blood can kill cancer cells by a pro-oxidative mechanism, and there is a great deal of data showing that B17 is preferentially toxic to cancer cells.

"The trouble is that there is little in the way of well-designed random control trial data for the use of these substances, and therefore mainstream medicine rejects them out of hand without even considering the evidence available or even asking why these

trials haven't been carried out. It has to be said that one of the reasons is a lack of financial incentive because these substances cannot be patented.

"Sadly, it is the cancer sufferers who lose out. To not even have the choice of these safer, more natural treatments, even when a cancer is deemed incurable and only palliative chemotherapy or radiotherapy is offered, is in my view totally unacceptable. I have seen many patients experience an improved duration and quality of life with an integrated approach, and some go on to achieve complete remission of their disease, even when dismissed as incurable by their oncologists."<sup>43</sup>

Treating cancer is not just about getting hold of vitamin B17 as quickly as possible. We need to be educated in a whole range of issues. Phillip Day's book, *Cancer: Why We're Still Dying To Know The Truth*, has been written in an easily readable and understandable manner, specifically to inform the general public on all of the key issues pertaining to natural treatment for cancer. It makes for necessary and fascinating reading.

For those readers interested in finding out more on the issues raised in this article, just click on the following titles available from Credence Publications at the website <http://www.credence.org>:

- *Cancer: Why We're Still Dying To Know The Truth* – A concise account of the cancer industry and of the good news on vitamin B17 metabolic therapy.

- *Vitamin B17 Metabolic Therapy: A Clinical Guide* – A clinical account of vitamin B17, detailing the landmark research on this most vital of vitamins in the fight against cancer.

- *Food For Thought* – Delicious recipes designed to promote health. A vital contribution to cancer prevention and recovery.

#### Closing Comments

Throughout the writing of this article, I have been acutely aware of

three things.

Firstly, I've been aware of my slender mortality and that only by the grace of God have I not had to face a cancer diagnosis of my own. I know that for many, the information contained in "Death by Doctoring" will bring sadness as well as anger. But in its telling, I also believe this story brings great hope.

Secondly, vitamin B17 metabolic therapy and vitamin C form only part of a much wider regime of treatments that have proven successful in the treatment of cancer. These and other sensible treatments are explained in more detail in the above Credence titles.

Thirdly, I am conscious of the fact that there are elements of conventional medical practice that are saving and enhancing lives every day, not least in some methods of early cancer diagnosis and in acute and emergency medicine. May the good continue, and may the bad be open to complete reappraisal.

Finally, I do so wish I'd been given the opportunity to meet John Diamond, because I reckon we'd have got on like a house on fire. And who knows what might have happened as a result?

**Quite simply, any good news on vitamin C represents yet another threat to the pharmaceutical industry's considerable income from conventional cancer treatments.**

**Continued on page 83**



# UNCOVERING THE FACTS ON TOXIC CARPET

***Carpets, both new and old, are a hazard to health because they offgas volatile chemical compounds, can contain heavy metal residues and harbour dust mites and harmful allergens.***

**by Jenny Hawke © 2002**

NEXUS Magazine  
PO Box 30  
Mapleton, Qld 4560  
Telephone: +61 (0)7 5442 9280  
Email: nexusmagazine@optusnet.com.au

*Editor's Note: Several mentions of animal experiments are made in this article. NEXUS does not agree with the practices of animal experimentation and vivisection, but we also don't want to censor the articles we publish.*

**C**arpet is a big part of people's lives in many countries. It keeps us warm, absorbs noise and can feel soft and look attractive. Over 90% of homes are carpeted in the UK, 65% in Germany and 60% in the USA.<sup>1</sup> However, there are concerns related to carpeted dwellings and workspaces. Carpet emits toxins which are harmful to health, and old carpet traps pesticide residues in addition to dust containing lead and other heavy metal residues. Carpet also has consequences for the environment.

## **CHEMICALS IN NEW CARPET**

New carpets release chemicals that are detrimental to health, particularly in the first few days after installation. The United States Environmental Protection Agency (US EPA) recommends purchasers request low-toxin-emitting carpet, cushioning and adhesives as well as ask that the new carpet be well ventilated before being laid. The US EPA further advises buyers to "consider leaving the premises during and immediately after installation, or schedule the installation when the space is unoccupied".<sup>2</sup>

New synthetic carpets offgas volatile organic compounds (VOCs) such as formaldehyde, ethylbenzene, toluene, xylene, acetonitrile, styrene, trichloroethylene, azulene, benzene, diphenyl ether and dodecane.<sup>3</sup> Some of these substances are on the US EPA's List of Extremely Hazardous Substances:<sup>4</sup>

- Formaldehyde is included on the list and "can cause watery eyes, burning sensations in the eyes and throat, nausea and difficulty in breathing in some humans exposed at elevated levels (above 0.1 parts per million)".<sup>5</sup> It is a carcinogen and can cause dermatitis, aggressive behaviour, bronchial spasm and other medical conditions.<sup>6</sup>

- Ethylbenzene has caused tumours in rats and mice, neurological effects in humans, throat and ear irritation and chest constriction. Other animal studies have reported foetal resorptions, skeletal deformations and an increased incidence of extra ribs.<sup>7</sup>

- Toluene in high levels can cause birth defects in humans,<sup>8</sup> and has made it to the EPA's Community Right to Know List and Toxic Substances Control Act Inventory. Effects include "fatigue, weakness, confusion, euphoria, headache, dilated pupils, dermatitis, central nervous system recording changes, psychophysiological test changes and bone marrow changes".<sup>9</sup>

- Xylene is on the EPA lists and causes some similar effects including vomiting, abdominal pain, coordination problems, weight loss, excitement, drowsiness and staggering gait.<sup>10</sup>

- Acetone makes it onto the EPA's lists and can react vigorously with oxidising chemicals. It is considered "a severe irritant", and "Human systemic effects by inhalation include changes in electroencephalogram, changes in carbohydrate metabolism, nasal effects, respiratory system effects, nausea, vomiting and muscle weakness".<sup>11</sup>

- Styrene, used in carpet backing, is a suspected carcinogen and irritant,<sup>12</sup> has caused adverse reproductive effects in animals and can cause "eye and nose irritation, drowsiness, olfactory (smell) changes, and defatting dermatitis".<sup>13</sup>

- Benzene, a known carcinogen,<sup>14</sup> can produce myeloid leukaemia, Hodgkin's disease and lymphomas. It is a poison by inhalation and a skin and eye irritant. Birth defects and

adverse reproductive effects were found in animals exposed to benzene, and effects were seen at less than one part per million.<sup>15</sup>

Other chemicals found in carpet include bis(2-ethylhexyl)phthalate, caprolactum, diethylene glycol, p-Dichlorobenzene, hexane and vinylcyclohexene.<sup>16</sup> Bis(2-ethylhexyl)phthalate, diethylene glycol and vinylcyclohexene are suspected carcinogens, and p-Dichlorobenzene is a known carcinogen which can produce minor irritations as well as cirrhosis of the liver. Caprolactum and hexane have caused foetal abnormalities in animals, and hexane can induce nausea and various other mild symptoms. In humans it has brought about hallucinations, structural changes in nerves, motor neuropathy and respiratory irritation.<sup>17</sup>

In 1988, more than 500 complaints were made to the US Consumer Product Safety Commission (CPSC) regarding health problems related to carpet (see the website <http://www.cpsc.gov/cpsc/pub/pubs/454.htm>). The CPSC then commissioned a study, in which 31 chemicals were identified as being released from carpets. Even though some chemicals were found in very small amounts and not thought to be dangerous, the Commission admitted the combination could create a potent cocktail. The effects of long-term exposure to the substances were not measured.<sup>18</sup>

### TOXINS IN CARPET BACKINGS AND ADHESIVES

It is important to note that carpet is not the only piece of the toxic puzzle. Some of the abovementioned chemicals are contained in backings and adhesives, thus also contributing to the noxious emissions.

One chemical, 4-PC, used in the latex backing on 95% of carpets in the US<sup>19</sup> and also used to glue backing to carpet, is the chemical that gives off that new carpet smell. It has been associated with producing eye, nose, throat, upper respiratory and other problems when people are exposed to new carpeting.<sup>20</sup> It has also been named as a suspect in the US EPA's infamous "sick building" incident of 1988; the symptoms of ill staff resolved when the carpet was replaced.<sup>21</sup> Not surprisingly, industry studies have found no toxic effects of 4-PC,<sup>22</sup> but it "continues to be emitted at measurable levels for a longer time" than other chemicals associated with carpet,<sup>23</sup> so long-term effects may be of concern.

Ethylbenzene is found in carpet glue and it produces a long list of negative health effects on humans and animals.<sup>24</sup>

Adhesives and sealants initially offgas more than carpet does in the first few weeks. Commercial installation of carpet is of particular concern as glue is spread across the floor, whereas residential application requires much less adhesive and often uses stapling around the perimeter of a room.<sup>25</sup>

Seam sealant has also been named as toxic. The chemical 1,1,1-trichloroethane was a common ingredient used in the US until government regulations stipulated that it be phased out by 1996.<sup>26</sup> However, the hazardous toluene may still be found in some sealants.

The US EPA lists moth repellents as containing volatile organic compounds.<sup>27</sup> Used commonly on woollen carpets, mothproofing is considered a "necessary evil".<sup>28</sup> Mothproofing chemicals contain naphthalene, which is "cumulatively toxic and emits vapour that can produce toxic reaction in sensitive individuals". Naphthalene is most dangerous to newborns.<sup>29</sup>

Fire-retarding measures can also prove to be toxic. In a UK study in 2000, a brominated flame-retardant chemical (BDE-209) was found in carpet in "significant levels". The Healthy Flooring Network acknowledges that safety should not be compromised, and states that other, less-toxic choices are available. These include "redesign and/or reformulation of materials to achieve lower flammability".<sup>30</sup>

### MULTIPLE CHEMICAL SENSITIVITY CONCERNS

Some people are more sensitive than others may be to toxins. Multiple chemical sensitivity (MCS) is a relatively new term applied to people suffering reactions similar to many listed above when exposed to small amounts of chemicals. The condition has also been named "toxicant-induced loss of tolerance" (TILT).<sup>31</sup> Some doctors consider the condition psychological, noting that 65% of patients with MCS have at some stage suffered from depression. Others argue to the contrary, that MCS may *cause* depression. In any event, the US EPA advises doctors that "complaints should not be dismissed as psychogenic, and a thorough workup is essential".<sup>32</sup>

MCS is caused by exposure to chemicals known as "initiators".

These include pesticides, solvents, carpets, glues and formaldehyde. Symptoms such as respiratory illness, central nervous system problems (memory loss, concentration problems, irritability, insomnia, depression, etc.), gut, muscle and joint pain and headaches can be triggered by low-level exposure to chemicals such as air fresheners, newly painted rooms, cleaning substances, solvents, tobacco smoke, etc.<sup>33</sup> All initiators listed are related to carpet, directly or by treatment or installation. Triggers may also

be related to carpet acting as a sink.

Cindy Duehring, an American woman, suffered from MCS after being poisoned by pesticides in 1985. She consequently became an activist and set up the Environmental Access Research Network (EARN), which merged with the Chemical Injury Information Network (CIIN) in 1994. A new division, the MCS Research Fund, was set up to study multiple chemical sensitivity. The fund was renamed the Cindy Duehring MCS Research Fund after Cindy died in 1999 from complications related to her initial poisoning.<sup>34</sup>

### INDUSTRY AND UNIVERSITY DENIALS

In the early 1990s, Cindy undertook extensive research into carpet and its health effects. One incident she reported involved the McIver family's experience with carpet and the carpet industry. The son, Christopher, suddenly began having convulsions on their new carpet. The parents, Jocelyn and Kevin, both lawyers, requested information from the manufacturers regarding any negative reactions associated with new carpet. They were advised in a letter from Monsanto that "We have not heard of any reactions similar to what you describe".<sup>35</sup>

It was later discovered that Monsanto had people on the board of the Carpet and Rug Institute (CRI), and the Institute was well aware of over 1,000 complaints reported by workers in the "sick building" incident at EPA headquarters. The Consumer Product Safety Commission had also stated in 1990, a year before the McIvers bought their carpet, that it would furnish the carpet industry with reports from 206 households regarding respiratory

**MCS is caused by exposure to chemicals known as "initiators". These include pesticides, solvents, carpets, glues and formaldehyde.**

and central nervous system problems related to carpet. Eventually the McIvers had their carpet removed, and Christopher's tremors completed ceased. Unfortunately, Christopher suffered a damaged immune system, consistent with chemical exposure. He also exhibited nerve tissue damage.<sup>36</sup>

Bill Hirzy, PhD, was a senior scientist at the US EPA and president of EPA Union Local 2050 at the time. He commented of the EPA that even though the sick building incident had already occurred, an information brochure still stated that "Limited research to date has found no links between adverse health effects and the levels of chemicals emitted by new carpet".<sup>37</sup>

Research published in 1995 by Cornell University dismissed reactions to new carpet as "psychogenic". Dubbed by the University as the "the most comprehensive review on the health effects of any indoor product", it acknowledged only carpet adhesives as affecting indoor air quality (IAQ) or causing sick building syndrome (SBS). Cornell pointed out that "new, low-emission adhesives...are now available, though they may be more expensive". However, the University's objectivity may be questioned due to the fact that the Carpet and Rug Institute funded this research.<sup>38</sup> A presentation is available for viewing at the CRI website (<http://www.carpet-rug.com/studies.cfm>), where this fact is not made obvious. Some slides could be mistaken for a CRI promotional presentation.

#### TEST RESULTS SWEEPED UNDER THE RUG

In the early 1990s, Anderson Laboratories undertook carpet testing for people with health complaints by employing the American Society for Testing and Materials (ASTM) E981 procedure, widely used since the 1960s.<sup>39</sup>

This involved blowing air from the carpet over mice and monitoring their reactions. Symptoms were typical of human reactions to chemicals, such as burning eyes and nose, difficulty breathing and even tremors.<sup>40</sup>

The Anderson Laboratories tests were dismissed by many as invalid. Hal Levin, an air quality expert, stated that the methodology was not scientifically valid.<sup>41</sup>

The US EPA replicated the results in Anderson Laboratories, using its own new carpet sample and its own equipment. However, when the EPA attempted to replicate the test in its own laboratories, the results were not as conclusive.<sup>42</sup>

Bill Hirzy stated that the EPA created its own protocol, changing the humidity so toxins were absorbed by moisture in the air, making the air clean.

The Carpet and Rug Institute also asked Dr Yves Alarie (who developed the ASTM E981 test in the 1960s) from the University of Pittsburgh to replicate Anderson's tests. Dr Alarie testified before the Committee on Government Operations, Subcommittee on Environment, Energy and Natural Resources, US House of Representatives, on June 11, 1993 that "Her [Rosalind Anderson's] results are perfectly reproducible in my laboratory". He also stated that "This method, ASTM-E981, has been used all over the world and I have never received a complaint from a user of it that the method itself produces neurotoxic nervous system effects".<sup>43</sup>

The Anderson results on carpet emissions were published in the *Journal of Nutritional and Environmental Medicine* in 1995.<sup>44</sup>

#### IMPACT ON CARPET INSTALLERS' HEALTH

Anecdotal evidence also points to medical problems related to carpet installation. A high incidence of lung cancer has been reported within the industry, in addition to typical reactions to chemicals. These reactions include neurological and respiratory symptoms such as dizziness, forgetfulness, tremors, memory loss, pins and needles and recurring nosebleeds. One worker noted that the process of seaming creates potent fumes. Warnings are given not to inhale these chemicals or burn them, but a hot seaming iron is required to melt materials together.<sup>45</sup>

Carpet installers who have been tested have shown high levels of chemicals in their blood, resulting in nerve damage and cognitive impairment. Studies have found that there is a higher instance of leukaemia and testicular cancer in carpet workers than in control groups. Other studies have found that carpet-layers are at risk of oral and pharyngeal cancer. Those exposed to solvents have been found to be at an increased risk of neuropsychiatric disorders. A Russian study found that during "animal experiments simulating working conditions, the central nervous system is the most sensitive".<sup>46</sup>

**Older carpets can be worse than new ones, because they act as a sink for dirt and chemicals.**

#### HAZARDS OF OLDER CARPET

Unfortunately, just because a carpet is no longer new, this does not mean it is healthy! Older carpets can be worse than new ones, because they act as a sink for dirt and chemicals.

#### Dust, Dust Mites and Damp

Older carpets and worn carpets are a great repository for deep dust.<sup>47</sup> Environmental engineer John Roberts commented that "If truckloads of dust with the same concentration of toxic chemicals as is found in most carpets

were deposited outside, these locations would be considered hazardous waste dumps".<sup>48</sup>

Dust mites thrive in carpet; they survive on flakes of dead skin and leave excrement that is extremely allergenic.<sup>49</sup> A study commissioned by the Healthy Flooring Network and undertaken by Dr Jill Warner, Senior Lecturer in Allergy and Immunology at the University of Southampton, England, found that carpets contained more dust mites than did bedding. It was also noted that carpets "are actually the biggest reservoir for allergy-causing dust mite and pet allergens in the home".<sup>50</sup>

Another UK study in 2000 revealed that three out of eight carpet samples were shown to contain notable levels of permethrin, used to control dust mites. Earlier German research discovered that "elevated levels of permethrin found in domestic homes were largely due to the presence of treated carpets". Permethrin has been shown to have neurotoxic effects on laboratory animals—but if it permeates carpet fibres, dust mites continue to survive regardless of the chemical.<sup>51</sup>

Mould and mildew cannot be removed if a carpet has been wet for more than a day or two. In this instance, the carpet and padding or underlay is rendered useless and must be replaced, as cleaning will not dislodge the fungal growth.<sup>52</sup> The US EPA's advice is to replace carpet if it has been damp for more than 48 hours.<sup>53</sup>

#### Asthma and Allergens

Asthma attacks can be triggered by dust mite allergens.<sup>54</sup> The Healthy Flooring Network reported that Dr Jill Warner's study

"highlights fitted carpets as playing a major role in the alarming rise of asthma and allergies". British households have the most carpeting at over 90%, and also the highest rate of asthma and allergies in the world.<sup>55</sup> Another UK study, conducted in 2001, revealed that, along with undertaking appropriate cleaning measures, removing carpet from infants' bedrooms reduced asthma and allergies in children at risk.<sup>56</sup>

The Healthy Flooring Network also reported that the Carpet Foundation in the UK was taken to the Advertising Standards Authority after making false claims in an advertisement. The Carpet Foundation was prevented from making further claims "implying that it was an undisputed scientific fact that there was no link between carpet and asthma".<sup>57</sup>

### Pesticides and Volatile Organic Compounds

Any chemical walked in on shoes or brought inside on wheels of prams or bicycles and in the paws of animals can become trapped in carpet. Tests on dogs' paws have detected very high levels of pesticide residues.<sup>58</sup> An alarming statistic from the US EPA states that "80% of most people's exposure to pesticides occurs indoors". Chemicals may also drift in through open windows or come in on clothes and be absorbed by carpet.<sup>59</sup> Pesticides tracked inside will not be broken down, due to lack of sunlight. Vacuum cleaning can "reduce the accumulation of such contaminants, but not even hot-water extraction can eliminate them all".<sup>60</sup> In the United States, pesticides and VOCs are estimated to cause up to 3,000 cases of cancer per year.<sup>61</sup>

Robert Lewis undertook research for the US EPA and discovered that plush carpet samples aged between 10 and 33 years contained very high levels of chemicals. Numerous carpets had accumulated pesticides used in insect sprays. Pesticide levels showed up many times higher than any amount of insect spray that would be applied in a single use.<sup>62</sup>

It is also important to note that when a chemical is outlawed, this doesn't mean it will not be found in home and outdoor environments any longer. Banned in the US in 1972, DDT was found in 1992 and 1993 in carpets of 90 of 362 homes studied by Jonathan D. Buckley of the University of Southern California and David E. Camann of the Southwest Research Institute.<sup>63</sup>

Scotchgard™ is a product used on carpets as a stain inhibitor. Until 2000, the formula contained the chemical perfluoro-octanyl sulphate (PFOS). Manufacturer 3M removed PFOS from the formula in 2000, as the toxin had been found in high levels in wildlife tissue samples, particularly in urban areas. The chemical's full effects are unknown but, under testing, high levels caused reproductive problems in rats.<sup>64</sup>

VOC adsorption (gathering of a substance on a surface in a condensed layer) can occur on carpet fibres, and the chemicals released at a much later date. For example, curing paint can off-gas VOCs which settle in carpet.<sup>65</sup> This can also be true of household pesticides such as those used in impregnated strips, bombs and foggers, and also substances such as the extremely hazardous formaldehyde offgassed from resins and subflooring materials<sup>66</sup> as well as pressed wood products and glues.<sup>67</sup> Toxic deposits can also remain after cleaning with certain products.<sup>68</sup>

According to the US EPA, VOCs occur at levels two to five times higher indoors than outdoors and 1,000 times higher when occurrences like renovations are taking place.<sup>69</sup> Last year, *New Scientist* reported that studies undertaken on adults in the late 1980s found exposure to toxic pollutants 10 to 50 times higher indoors than outdoors.<sup>70</sup> Strong associations have been made between gardening pesticides and "hyperactivity, leukaemia and damage to the blood/brain barrier in children, and with birth defects in newborns due to maternal exposure".<sup>71</sup> Dwellings with many soft or textured surfaces were named in a European study as collecting more airborne benzene than homes without these types of surfaces. Airborne benzene is implicated as a cause of leukaemia.<sup>72</sup> Even small amounts of VOCs can have effects such as headaches, nausea and respiratory problems on allergy sufferers, people with lung conditions and the elderly.<sup>73</sup>

Carpet shampoos, containing ammonia and perfumes, can be toxic. The known carcinogen perchloroethylene may be found in carpet cleaner.<sup>74</sup> Some cleaners contain solvents, often petroleum-based, which emit VOCs.<sup>75</sup> Other hazardous chemicals such as toluene and benzene have been found in fibre cleaners.<sup>76</sup> Carpet deodorisers are also cause for concern, as they degrade very slowly. Some contain musk-xylene, which has caused tumours in mice, or musk-ambrette, a neurotoxin to animals.<sup>77</sup>

#### Endnotes

1. Renner, Rebecca, Curse This House, *New Scientist*, no. 2289, 5 May 2001, p. 36.
2. US Environmental Protection Agency, Indoor Health Pollution: An Introduction for Health Professionals, <http://www.epa.gov/iaq/pubs/hpguide.html#faq6>, last updated February 19, 2002.
3. Antibody Assay Laboratories, Immunologic Tests in Illness from New Carpet Exposure: A Form of Indoor Pollution, <http://www.aal.xohost.com/capetdoc.htm>, last modified November 13, 1997.
4. US Environmental Protection Agency, Alphabetical Order List of Extremely Hazardous Substances (Section 302 of EPCRA), <http://www.epa.gov/swercepp/ehs/ehsalph.html>, last updated February 4, 1999.
5. US Environmental Protection Agency, Indoor Air – Formaldehyde, <http://www.epa.gov/iaq/formalde.html>, last updated June 13, 2002.
6. Duehring, Cindy, Carpet Concerns – Part Two: Carpet Installers Speak Out as the Medical Evidence Mounts, <http://www.holisticmed.com/carpet/tc2.txt>.
7. US Environmental Protection Agency, Technology Transfer Network, Air Toxics website, Ethylbenzene, <http://www.epa.gov/ttn/atw/hlthef/ethylben.html>, last updated June 14, 2002.
8. Washington Toxics Coalition, Protecting Children from Toxic Exposures: Maintain Good Indoor Air Quality, <http://www.watoxics.org/tkiaq.htm>.
9. Duehring, op. cit.
10. *ibid.*
11. *ibid.*
12. Washington Toxics Coalition, Protecting Children..., op. cit.
13. Duehring, op. cit.
14. Citizens for a Safe Learning Environment, Carpets in Schools?, by K. Robinson, <http://www.chebucto.ns.ca/Education/CASLE/carpet.html>.
15. Duehring, op. cit.
16. *ibid.*
17. *ibid.*
18. BuildingGreen.com, Environmental Building News, Carpeting, Indoor Air Quality and the Environment, 2001–2002, <http://www.buildinggreen.com/features/crpt/carpets.htm>.
19. *ibid.*
20. Antibody Assay Laboratories, op. cit.
21. Environmental News Network, Piling It On, by Judy Waytiuk, 1997, <http://www.enr.com/news/enr-stories/1997/07/070997/feature.asp>.
22. BuildingGreen.com, op. cit.
23. *ibid.*
24. US EPA, Ethylbenzene, op. cit.
25. BuildingGreen.com, op. cit.
26. *ibid.*
27. US Environmental Protection Agency, Organic Gases (Volatile Organic Compounds – VOCs), <http://www.epa.gov/iaq/voc.html>.
28. BuildingGreen.com, op. cit.
29. *Pesticides News*, Pests in the home fact sheet – issue no. 11, Carpets – toxic accumulation, no. 50, December 2000.
30. Healthy Flooring Network, Poison Underfoot, 2001, <http://www.healthyflooring.org/reports.html>.
31. London Hazards Centre, Chemical Hazards Handbook – Multiple Chemical Sensitivity,

## Lead and Other Heavy Metals

Lead is a very major concern with carpet acting as a sink. John Roberts (also known as Dr Dust) tested the lead level when his daughter moved house. It was 7,800 micrograms per square metre, while the US EPA's safety threshold is a maximum of 434 micrograms per square metre.<sup>78</sup> Roberts says that any typical household dust sample would cause concern if tested, as it would contain high concentrations of heavy metals, including lead.<sup>79</sup> Plush and shag carpets are more problematic than flat carpets, as they are prone to collecting more toxic dust.<sup>80</sup>

The US EPA advises that lead poisoning symptoms in adults include gastrointestinal discomfort, constipation, anorexia, nausea, fatigue, weakness, personality changes, headache, hearing loss, tremor and lack of coordination. In infants and small children, symptoms include irritability, abdominal pain, ataxia (loss of muscle coordination, especially at the extremities), seizures, loss of consciousness, chronic learning deficits, hyperactivity and reduced attention span.<sup>81</sup> The Environmental News Network also reported that lead causes "kidney damage, high blood pressure, disrupted blood cell production and reproductive problems".<sup>82</sup>

Petrol/gasoline has been regulated in many countries since the 1980s but lead is still in the soil, especially near roads, and may either come inside onto the carpet via shoes or drift in through windows and doors. The American Academy of Pediatrics estimates that "three to four million children in the US under age six have blood lead levels that could cause impaired development, and an additional 400,000 fetuses are at similar risk".<sup>83</sup>

Infants are particularly vulnerable to ingesting contaminated dust in carpet because they spend so much time on the floor.<sup>84</sup> One explanation as to why children and babies are at such a high risk is that they have a higher rate of metabolism than adults and their organs are still developing. Relative to adults, they inhale 23 times as much air.<sup>85</sup> Breastfed babies are at an even higher risk, as the toxins come through their mothers' milk, but Roberts emphasises that "the advantages of breastfeeding outweigh the risks from these pollutants".<sup>86</sup> However, carpet dust from areas where toddlers play has been named as the best indicator of their likely blood lead level.<sup>87</sup>

## Research into Carpet's Negative Health Effects

A controlled study of 30 female subjects indicated that the negative effects of carpet are very real. The women undertook various tasks including logical reasoning, typing and addition tests. During one round of testing, a 20-year-old carpet was concealed on racks behind a screen near the subjects. Data revealed that when the carpet was present, test scores were lower. Without the carpet, 6.5% more words were typed with 5% fewer errors. Furthermore, the subjects scored 3–4% higher on the addition and logical reasoning tests. When the carpet was present, headaches were also reported.<sup>88</sup>

A Stanford University study of children at play has implications for carpet, as it brought to light that in a 10-hour period the children spent six hours in contact with some surface.<sup>89</sup>

Dr Dust believes that phasing out emissions is necessary because infants are not as well equipped as adults to deal with toxins, as their immune systems are not fully developed. He cites the long-term benefit of health cost savings as another incentive for this action.<sup>90</sup>

## ENVIRONMENTAL PROBLEMS

Environmental concerns related to carpets are plentiful.

In the UK, environmental quality standards were exceeded many times in 1997. Water in the North East and Midlands regions was found to have high levels of chemicals used in moth-proofing.<sup>91</sup>

Carpet dyes pollute waterways, and showroom carpet samples and scraps create unwanted waste. Carpet is energy intensive to produce, and old carpets being replaced are generally put into landfills. However, some companies are looking at ways to recycle, and trials have been undertaken by Shaw Industries, Inc. on using carpet as a reinforcement in concrete.<sup>92</sup>

The average carpet's life span, whether in commercial or residential use, is eight years. Consequently, in a Canadian study in the early 1990s, carpet was named as the flooring creating the most environmental impact. A Dutch study had the same findings but specified nylon carpet in its results.<sup>93</sup>

The US EPA acknowledges that there are obstacles in carpet recycling, as there is no infrastructure set up to cope with it.<sup>94</sup>

<http://www.lhc.org.uk/members/pubs/books/chem/chebdmaa.htm>.

32. US Environmental Protection Agency, Indoor Air Pollution: An Introduction for Health Professionals,

<http://www.epa.gov/iaq/pubs/hpguide.html#faq6>, last updated February 19, 2002.

33. London Hazards Centre, op. cit.

34. Chemical Injury Information Network, The Cindy Duehring MCS Research Fund, <http://www.ciin.org/fund.htm>.

35. Duehring, Cindy, Carpet Concerns – Part One: EPA Stalls and Industry Hedges While Consumers Remain at Risk,

<http://www.holisticmed.com/carpet/tc1.txt>.

36. *ibid.*

37. *ibid.*

38. Cornell University, Emissions from New Carpets are Not a Health Problem, Cornell Study Finds, Science News Media Release, March 1995,

<http://www.news.cornell.edu/science/Mar95/st.carpet.html>.

39. Duehring, Carpet Concerns – Part 2, op. cit.

40. Anderson, Rosalind, PhD, Carpet Chemical

Emission – Carpets, 1995,

<http://www.airbrains.org/carpetchemical.htm>.

41. BuildingGreen.com, op. cit.

42. BuildingGreen.com, op. cit.

43. Duehring, Part 1, op. cit.

44. Anderson, Rosalind, PhD, Toxic emissions from carpets, *Journal of Nutritional and Environmental Medicine* 1995, 5:375-386.

45. Duehring, op. cit.

46. *ibid.*

47. Roberts, John, Protection from the Toxic Insult of Dust, *Ecobuilding Times*, vol. 6, no. 1, 1999, <http://www.ecobuilding.org/lib/ebt/1999/roberts.htm>.

48. Airbrains.org, Carpet Toxins, Wall to Wall, <http://www.airbrains.org/CARPETtoxins.htm>.

49. BuildingGreen.com, op. cit.

50. Healthy Flooring Network, Carpets Can Damage Your Health, 2000, <http://www.healthyflooring.org/reports.html>.

51. Healthy Flooring Network, Poison Underfoot, op. cit.

52. BuildingGreen.com, op. cit.

53. Roberts, op. cit.

54. Washington Toxics Coalition, Carpeting and

Children's Health: How Flooring Decisions Can Affect Your Home's Indoor Air Quality, <http://www.watoxics.org/tkcarpet.htm>.

55. Healthy Flooring Network, Carpets Can Damage..., op. cit.

56. Healthy Flooring Network, Clamour Against Carpets Grows Stronger, August 1, 2001, <http://www.healthyflooring.org/pressreleases.html>.

57. *ibid.*

58. Ott, Wayne R. and John W. Roberts, Everyday Exposure to Toxic Pollutants, *Scientific American*, February 1998, <http://www.sciam.com/1998/0298issue/0298ott.html>.

59. *Pesticides News*, op. cit.

60. BuildingGreen.com, op. cit.

61. Ott and Roberts, op. cit.

62. Renner, op. cit.

63. Ott and Roberts, op. cit.

64. Environmental News Network, Scotchgard Sticks in the Environment, Study Finds, by Margot Higgins, April 11, 2001, [http://www.enm.com/news/enm-stories/2001/04/04112001/pfos\\_42961.asp](http://www.enm.com/news/enm-stories/2001/04/04112001/pfos_42961.asp).

## ALTERNATIVES AND SOLUTIONS

As far as dust is concerned, *no* carpet is the only real solution. Dwellings with bare floors and a few rugs contain around a tenth of the dust found in a house with wall-to-wall carpet.<sup>95</sup> The best option for MCS sufferers would seem to be plain ceramic tiles.<sup>96</sup>

However, there are ways to reduce carpet-related chemical exposure. The use of carpet glues and adhesives can be avoided or reduced in some situations. Woven carpets necessitate much less adhesive backing because they are more stable than tufted carpets. Another way of avoiding adhesives is to use mechanical fastening. A patented hook and loop system utilises fabric and hooks taped to the floor and can be used on seams and room perimeters.<sup>97</sup>

Woollen carpet is often cited as a suitable floor covering, as it is naturally flame resistant and very durable. According to wool industry-funded research, VOCs such as formaldehyde and nitrogen oxide that become trapped in fibres will not be released in woollen carpets, as they chemically bond to the fibres. However, this claim has not been verified.<sup>98</sup>

## CARPET MAINTENANCE

*New Scientist* reported that according to Dr Dust (John Roberts), excessive vacuum cleaning is necessary to remove the build-up of toxic dust in carpet. He suggests vacuuming carpet near the house entrance 25 times per week, high traffic areas 16 times and the remaining carpet eight times. Apparently this will remove a good deal of the deep dust, after which time half of the initial vacuuming will be necessary each week to keep the amount of dust to a minimum.<sup>99</sup>

Vacuuming can cause trapped dust to become airborne, so it is essential to use a good-quality vacuum cleaner to remove it effectively. Vacuum cleaners with high efficiency particulate air

(HEPA) filters are the most efficient.<sup>100</sup> These can trap particles of 0.3 microns in size.<sup>101</sup> A power head can collect three to six times more dust than a regular vacuum cleaner head can. Some vacuum cleaners also have a red light that changes to green when it is no longer picking up dust.<sup>102</sup> This cleaning process can take as long as 45 minutes per square metre of old carpet, but the time is reduced substantially once this major task has been undertaken for the first time.<sup>103</sup>

Steam cleaning can also be effective, and if done professionally it can kill fleas, dust mites and some bacteria<sup>104</sup> with minimal environmental impact.

Dr Dust has also found that high-quality doormats can "reduce the amount of lead in a typical carpet by a factor of six"<sup>105</sup> if feet are wiped twice before entering a dwelling. Taking shoes off is also very effective in keeping pesticides and lead out of carpet.

## CONCLUSION: TREADING CAREFULLY FOR OUR HEALTH

Chemicals contained in new carpet, particularly if it is synthetic, are toxic and can be of concern to many people, particularly those with multiple chemical sensitivity. The carpet industry insists this type of floor covering is a clean option, but studies have shown otherwise. VOCs are emitted from both new and old carpet, with old carpet acting as a sink for dust containing contaminants such as lead.

Carpet is not a good option for asthma and allergy sufferers, and installers have reported ill health related to their trade. Studies have shown old carpet can also have immediate negative effects on health and productivity. Keeping carpet clean to acceptable levels for good health creates a substantial workload, and carpet is not very environmentally friendly.

The long-term health effects of carpet are not clear, but what *is* clear is that there are major concerns related to having a carpeted home, school or place of business.

**Dwellings with bare floors and a few rugs contain around a tenth of the dust found in a house with wall-to-wall carpet.**

65. BuildingGreen.com, op. cit.

66. US EPA, Indoor Air Pollution, op. cit.

67. US EPA, Indoor Air – Formaldehyde, op. cit.

68. BuildingGreen.com, op. cit.

69. US EPA, Organic Gases, op. cit.

70. Renner, op. cit.

71. True Health, Supreme Health, Carpet Health Hazard, 1998–2002,

<http://www.truehealth.org/ahealt04.html>.

72. Airbrains.org, op.cit.

73. Vermont Department of Health, An Air Quality Fact Sheet on Carpet, [http://www.state.vt.us/health/\\_hp/airquality/carpet/carpet.htm](http://www.state.vt.us/health/_hp/airquality/carpet/carpet.htm).

74. Total Environment Centre, Sydney, Australia, Frequently Asked Questions, I need to clean my carpet – what would you recommend?,

[http://www.tec.nccnsw.org.au/member/tec/projects/tcye/faq/Household/faq\\_101.html](http://www.tec.nccnsw.org.au/member/tec/projects/tcye/faq/Household/faq_101.html), last modified March 27, 1998.

75. Vermont Department of Health, op. cit.

76. Citizens for a Safe Learning Environment, Carpets in Schools?, op. cit.

77. Total Environment Centre, Frequently Asked Questions, I am becoming increasingly intolerant....

[http://www.tec.nccnsw.org.au/member/tec/projects/tcye/faq/Household/faq\\_140.html](http://www.tec.nccnsw.org.au/member/tec/projects/tcye/faq/Household/faq_140.html), last modified March 27, 1998.

78. Renner, op. cit.

79. *ibid.*

80. Ott and Roberts, *Everyday Exposure....*, op. cit.

81. US EPA, Indoor Air Pollution, op. cit.

82. Environmental News Network, Close to Home: The 10 Most Dangerous Toxins in Your House, by Claude Morgan, January 14, 1999, [http://www.enn.com/features/1999/01/011499/toxins\\_1139.asp](http://www.enn.com/features/1999/01/011499/toxins_1139.asp).

83. US EPA, Indoor Air Pollution, op. cit.

84. Roberts, Protection, op. cit.

85. Renner, op. cit.

86. Roberts, op. cit.

87. Duehring, Part 2, op. cit.

88. US EPA, Indoor Environments Division, Office of Radiation and Indoor Air, Indoor Air Quality and Student Performance, August 2000, <http://www.epa.gov/iaq/schools/performance.html>.

89. Renner, op. cit.

90. Roberts, op. cit.

91. *Pesticides News*, op. cit.

92. BuildingGreen.com, op. cit.

93. *ibid.*

94. US Environmental Protection Agency, Product Stewardship, Carpet, <http://www.epa.gov/epr/products/carpet.html>, last updated June 19, 2002.

95. Airbrains.org, op. cit.

96. Environmental News Network, Piling It On, op. cit.

97. BuildingGreen.com, op. cit.

98. *ibid.*

99. Renner, op. cit.

100. Vermont Department of Health, op. cit.

101. BuildingGreen.com, op. cit.

102. Renner, op. cit.

103. Roberts, Protection, op. cit.

104. Washington Toxics Coalition, Carpeting and Children's Health, op. cit.

105. Ott and Roberts, op. cit.

### About the Author:

Jenny Hawke has a BA in Communication and is on staff at the NEXUS head office in Australia. She is now relieved to live in a house without carpet.

## THE GEOMETRY OF THE NAKED SINGULARITY

by Carl Hollingsworth and Henry Hallmon © 2001

A profound puzzle has emerged from recent scientific discovery. Dark matter appears to be a common feature—so common that the majority of mass is dark. Dark matter is predicted in the disc of our galaxy and in envelopes around every galaxy. The mystery is: what is it, and why can't we find it? The solution may be right under our nose.

A naked singularity model solves dark matter's mystery with the same rules for a single cell as for a single galaxy. For dark matter, the rules of physics as we know them do not apply. It exists as informational mass in negative space. This solution to dark matter's mystery dramatically changes our understanding of quantum physics and information's physical nature.

### The Naked Singularity Model

We are looking at a new model of physical organisation: a parallel network of conserved information.

Our naked singularity model (see figure 1) identifies two components to physical structure. The two components are separated by individual requirements of existence, yet inseparably linked in every host environment. Unextended component one exists adjacent to extended component two. The two do not interact directly. Instead, interactions occur in frequency space by some sort of phase-coupling phenomenon. Nerve impulse traffic generates the necessary frequency waves for phase-coupling.

We have determined the transport energy source as boundary layer motion. The boundary layer behaviour absorbs all surrounding frequency waves. It then transports the *eigenfrequency* (the sum of absorbed informational frequency) to naked singularity locations at greatest chord height or depth, where it stops. At this point, the delivered eigenfrequency can phase-couple, since it is time locked and polarity matched. We will explore this transport mechanism in depth later.

### Some Predicted Elements

- A naked singularity has slight mass.
- A naked singularity is negative space.
- A naked singularity requires a strongly asymmetric environment.
- Functional asymmetric enclosure is provided by all host forms.
- Such enclosure must approach maximum surface for volume enclosed.
- A naked singularity is time locked.
- Shifts of a naked singularity from one host enclosure to another are wormhole events.
- Wormhole events are time locked.

Naked singularities are interconnected by a time-locked history of host location and wormhole events. These predicted elements paint a strange picture of an adjacent negative space beyond the grasp of our senses.

Similar notions have always captivated human thought. A brief history lesson will help you get the idea.

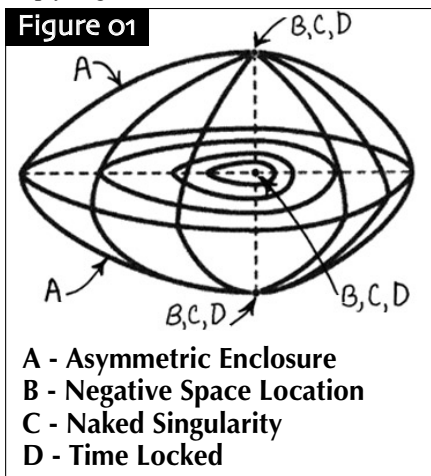

### The Unextended World

The story of the unextended world is an ancient one, with roots stretching back to prehistory. Hermetic science described the unextended as *prime material*. *Prima materia* served as a ghostly template behind the visible shapes of matter. Everything, from mineral to man, contained this very fine, subtle spirit substance. The visible was considered a mirror image of prime material and had no independent existence.

This mind-in-the-body idea pretty much prevailed until the beginnings of Western

science and René Descartes' birth in 1596. Only since Descartes has the material world been broken into two. Matter, the stuff you can see and touch, claims the property of spatial extension. Mind is separate and lacks spatial extension. Interchangeable mind, soul or spirit literally exists in an unextended state without occupying space. Today, this is considered dualist philosophy (the view that both mind and matter are real but separate).

René Descartes is credited with the idea of unextended state. He considered mind and soul the same thing: a spiritual entity unextended in space. The body has extension, while mind does not. Mind's nature is to think, therefore exist. Because mind is independent of the body, it survives bodily death.

Descartes' famous quote—"I think, therefore I am"—first appeared in the 1637 *Discourse on the Method*, in French. (By 1637, Galileo was under house arrest. It was a risky time for new and possibly heretical ideas.) In 1644, the quote appeared in Latin (*Cogito, ergo sum*) as the lead to *Principles of Philosophy*. Here he separated the thinking thing (*res cogitans*) from that which has extension (*res extensa*).

Not just a philosopher, Descartes was mathematically sophisticated. He developed Cartesian coordinate graphs. Calling the square root of negative numbers *imaginary* (a term still in use), he chose not to extend his graphs to the negative—an oversight almost immediately remedied by his contemporaries (see figure 2).

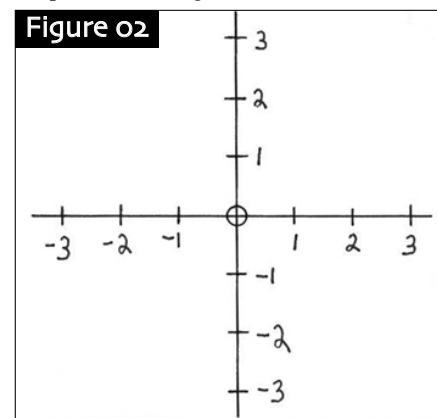

**Figure 03**

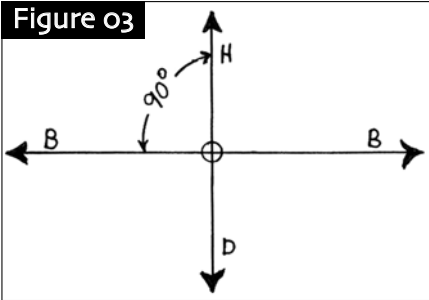

Cartesian graphs have developed into one of the best scientific tools. While mathematical formula is sufficient for precise description, a glance at corresponding graphs clearly shows how change in one quantity influences others. Today, these graphs are widely used in science and industry to represent directional or measured quantities and formulas graphically. For this, Descartes is generally considered the founder of analytical geometry, or at least the first to write about it.

While embracing analytical geometry, science regards Cartesian dualism with horror. How is it that a mind or soul is unextended in space? Where is it? How can it interact with the extended physical host? Such a transaction seems impossible. Surely mind can be a property of the material body without resorting to an imaginary unextended world.

Descartes could never adequately respond to these and other criticisms. He tried, but the needed technology just wasn't there. Today, the tables may have turned. From the archaic viewpoint, astonishing advances in neuroscience, genetics and quantum physics have already answered the "where" and "how" of the unextended world. But we're getting ahead of the story. Let's start at the beginning: the hermetic science of prime material.

## Hermetic Science

*In the centres of form  
The prime material hides  
Informing the host  
That it secretly guides*

For thousands of years, one idea—Hermetic prime material geometry—stood as the foundation of science. A concept that survived civilisations lives on in the popular imagination, yet is rarely presented in its original scientific context. It's strange indeed that an idea once widely understood has become difficult to rediscover.

Let's start the inquiry with the oldest known scientific principle: the First Prime of Universal Order—a point which is the

apices of two right angles measuring height, depth and breadth (see figure 3).

The First Prime explains, with stick figure simplicity, the relationship of prime material to the host form it occupies. Prime location is strictly limited to the apices' point. Height, breadth and depth can be graphed on the shared-centre right angles. Descartes, a student of archaic science, may have based his Cartesian graphs on First Prime graphical representation.

In a letter to Mersenne, Descartes described the equiangular spiral as the secret to the universe. Hermetic geometry employed spirals ranging from equable to equiangular, sometimes in two-dimensional shared-centre spiral planes. Two-dimensional spiral planes were considered the connecting link between three-dimensional host form and one-dimensional prime material. On a First Prime graph, it looks like this (see figure 4):

**Figure 04**

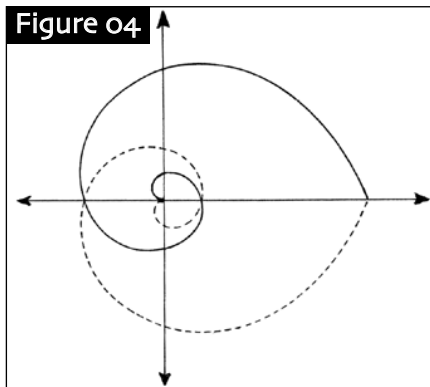

These two-dimensional spiral planes (when viewed from the appropriate cross-section) occur throughout the natural world, but are rarely observed in the Euclidean representations. Most examples occur as conformal distortions.

Hermetic geometry artifacts display a working understanding of conformal distortions—a fairly recent achievement of

**Figure 05**

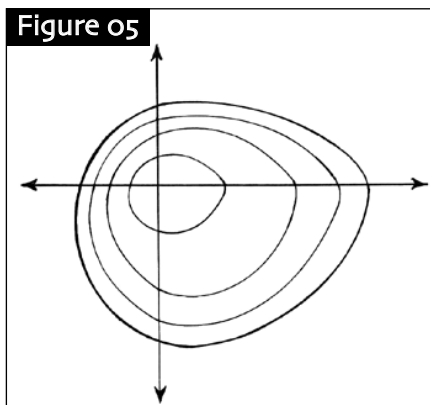

modern science with Riemannian and Lobachevskian geometry. Figure 5 shows a conformal distortion of figure 4.

Hermetic scientists concluded that prime material was a subtle spirit substance, hiding within the myriad forms of the universe by occupying a strictly ordered geometry of locations. Great importance was placed on the golden ratio and the Fibonacci series, both evident in the golden rectangle (see figure 6).

**Figure 06**

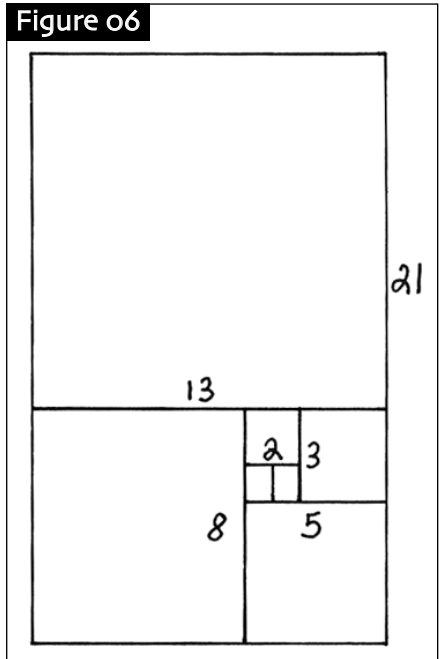

The golden rectangle is a gnomon which regresses to a potential prime location in a gnomonic regression. *Gnomon* is defined as "any figure which suffered no change, save for magnitude". Many figures fit the gnomon definition and golden ratio (see figure 7). Since everything physical generates from central prime material in a gnomonic growth pattern, the material world is considered a network of gnomons without independent existence of their own.

Fascinating, but often cumbersome, technology developed along this line of reasoning, probably peaking by the late Bronze Age. Unfortunately, subsequent civilisations apparently lost the whole understanding, retaining only the sacred geometry symbolism and various mystical practices. By the time of modern scientific development, hermetic geometry had fallen into disrepute, save as fable and superstition.

It's not surprising that prime material awaits rediscovery, and it is clear that the solutions of the past will not answer the questions of the future. The "where",

Figure 07

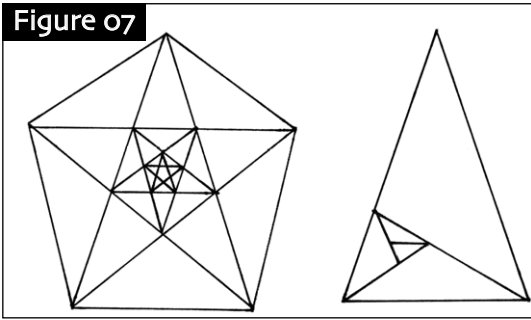

"what" and "how" of an adjacent negative space is an extremely difficult research problem. Only in the last 30 years has science acquired the necessary expertise and technology to investigate the phenomenon.

Neuroscience, for one, has developed the tools and done the research confirming a naked singularity network is possible and even probable. So, next thing, let's plug the problem into recent neuroscience observations and see what comes out.

### The Neuroscience Connection

Hermetic science was self-limiting. A comprehensive understanding of the physical world lay beyond its scope of inquiry. Descartes' dualist approach took a step towards updating the prime material view, but the effort was well ahead of his time. Today, rapid advances in neuroscience suggest a naked singularity model is on the right track. Let's look at some of what is presently known about neuroanatomy.

The central nervous system is constructed of two kinds of cells: the *neuron* and the *glial*. Glial cells support neuron cells. Neuron cells linked together in circuit generate nerve impulse traffic; they have three main components (see figure 8):

- 1 – a cell body containing the *nucleus*;
- 2 – a main output fibre, known as the *axon*;
- 3 – input fibres, known as *dendrites*.

Neuron cells interconnect in synapses, which usually consist of an output axon contacting the input dendrites of another neuron cell. Billions of neuron cells organise into local circuits in this manner. When arranged in parallel layers, local circuit groups are called *cortical regions*. When non-layered, local circuit groups are called *nuclei*. These microscopic local circuits group together, forming pathways visible to the eye. Other non-central nervous system cell groups can selectively join circuit pathways through bundles of axons reaching to every point in the body. The whole deal forms a sort of nerve impulse traffic highway system.

Here is a thumbnail sketch of the nerve impulse. Neuron cells fire a unique electrical current from the cell body down the axon. Each neuron cell tends to talk to a few others close by. Whether or not the next adjacent neuron cell will fire depends on current strength. The basic architecture stays local. Almost any specific brain function can be traced to the group of neuron cells associated with it.

There is nothing haphazard about this mapping. Magnetic resonance imaging (MRI) and positron emission tomography (PET) scanning allow the three-dimensional reconstruction of nerve impulse traffic. During surgery, changes in electrical potential are measured directly on the brain's surface. Polygraphs measure the skin's electrical conductance to identify specific responses. Surgeons are now implanting tiny electrodes deep into patients' brains. The electrodes are internally connected to a battery and pulse generator that is surgically implanted below the collarbone. This powerpack delivers pulses of electricity to interrupt selected nerve impulse traffic for the purpose of controlling severe movement disorders. These and other related results paint a comprehensive picture of the nerve impulse traffic.

Despite impressive technical achievements, memory remains a mystery. Neural patterns function as selective storage and retrieval circuits for memory images. These are representations prompted by an object or previous experience. Location of memory images is not presently accounted for in neuroanatomy. It is known that they do not bind in the circuit! The majority position is that neuroanatomy will be capable of accounting for memory image location in some yet-to-be-discovered way.

This problem is generally known as the *binding* problem. Binding requires some sort of time-locking to account for memory image storage and retrieval. This is where the historical model fits in. Prime material, in an unextended network of central nervous system locations, uniquely and elegantly solves the binding problem. In modern science terminology, we are talking about

negative-space informational mass in a naked singularity network. A naked singularity is different from its "centre of a black hole" cousin. A naked singularity, by definition, is time locked and has slight mass.

Our proposed idea is that naked singularity locations form a time-locked network of memory images. Well-defined neural patterns selectively store and retrieve memory images in a reversible computation process.

Presumably there is a hierarchy of this reversible computation going on. A single host cell would contain a simple naked singularity network. Memory at this level would deal with local concerns of specialised cell function. This time-locked information is available to other networks as required.

At the most complicated level, consciousness is closely linked with the central nervous system. Recent evidence suggests the location of core consciousness as the mid-line area of the central nervous system; specifically, a right-hand and left-hand mirror image across the centreline.

Damage to these sites disrupts core consciousness, while extensive damage that leaves the centreline intact does not. Not surprisingly, this centreline is ancient from an evolutionary perspective; it is present in many non-human species, and matures early in embryonic growth. Many other neuroscience examples support this idea. None proves it conclusively, but the naked singularity model does solve the binding problem and otherwise holds together rather well.

The binding problem is the same for genetics. Let's consider how our model fits there.

### The Genetic Code

Last year, in a rare show of unity, private sector and government-funded researchers jointly declared the Genome Project substantially complete. A linear sequence base has been acquired for the fruit fly, mouse and human. It turns out that the fruit fly has

Figure 08

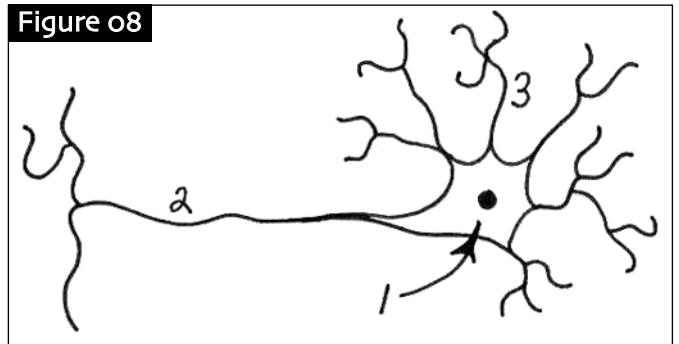

50% of the human genetic code. Don't think this makes the fruit fly half as complex as a person. Each human gene can make three or four different protein patterns, plus variations. A fruit fly gene is limited to one protein configuration and few variations.

The whole linear sequence—100,000 to 120,000 genes—is in every cell in your body. Out of these, about 30,000 are human genes. They are scattered here and there in the sequence. Nobody has actually seen a gene. Genetic information first appears as DNA. The DNA tells RNA what proteins to build. The RNA assembles protein patterns from amino acids. Three types of RNA build protein patterns from 20 different amino acids. Each protein folds into its own unique shape. They look like fantastic, two-dimensional origami art.

The next big genetics project is mapping the possible protein shapes. This counterpart to the Genome Project will be called the Proteo. Success seems likely, since the chemical machinery of protein synthesis is so well understood. Check out an up-to-date science text for the details.

Think of DNA as the architect, RNA as the workers, amino acids as lumber, and protein patterns as the framing superstructure. Take note that the one-dimensional gene is missing from the chemical explanation. Genetic information first appears as DNA, but that is not where it is stored. It's the same binding problem as for memory.

Binding requires time-locking to account for information storage and retrieval. Genetic information binds with the one-dimensional gene. It is supplied to the chemical process in a computer code. This code is written in three-letter words. The alphabet for DNA is A, C, G and T; each letter corresponds to the bases adenine, cytosine, guanine and thymine. RNA is the same, except U (uracil) replaces T (thymine). Like familiar binary computer code, there are no spaces between commands. For example, AUGCGG is an RNA code because it contains the letter U. This message is two command words, each the mandatory three letters long. This is the language between genes and their DNA-RNA replicating machinery.

You can see where we are going with this. One-dimensional genes represent the naked singularity network for carbon-based life. Cell wall and nucleus membranes fulfill the asymmetric enclosure requirement. But we're getting ahead of the story again.

Let's see why quantum physics needs adjacent negative space.

## The Problem with Physics

Physics is regarded as the measuring rod of reality, but there are a few problems. Astrophysics knows that dark matter exists, yet has no clue what it is. The same goes for dark energy. The inquiry is concentrated on black holes and dark envelopes around galaxies. It is assumed that the dark matter is out there because no one has detected any locally.

The quantum physics problem is at the subatomic level. Everything adds up nicely, but nobody believes that the results apply to the real world. Particles appear out of nothing, then disappear. They exist in many places at once, while behaving like both waves and particles. These and other quantum mechanics results are not in doubt. In the 101 years since Max Planck came up with the idea, it has proven the most accurate scientific theory ever developed. The catch is, it only applies to the subatomic world.

You can see the problem. Modern physics has given up on measuring reality. Gravity works, so there is a bunch of dark matter at the big scale. Quantum mechanics works, but only at the small scale. This leaves Newton's mechanics, modified by Einstein. This works without including modern results.

Adding to the confusion is the *many worlds interpretation* (MWI) of quantum weirdness. The conservative version goes like this. When a quantum measurement is made, the universe splits into two or more possible futures. The extra futures are considered abstract mathematical constructs, with the real future being the one we are in. This is consistent with quantum mechanics if you stay at the subatomic level. The radical view thinks all the parallel futures are literally real. Adherents feel this brings quantum observations into the familiar world. The conservative camp figures the literal interpretation isn't worth the metaphysical baggage.

Quantum paradox is a popular theme these days. A good bookstore has several shelves of books on the subject. Parallel worlds and black holes are favourite topics; and if you check carefully, a naked singularity is occasionally mentioned. Our naked singularity model appears to solve quantum paradox better than the others. It is at least in conceptual agreement with quantum and astrophysics observations, while applying one model to all scales. As the old saying goes, time will tell.

That's about enough history and science

background to help you get the idea. Let's see what we can say about the naked singularity model now.

## Our Naked Singularity Model Again

René Descartes broke the world in two by separating mind from that which has extension. It turns out he was right. Our model suggests unextended informational mass at time-locked locations, with boundary behaviour as its messenger mechanism.

Let's look at boundary behaviour on a flow diagram (see figure 9). Note that it depicts an idealised laminar flow and boundary layer motion. A natural fluid-form interaction is rarely this perfect.

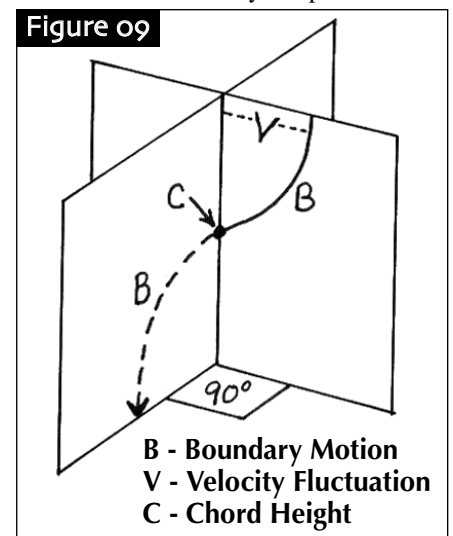

Laminar flow develops the most organised boundary motion, but all flows on a surface generate some boundary behaviour. When laminar flow occurs adjacent to a strongly asymmetric surface, the boundary motion moves at right angles to the parent flow and always in the direction of greatest chord height on the surface.

This boundary behaviour absorbs amplitude frequency from surrounding frequency waves. In this manner, available informational waves bind in the boundary flow as amplified velocity fluctuations. We call the sum of absorbed informational frequency the *eigenfrequency*. Boundary motion carries the eigenfrequency to surface point at greatest chord height, where it stops. At this point, the delivered eigenfrequency can phase-couple, since it is temporarily time locked and polarity matched with a naked singularity location. Information in the eigenfrequency is now informational mass at rest potential in negative space. This is the information messenger mechanism (see figure 10). The simplest

physical structure has these fluid-form interaction features. The most complex has the same features regardless of the complicated detail.

## Elements of the Model

Laminar flow rarely stays stable for long. Velocity and pressures will vary. The associated surface can deform or change aspect to velocity. Often the main contributor to laminar breakdown is the amplified messenger eigenfrequency. The more and stronger the frequency waves absorbed, the quicker the boundary layer velocity fluctuations trip the laminar flow to turbulent flow.

We can say that laminar fluid-form interactions are nature's method for storage and retrieval of informational mass.

Let's break it down into elements:

- Informational waves absorbed into boundary layer.
- Boundary carried as velocity fluctuations to naked singularity location.
- Stops briefly, allowing time-locked polarity matching.
- Transitions to negative space as informational mass at rest potential state.
- Reverses process for informational mass retrieval.
- Boundary breaks up, releasing discrete informational frequencies into flow medium.

Figure 10

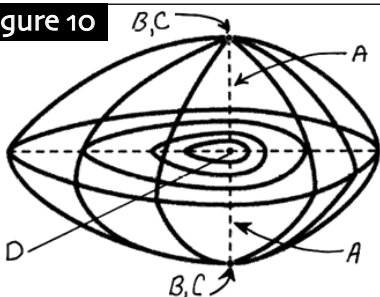

- A - Polarity
- B - Phase-Couple Point
- C - Chord Height
- D - Informational Mass

We can go on with this, but it is just tweaking the same process into different situations. Let's review how our story points fit the model.

## • Hermetic Science

With modern tools in hand, it is easy to disregard the old hermetic scientists, but they were right about the gnostic geometry. Natural morphology does reduce to two-dimensional spiral-based planes and associated enclosures. They knew exactly where

their prime material was located (see figure 11). Note: see D'Arcy Thompson's *On Growth and Form* (Cambridge University Press, 1917) on conformal equivalents.

Figure 11

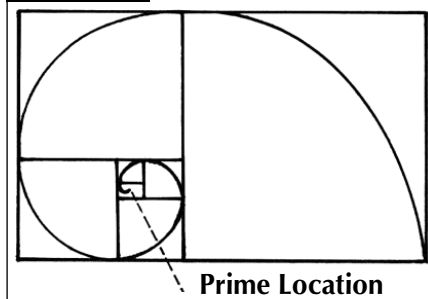

## • Neuroscience

Neuroscience has tracked nerve impulse traffic to specific and localised function. It defines time-locked binding as memory images stored, then retrieved intact years or decades later. This is a crucial element in our model's predictions. Neuroscience is right in that nerve impulse traffic stores short-term memory in frequency space. Our model agrees that information is in frequency waves until delivered by a boundary carrier. It is informational mass only at rest potential state.

## • Genetics

The binding problem is the same here. Genetics research has unravelled the genetic code. Genes are one-dimensional and scattered in less than 2% of the DNA string. DNA and RNA use a chemical alphabet to spell out natural form. Our model suggests the gene is naked singularity core memory until retrieved in the DNA-RNA protein cycle. It is not clear that boundary carrier elements play a direct role in storage and retrieval of genetic information. We think a specialised mechanism is at play in the double helix environment.

## • Physics

We have decades-old calculations in front of us as we write.

Richard Wayte, of the Imperial College, London, describes gravity in terms of *mass loss transfer*. This idea uniquely fits our model and has dramatic implications. It was refused consideration for lack of a suitable messenger particle function to consummate the transfer. High-energy physics needs to lose the preconceived notion of messenger particle function and broaden its approach to delivery mechanisms.

Astrophysics is doing better. It has found

dark matter's footprint with sophisticated gravity lensing. The same results predict envelope enclosure surrounding galaxies. Our model requires just such a strong asymmetric enclosure. A galaxy worth of conserved informational mass will help balance the missing-mass ledger.

## • Wormhole Events

This covers our model pretty well, except for transitions from one host location to another and the history of transitions. We wouldn't mind skipping wormhole events and their sum of histories; the metaphysical baggage is a load. It is, however, a clearly predicted element of our model. Let's pass the Hollywood wormhole illustration and stick to the elements.

Here are the transition elements:

- Shifts of informational mass from one host location to another are wormhole events.
- Wormhole events are time locked.
- Naked singularities are interconnected by a time-locked history of wormhole events.

Our model predicts a time-locked sum of histories interconnecting everything forever. This conclusion assumes informational mass at rest potential as the transitional state. Our research indicates this is probably true. It further assumes a 100% success rate for wormhole events. This seems less likely. A conserved sum of histories is a definite maybe.

## Towards Applied Research

Our basic research is substantially complete. C. E. K. Mees, former director of Eastman Kodak Laboratories, defined *basic research* as "the examination of materials and phenomena to discover fundamental properties, relationships and trends". Mees went on to define *applied research* as "basic research combined with existing technology to yield new technology".

We are moving on to applied research and we urge the reader to do the same. It has become evident that numerous applied research applications will be productive. The trick is to take what you know, insert the appropriate model elements and see what clicks.

## Editor's Note:

Henry Hallmon and Carl Hollingsworth collaborated on Naked Singularity Geometry in 2001. They can be contacted c/- Gaspin' Air Graphics, PO Box 605, DeLand, Florida, 32721-0605, USA, tel (386) 985 5695, email hhallmon@aol.com.



# THE DOTTO RING

## A HEALING, AGE-REVERSAL DEVICE

**Dr Gianni Dotto  
applied his  
understanding of  
DNA to his Ring  
device, which acted  
as an inductive coil  
to recharge the cells  
to their correct  
energy level and  
promote longevity.**

**Part 2 of 2**

**by Dr Gianni Dotto © 1972**

Notes by  
Jerry Decker of KeelyNet

From the KeelyNet website at:  
[http://www.keelynet.com/  
biology/dotto.htm](http://www.keelynet.com/biology/dotto.htm)

*Editor's Note: This edition we continue the 1972 paper by Dr Gianni Dotto on his Ring device. Commentary is provided at the end of the paper by Jerry Decker, who has posted the complete text and some diagrams on the KeelyNet website (at <http://www.keelynet.com/biology/dotto.htm>). Note that several mentions are made to animal experiments. NEXUS does not agree with the practices of animal experimentation and vivisection, but we also don't want to censor the articles we publish.*

### THE AGEING PROCESS

**T**o understand the human ageing process, let's now examine the structure and the function of the DNA. Imagine a flexible ladder one metre (39 inches) long, composed of six billion steps. Each step has the form of two capital Ts facing each other. The horizontal line of the T has 70% of its length made of sugar and 30% of phosphate. The vertical line is of a different composition: adenine or guanine, or thymine or cytosine.

At the vertical ends of the T, there are atoms of hydrogen. (The hydrogen, first element in the atomic chart, is composed of one proton and one electron.) At the end of the phosphate rod, the orbital electrons spin clockwise. At the end of the sugar rod, the orbital electrons spin counter-clockwise. In the hydrogen atoms at the end of adenine and thymine, the electrons spin clockwise; and in the hydrogen atoms at the end of guanine and cytosine, they spin counterclockwise. This type of T is called a *base* or *nucleotide*.

The DNA is then formed by 12 billion nucleotides facing each other and connected in a straight line to form the double helix—deoxyribonucleic acid, or DNA. This is the genetic code, and every one of the 6.3 trillion cells of the human body has at least one. To form a new cell, the DNA must repeat itself. This is accomplished by splitting the ladder along the middle of the step and reforming two DNAs absolutely identical and in the same sequence. To form two DNAs, another 12 billion nucleotides are necessary.

Inside the cell nucleus there are constantly at least eight different types of virus: four RNA types (negative charge), and four DNA types (positive charge). Every pair of virus (one RNA and one DNA type) attracts each other to form a bipole. They do so, first, to protect themselves against any external magnetic disturbance, and, second, to accumulate energy in the following manner... Inactive viruses are crystal forms, but in active status, such as inside the cell nucleus, they reveal one RNA or DNA core covered with protein. Of course, even in active status they still maintain all the properties of a crystal, and as a crystal they are very sensitive to the high sound frequency.

Under sound frequency up to five megacycles, the two viruses continuously strain each other and produce energy due to the piezoelectric effect (the same principle is used in the energy conversion effect of the supersonic generator). In the ultra-high sound frequency over five megacycles, an isolated inactive virus can be excited to alter the transition temperatures or Curie point and disintegrate (Ruben). The human DNA (like a Yagi antenna, one metre long) is tuned to any radio emission between 375 and 385 megacycles.

Furthermore, the DNA is under the constant influence of charged ions travelling through the nervous system and acting as a modulation frequency. The combined action of the two physical phenomena force the DNA to emit a high-frequency sound in the range of 1.9–2.0 megacycles in order to detect, by returning echo, what type of protein is missing in the cell. These sound frequencies are not only necessary to the DNA in scanning the type of RNA to produce, but they also maintain active the virus in bipole form by means of the strain effect.

To control the energy level from the piezoelectric effect, the RNA-type virus covers itself with phosphate and the DNA-type virus with sugar. In forming this special type of coating, the virus—like any living organism—produces waste. These wastes are accumulated in the centre of the rod just formed and will be called adenine, guanine, thymine or cytosine according to the type of virus in the bipole. The process to make the coating is accomplished at the expense of the electrical charge accumulated by the piezoelectric effect. At the end of the charge, to remain active the group of viruses removes the coating that now is in the form of a capital T and exposes itself to the high-frequency sound produced by the DNA, and the process starts all over again.

Due to the described phenomena, the DNA has always enough bases available to produce RNA strains and to reproduce itself.

Now, let's go back to the flexible ladder composed of six billion steps. Suppose we twist this strange ladder so many times as to have only a few steps for every turn of the coil so formed (these steps are called *base pairs per turn*). Since every base has different polarity according to the code formed by past generations, the DNA can be compared to the multi-polarity rotor of an alternator. In the alternator, the speed is inversely proportional to the number of poles and the output power is directly proportional to the energy applied.

At every electrical impulse flowing through the nervous system, the DNA moves back and forth as many degrees as one base is separated from the next one. The more base pairs per turn, the less degree the DNA has to move and the less energy is required to make it vibrate.

Then there are three controlling factors for the DNA to reproduce itself and create a new cell:

- 1) the kinetic energy of the electron in the H-bonds;
- 2) the number of the base pairs per turn in the double helix (DNA);
- 3) the energy and the frequency of charged ions travelling along the nervous system.

That is, the DNA of the embryo cell in the mother womb has 46 base pairs per turn, the kinetic energy of the electrons in the H-bond is weak, and charged ions coming from the mother's body are strong. Result: the DNA produces one cell per second.

After six weeks of pregnancy, the DNA in the cell of the embryo has 34 base pairs per turn; the kinetic energy of the electrons in the H-bonds increases, the charged ions from the mother are unchanged, the DNA produces one cell every minute, and so on. By the time the foetus is in the 10th lunar month, the single DNA (half from the mother, half from the father) has already reproduced itself more than six trillion times.

When the baby is born, the slowing process of reproduction increases. At the age of two, the DNA winds again to have 22 base pairs per turn, 14 at the age of 21, and 10 at the age of 35. From the age of 35 to 55, the 10 base pairs per turn in the DNA do not change. At approximately the age of 55, the base pairs per turn are reduced to six. By this time, the kinetic energy of the electron in the H-bond and the energy of the charged ion become very weak, the DNA stops reproducing itself and the ageing process begins.

To slow down the body ageing process, three factors must be considered:

- 1) Ways of stretching the DNA to increase the base pairs per

turn back to 10, by means of energy in motion up and down along the body, as in the Ring device.

- 2) Ways of increasing the electron kinetic energy in the H-bonds by means of proton pulling force. The proton energy available (as previously explained) toward the centre of the Ring is high enough to attract (in the vacuum) one electron 20 feet away.

- 3) Ways of increasing the energy of the charged ions in the nervous system by means of exercise and proper diet.

### Cancer Cell Formation

At this point, it is necessary to clarify one important factor that is the basic secret of life creation. Without explaining the working principle of this secret, we will never understand the vital importance of the homogeneity and orientation of the magnetic field in the human body.

All the 6.3 trillion DNAs of the human body are absolutely identical; all are tuned to the same resonance frequency; all have exactly the same genetic sequence code. Yet the 6.3 trillion cells in the human body, where each DNA is enclosed, are all different, and each one of these cells fits exactly the proper place and functionality in the human system. How is this possible?

The human DNA, as mentioned before, is approximately one metre (39 inches) long and has six billion steps formed by 12

billion bases. The entire length of the DNA is necessary to maintain and transmit from generation to generation the entire genetic code. Yet only a portion of the DNA (different in every cell) is used to create a specific cell. How is this accomplished?

Suppose we have a thread one metre long. On this thread we insert 46 nylon light beads half an inch long. Let's insert, now, this strange chain in the centre of an electrostatic tube with bipole orientation. After a few seconds, all the nylon beads will be charged with the same electrostatic

energy and they will repel each other, leaving an interspace between them. They will repel each other, but not with the same force. The interspace between the static charge will be shorter; gradually, toward the opposite polarity of the tube, the interspace will be longer. The only part of the thread we see is the part not hidden by the beads.

Let's now call the thread DNA and the 46 beads chromosomes. Since the chromosomes act as a shield, the only portion of the DNA that controls a specific cell is the one of the interspace between the chromosomes, which for every cell has a different length according to different magnetic intensity, polarity and orientation in the human body. Each chromosome encloses 1,250 DNA lengths (genes), and each gene is formed of 100,000 base pairs (microgene). Of the total six billion steps of the ladder (DNA), only 250 million are really controlling the cell life.

The chromosomes appear immediately after the DNA is formed and they disappear when the cell is completed and just before the DNA is ready to repeat itself, to appear again only in the new DNA. If the chromosomes of the new DNA, due to the phenomena previously explained have the wrong interspace sequence, it is quite possible that the DNA will produce, say, in the neck, a cell that belongs to the kidney or vice versa. This can be called *cancer*.

Furthermore, like in a musical instrument, the sound produced

**By this time, the kinetic energy of the electron in the H-bond and the energy of the charged ion become very weak, the DNA stops reproducing itself and the ageing process begins.**

by the DNA in the scanning system has different harmonics according to the chromosome's interspace. The virus responsible for the creation of nucleotides in a different group of cells of different harmonics, adjusts the equilibrium potentials of the component charges in the crystal lattice. This pressure effect in the electrical field distribution governs the final crystal structure of the many compounds of the virus.

If a group of RNA-type virus with a final crystal structure as a result of harmonics of one group of cells is transferred by means of electromagnetic reaction in a different group of cells, under the influence of the new harmonics, it will alter the transition temperature (Curie point). In this transaction, it will lose the protein coating and release the core RNA to control the protein creation in the new cell (Ruben). As a result, a new type of cell will be created that is different from any surrounding cell, and this also will be a cancer cell.

From the above-described phenomena, well known in physics, the Temin theory that the RNA-type virus uses its own RNA core as a template to modify the structure of the genetic code and create the reversal of the DNA is absurd. If the phenomenon exists, it could not be a creation of the present civilisation but has existed from the beginning of time. And there are no records available of claims of apes deriving from humans.

Theories #1 and #4 of the introductory explanation support the principle that some forms of cancer and leukaemia are caused by isolated virus. In this case, a physical principle known as the *pyro-piezoelectric effect* will be the solution to the problem.

If a Rochelle salt crystal is rapidly cooled from 25°C to 0°C, the polarisation increases so fast that the normal conductivity cannot bring about equilibrium, and a transient potential as great as a thousand volts can be produced between the two electrodes contacting the crystal (Ruben).

Since, in the isolated virus crystal, the RNA- or DNA-type core acts as an electrode between the two poles, when the voltage potential overcomes the core's DC resistance the energy discharged across it will be so great as to disintegrate the virus core as a common electric fuse.

The same phenomenon, of course, is applied to the joint virus (one DNA type and one RNA type) existing in the cell nucleus and responsible for the DNA creation. Because of the electrical principle that, in an inductance, two joint EMFs opposite and contrary eliminate each other, no voltage will appear across the joint virus.

In an experiment with dying AKR mice (mice carrying leukaemia), a constant laboratory temperature of 35°C was maintained. The cage containing the mice was placed two times a day for 20 minutes each time in a small refrigerator where temperature was kept at 0°C. After five days of treatments the mice were sacrificed, and pathological studies revealed no evidence of lymphosarcoma. A piezobaric chamber, where a temperature body change of 25°C can be obtained in less than one minute, is under construction to repeat the experiment.

### Reorienting the Magnetic Field with the Dotto Ring

By evenly re-establishing the orientation of the body's magnetic field, the virus groups responsible for the manufacture of the nuclei (necessary to the reproduction of the DNA) are bound to

stay only in the specific group of cells tuned to their own resonance frequency, with no chance of spreading to other parts of the body. With the correction of the environmental resonance frequency of a group of cells, a virus out of position will become inactive in the same fashion as a portion of a variable capacitor not facing the stator.

In theory #3 (Dotto), the Ring re-establishes the proper number of base pairs per turn on the DNA double helix due to the phenomenon known as the *Wunder effect*.

In a vacuum, a suspended secondary coil inserted in a primary coil of a fixed number of turns adjusts itself to the same primary number of turns when voltage is applied, with capability proportional to the current intensity and inversely proportional to the square of the spring reaction strength of the secondary coil. This principle is widely applied in automatic tuning devices for modern colour televisions.

By applying to the human body voltage, EMF and magnetic intensity similar to the value existing in the DNA of normal cells (in the human between the ages of 35 and 55), a voltage of 45 to 70 millivolts maintains a linearity of 10 base pairs per turn in the double helix (Crick and Watson). The DNA of the cancer cell adjusts itself to the proper level of functionality, regardless of cell condition, since absorbed energy will be inversely proportional to the existing cell energy level. In the case of six base pairs per turn

in the double helix (humans over 55), when the DNA stops the reproduction capability the base pairs per turn are triggered back to 10, and so remain as long as the magnetic intensity is reapplied at least once every 14 days. This results in slowing down the ageing process.

Another important factor must be clarified. In widely known mice experiments (Pressman, Barnothy), a combined action of a constant permanent magnetic field and microwaves in the gigacycle range proved to be very efficient in causing

tumour recession in mice. This phenomenon is caused by the disturbance action of the microwaves on the normal orbital spinning of electrons in the DNA H-bonds. But we must not forget that to humans we must give the right to live, not merely to survive.

However, frequencies in the range of 1 to 3 megacycles and modulation frequencies of 80 to 200 kilocycles are known to penetrate deeper into the human body and be capable of breaking the thin skin of the cancer cell without jeopardising the DNA code of normal cells (Pressman).

For this reason, the Ring is pretuned on the Peltier junction to the average frequency of 1.8 megacycles and modulation frequency of 100 kilocycles to obtain a current fluctuation chopping effect similar to a unijunction transistor. The Ring is also a 350-ohm television antenna, where the lower band resonance is tuned to a VHF (Thompson effect junction) and the upper band (Peltier junction) is tuned to a UHF resonance. The upper frequency then maintains, on the correct level, the activity of the normal cell, while the penetrating low frequency neutralises the activity of the cancer cells.

Theory #2, which postulates that cancer cells to some extent may be considered as parasitic cells, is proved correct as far as the Ring is concerned.

The Ring is an inductive coil. In the motion along the body, the

**The DNA of the cancer cell adjusts itself to the proper level of functionality, regardless of cell condition, since absorbed energy will be inversely proportional to the existing cell energy level.**

Ring recharges the cells to the proper, desired level. While the normal cells retain the charge, the cancer cells behave like a faulty battery. At the passage of the Ring, the temporary magnetic charge collapses in the same fashion as transformer lamination. This collapsing effect is detectable by electrodes of an EEG sensitive to electrical brain impulses. By synchronising a recorder to the Ring velocity, the location of the collapsing tumour can be detected with a five-centimetre accuracy.

Many years of investigation have proved the Ring to have no detrimental or side effects. On the contrary, it has proved to be very helpful for people who have suffered from exposure to radiation, cobalt, linear accelerators, etc.

For all the reasons stated above, the Ring should be considered primarily as a tool for physicians in disease prevention and disease control rather than as a cure.

[Signed] Dr Gianni A. Dotto  
Montgomery County, State of Ohio

The above document was signed before me, a notary public, by the said Dr Gianni A. Dotto, this 8th day of February, 1972.

[Photocopied signature unreadable] – Notary Public

#### NOTES FROM JERRY DECKER OF KEELYNET

Years ago I had the pleasure of knowing Arthur Coleman, at one time a key research scientist in Research and Development at Rockwell International. Arthur had a small research lab in Rockwall, Texas, and he was part of our group in Dallas. Arthur was a brilliant engineer and scientist, having developed an iontophoretic device for treating all kinds of disease conditions. In his lifetime, he had been involved with many unusual experiments, some he could only hint about.

One of these was this mysterious Dotto Ring which was said to heal cancer and reverse ageing. After two years of teasing, one day he called me about meeting for brunch, saying he had something for me. We met and he said he had decided to give me a copy of the Dotto papers, explained them and asked me not to post them publicly as they had been handed to him in confidence on a trip to Washington for consulting. I promised.

About five years later, I happened to be at a conference where my friend Dr George Friebott was speaking. After his presentation, we went to lunch and I asked if he'd ever heard of the Dotto Ring. George said he had, and later showed me a copy of the same papers Arthur had given me.

On my return to Dallas, I called Arthur and told him about it. He said that now that it was finally out, I could do with them as I pleased. They were then shared with friends and other networks as well as presented on several occasions over the eight years of the Dallas Roundtable meetings.

NEXUS printed a version of them some years ago [see vol. 2, no. 9, August–September 1992]. I'd mailed out many copies to people who requested them but I never found time to put them online, so here they are. I do see they're being sold elsewhere.

Some correlations and concepts you might find of interest:

- David Hudson claims that monoatomic elements are superconductive and so can store energy. He believes that, when

ingested, they lodge in the tissues and enhance the energy of the "aura", or Kirlian field, which in his opinion is a result of dynamic superconductivity. I like to call it an *attenuated dynamic Meissner field*. It turns out that new, growing tissues are in fact superconducting, so, over time, ingestion of this material is supposed to heal and change your body. I have no direct experience or trustworthy reports about this, but I remain intrigued that a *pure current*, as superconductors possess and which has little if any voltage (produced by resistance), is exactly what Dr Dotto produces with his Ring.

- Nature tends to seek equilibrium; therefore, immersing a body in a high-energy DC magnetic field would cause an energy transfer which would "pull up" the energy in the body due to the "enriched" background. In this case, I think it could well "brighten" the aura or the Meissner field, which is produced by superconductivity.

- Nordic people have been reported to sit in a hot sauna for a period, then run out naked and roll in the snow. Others jump into freezing water after a hot sauna. Note Dotto's mention of the piezoelectric effect where high voltage can be produced inside the body from drastic, rapid, temperature changes. Arthur told me he had bought a metal coffin with the idea of lying in a bath of hot water, then rapidly flushing it with cold water and repeating it as with the mice experiment quoted above. The mice were exposed to 0°C for 20 minutes, but humans might take longer because of

the thickness of the body. The point is to create as rapid a temperature change as possible.

There are reports that the Ring technology was suppressed because the machines would levitate from the floor due to the high magnetic field repelling against the Earth's field. Other reports claim that Sloan-Kettering removed all funding and destroyed the machines because they actually cured cancer! We can't have that: cancer is a very lucrative business!

The last I heard, Dr Dotto had moved back to his family castle in Italy, was now in his 80s and, shall we say, immersed in religion.

Arthur Abraham Coleman passed away at 73 years of age on October 23, 1997 in Rockwall, Texas. He is best remembered for his invention of the chemical milling process for bonding metals together (which is used on most airplane wings) as well as his remarkable electrotherapy device (used by many doctors).

The Dotto Ring US patent number is 3,839,771 (Method for Constructing a Thermionic Couple). Dotto's Electrostatic Wand patent number is 3,785,383. If you have additional information or updates regarding the Dotto Ring or related technology that you would be willing to share online, please contact Jerry Decker. Thanks!

If you found this file useful or interesting, please consider a donation or a purchase to help keep KeelyNet online and providing free information. Even a dollar will help. Others sell it; we prefer to share it!

#### Editor's Note:

This file was posted on December 17, 2001, and is reproduced with permission from Jerry Decker of KeelyNet. Contact: KeelyNet, PO Box 111786, Carrollton, Texas 75011-1786, USA, email [jdecker@keelynet.com](mailto:jdecker@keelynet.com), website <http://www.keelynet.com>.

# THE PICK OF THE 2002 CROP CIRCLE SEASON

*After a slow start in England, the 2002 circle season sprang the phenomenon's usual surprises, including a mysterious image of an ET holding out an inscribed disc.*

**by Andy Thomas © 2002**

Swirled News  
Southern Circular Research  
13 Downsview Cottages  
Cooksbridge, East Sussex, BN8 4TA  
United Kingdom

Websites:  
<http://www.swirlednews.com>  
<http://www.vitalsignspublishing.co.uk>

In the traditional British heartlands of the crop circle phenomenon following a year of foot and mouth disease, hoax paranoia and then two stunning circular events at Milk Hill and Chilbolton which cleared the air somewhat, the 2002 season promised a much cleaner slate.

Yet it looked for a while like nothing was going to happen at all. Events began very slowly—the slowest for several years—with a modest, ringed circle in a rape crop at Soberton, Hampshire, on 12 April. It then took a long while to get going before the masterpieces the UK was used to seeing returned, with only three minor formations reported in May. Events began properly at Avebury Trusloe, Wiltshire, on 2 June, with an attractive Celtic-looking design resembling a sixfold knotted string within a ring of beads.

Though progression was slow, there was a scattering of other noted formations throughout June. One was a beautiful double spiral at West Overton, Wiltshire, on 23 June, whilst the county of West Sussex also delivered some fine patterns. One of two formations at Sompting was a convex triangle design found (by myself and Allan Brown) to contain a thick but fine white dust deposited inside. When Rodney Ashby (as recommended by Nancy Talbott of BLT Research) analysed the dust, he found it to be a particularly pure form of silica, very unlikely to be found in a field. No explanation could be found for its presence, but Nancy later revealed that such dust has recently been found in other formations around the world.

Despite these offerings, it wasn't really until July that the UK scene came properly to life, finally delivering the numbers and array of ingenuity expected for the time of year. But then, what are the expectations with the crop circles, which always seem to confound predictions and complacency?

It has now become traditional to await the arrival of the hugest formation of the year as some kind of "grand finale", as with the astonishing 800-foot Milk Hill spiral of the preceding year, but in 2002 the largest-diameter formation (at least at the time of writing, in late August) arrived on 4 July near Stonehenge, Wiltshire. It was a wonderful 741-foot design, resembling six ribbons three-dimensionally fluttering in the wind. What impressed as much as its shape (actually, made from very straightforward curves) was its positioning within the field, poised perfectly between three round barrows and the perimeter of the field, with little margin for error. Michael Glickman likened the task to "lowering an oil tanker into Trafalgar Square".

This was the first formation of the year to catch the attention of the British media, and it found its way into newspapers and television reports to a suitably impressed public. But the UK is already well conditioned to the presence of crop circles. In the USA, many were discovering the phenomenon for the very first time—perhaps incredibly to British eyes—thanks to one particular film...

August 2002 saw the US release of the movie *Signs*, starring Mel Gibson—a spooky UFO-invasion thriller in which tall green aliens create formations in maize crops as landing beacons for their craft. Putting aside the unoriginality of the plot and the portrayal of the crop circles as something so disappointingly mundane, the fact is that the movie raised the profile of the real phenomenon to a huge degree, bringing it to the attention of many Americans whom it had somehow previously bypassed. Magazines and newspapers swelled with articles and the airwaves buzzed with radio and television documentaries, news features and phone-ins on crop circles as if they had never existed before.

It's interesting to note that most US "croppies" were deeply unimpressed with the film, many considering it a fear-mongering distortion of the true phenomenon, but those new to

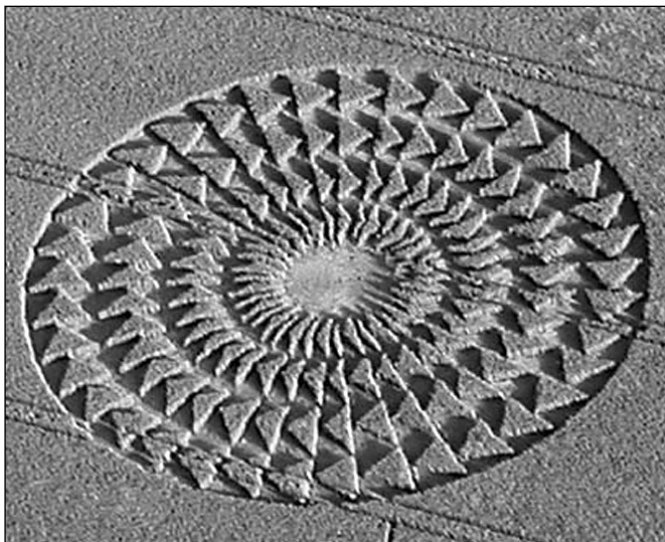

Windmill Hill, near Avebury, Wiltshire. Reported 2nd August.  
Image M. J. Fussell © 2002

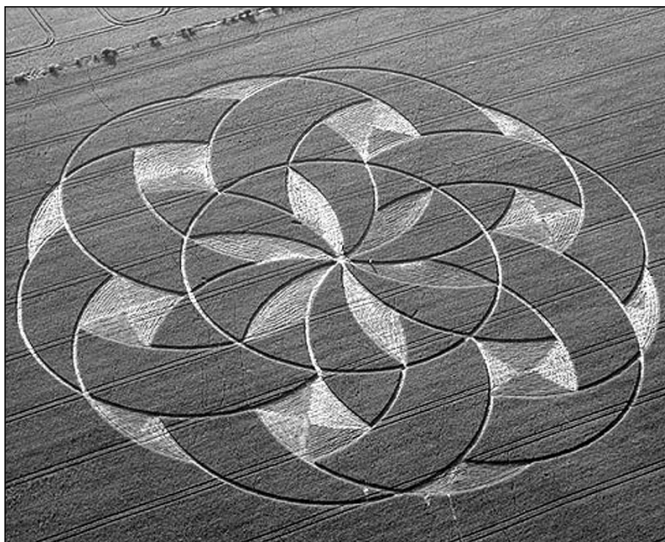

Nursted, near Devizes, Wiltshire. Reported 11th August.  
Image M. J. Fussell © 2002

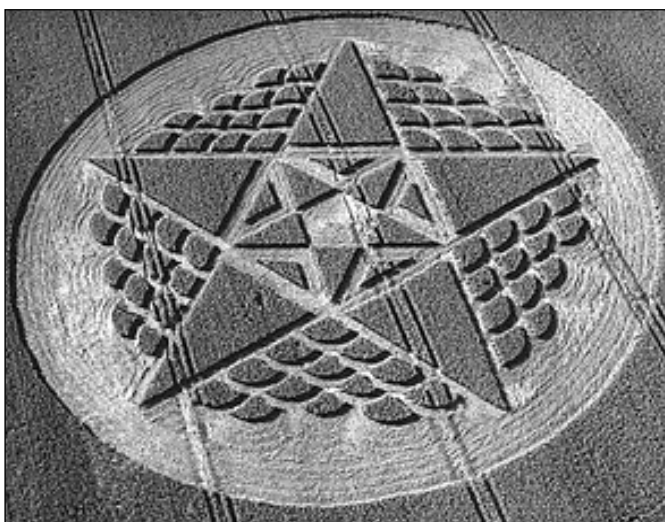

Beckhampton, near Avebury, Wiltshire. Reported 26th August.  
Image M. J. Fussell © 2002

the concept of the circles in any light suddenly became exposed to the existence of the real thing. Cereological interest from the States became intense, and circle websites saw the effect as hit-rates rapidly increased.

A positive documentary movie, *Crop Circles: Quest For Truth*, by award-winning US filmmaker William Gazecki, was planned for release in late [northern] summer, too, to set straight any Hollywood misconceptions about the real phenomenon. A 45-minute excerpt was premiered at this year's Glastonbury Symposium crop circle conference (in its new, bigger venue) and was well received.

With all this newfound interest, there was a suspicious rise in the number of US formations, though those who believe the phenomenon to be psychically interactive defended this development as inevitable and positive.

The debunkers were also on hand to capitalise on the newfound interest. As the movie-inspired circle coverage increased, their claims that all crop circles are man-made became more prominent, as spokespersons for the rather sinister Inquisition-like elite organisation CSICOP (Committee for the Scientific Investigation of Claims of the Paranormal) found louder voices, and the usual human circle-making teams found new platforms from which to dispense their scepticism. One thing the film does not do is debunk the circles—which would have been a dramatic let-down. So the sceptics have had to find even louder voices this year, with probably a major debunking still on its way at the time of writing, courtesy of a conglomeration of known UK human circle-makers promising something spectacular, probably timed to coincide with the UK release of *Signs* in September.

Elsewhere in the world, aside from Hollywood's intervention, crop circles increased their profile in a number of places—notably Germany, which, for a time until July, had more crop circles than the UK, with a series of intriguing if less ambitious designs, some of which utilised more unusual crops than the routine grain-types. A formation on the Isle of Ruegen at Mecklenburg-Vorpommern, for instance, appeared in a field of white clover and purple phacelia flowers, creating a rather beautiful effect. Canada also continued its increased sightings, and The Netherlands was again a contender in the numbers stakes.

But by the middle of August, the UK had caught up from its late start and was producing some extraordinary patterns, though some feared a deliberate increase in man-made formations as a result of

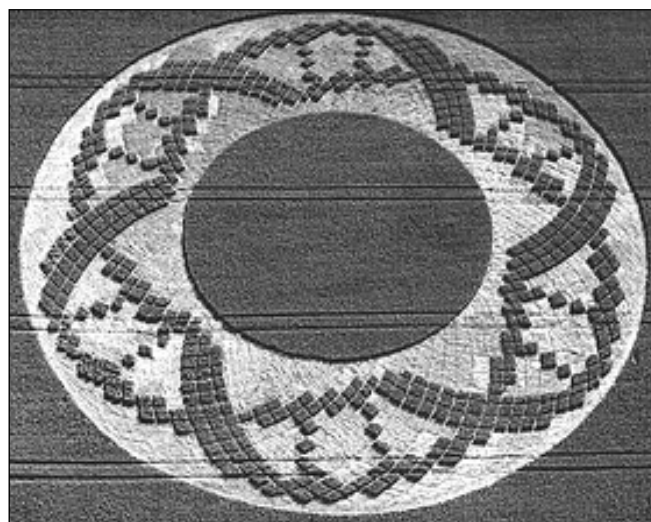

Crooked Soley, nr Hungerford, Berkshire. Reported 28th August  
Image M. J. Fussell © 2002

the extra publicity from *Signs*, which was less acute in the UK but still noticeable.

One or two formations this year surprised by being overtly pictorial in their nature—such as the one which appeared at Alton Barnes on 15 July and appeared to resemble an apple tree, or a mushroom if turned upside down. Later, on 14 August in the same field, another dramatic emblem depicted two stylised dolphins leaping around a triple-ringed circle. A few saw this as a beautiful, but cautioning, representation of the negative effects of sonar on these aquatic creatures. Some were not happy with such unambiguous designs, but the mother of pictorial formations was to upset things further...

On 15 August, a year and a day on from the amazing Chilbolton "face" and "message" formations which confounded the circle community in 2001, another representation of a face—this time almost certainly a classic-looking "ET", complete with shoulders and chest—arrived at Crabwood, near Winchester, Hampshire, just a few miles from Chilbolton. Instead of an accompanying radio telescope, this time a microwave transmitter complex stood nearby; and instead of the separate play on the message we beamed out into space in 1974, as embodied in last year's "code", this time a large spiral disc of small rectangular dots and dashes was superimposed over the corner of the ET illustration, clearly containing digital information.

The first attempts at decoding the disc as ASCII text code came through quickly. The message appears to read as follows, written exactly as it translates:

"Beware the bearers of FALSE gifts & their BROKEN PROMISES. Much PAIN but still time. EELIJ?E [this word is damaged and unclear, but some say it may be meant to read "BELIEVE"']. THERE IS GOOD OUT THERE. We OPpose DECEPTION. Conduit CLOSING." (A bell sound is then signified.)

Perhaps with the thought of "false gifts" in mind, opinion was divided over the nature of the symbolism, being just too overt for some people. Some found the ET creepy and threatening, while others thought it had a playful, mischievous nature. Some felt this was another agency at work altogether from the usual circlemaking forces, and inevitably many others were highly dubious as to its authenticity, especially with all the attendant *Signs* fuss. Yet its construction was ingenious. Instead of half-tone dots, as found at Chilbolton in 2001, this face and body were formed from thin

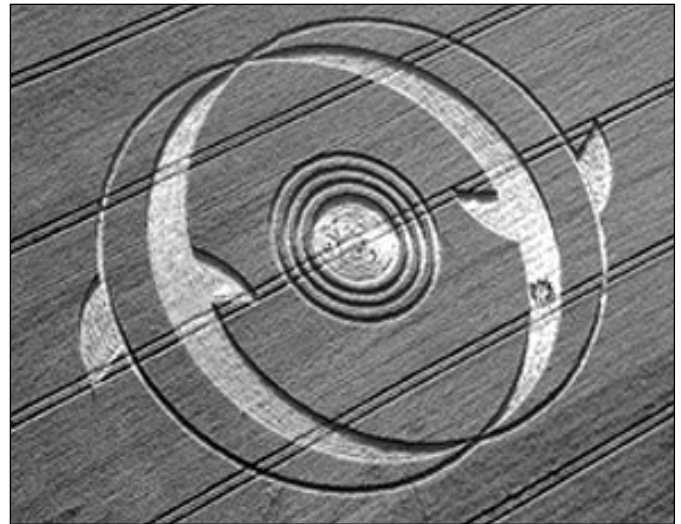

East Field, near Alton Barnes, Wiltshire. Reported 14th August. Image M. J. Fussell © 2002



Pewsey White Horse, near Pewsey, Wiltshire. Reported 17th July. Image Steve Alexander © 2002

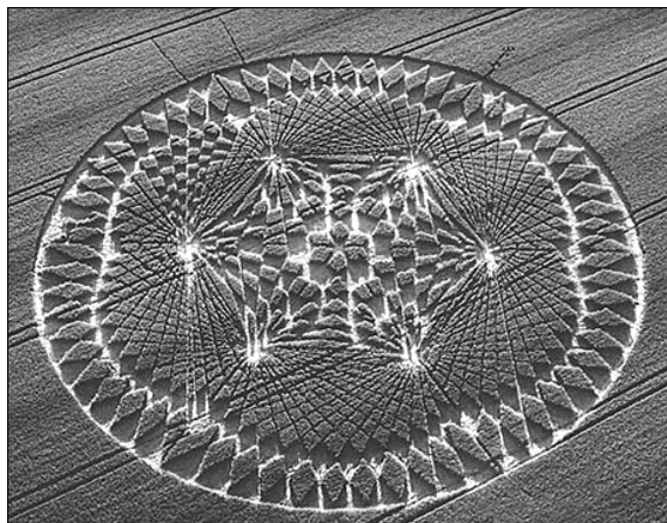

Windmill Hill, near Avebury, Wiltshire. Reported 18th July. Image Steve Alexander © 2002

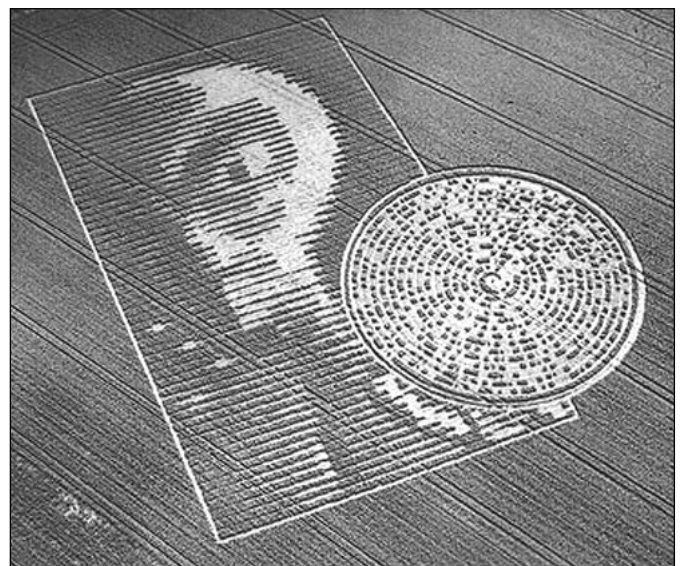

Crabwood Farm House, near Winchester, Hampshire. Reported 15th August. Image Steve Alexander © 2002  
The circular ASCII code has been translated to read: "Beware the bearers of FALSE gifts & their BROKEN PROMISES. Much PAIN but still time. BELIEVE. THERE IS GOOD OUT THERE. We OPpose DECEPTION. Conduit CLOSING."



South Field, near Alton Priors, Wiltshire. Reported 22nd July.  
Image Steve Alexander © 2002

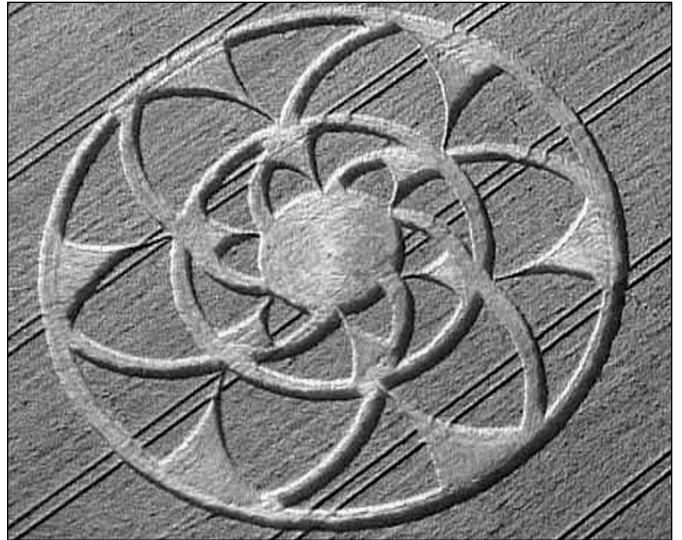

Barbury Castle, near Wroughton, Wiltshire. Reported 24th July.  
Image Stuart Dike © 2002



Telegraph Hill, Lilley, near Luton, Hertfordshire. Reported 1st June.  
Image Russell Stannard © 2002



Avebury Trusloe, nr Beckhampton, Wiltshire. Reported 2nd June.  
Image Steve Alexander © 2002

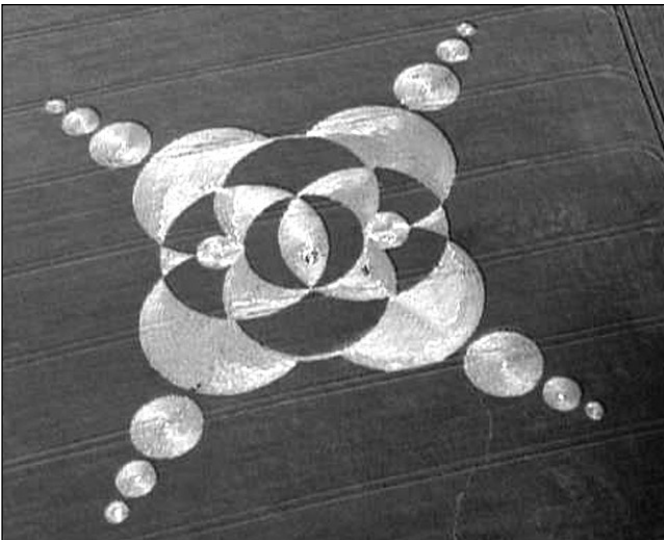

Silbury Hill, near Avebury, Wiltshire. Reported 4th June.  
Image Stuart Dike © 2002

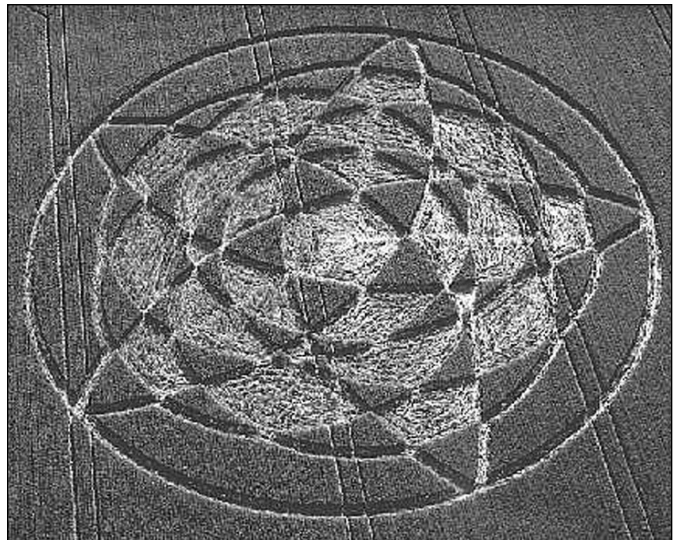

Avebury Stone Circle, near Avebury, Wiltshire. Reported 21st June.  
Image Steve Alexander © 2002

scanning lines, widening at different intervals to create the pattern. Ground observation was meaningless without an aerial visual reference. The debates will doubtless continue for a long time.

As I write, there is a hope for perhaps one more "biggie" to come, aside from any glitzy but hollow distractions human circlemakers may create for PR purposes. However, the astonishing formation which appeared on 28 August at Crooked Soley, near Hungerford in Wiltshire, may well have been the grand finale: a wide ring with a DNA-type spiral of blocks running through it in a 3D mosaic fashion. Its geometric construction is remarkable and its implications are intriguing, if unsettling.

Now the fields are rapidly falling to the harvesters, closing a curious season marked more by new attention to the phenomenon than any overtly new behaviour from it, with the obvious exceptions.

Whether by next year, especially when the debunkers have finished their work, the crop circles will be seen as "last year's" faded fad remains to be seen, but many will celebrate the year in which attention—even if the Hollywood trigger for it was essentially superficial—was drawn in a big way once again to the ever-continuing mystery in the fields.

**About the Author:**

Andy Thomas is author of *Vital Signs: A Complete Guide to the Crop Circle Mystery and Why it is NOT a Hoax* (see review this issue), and editor of the Swirled News website, [www.swirlednews.com](http://www.swirlednews.com).

**Special thanks to the folks at [www.CropCircleConnector.com](http://www.CropCircleConnector.com) and to Steve Alexander at [www.temporarytemples.co.uk/](http://www.temporarytemples.co.uk/)**

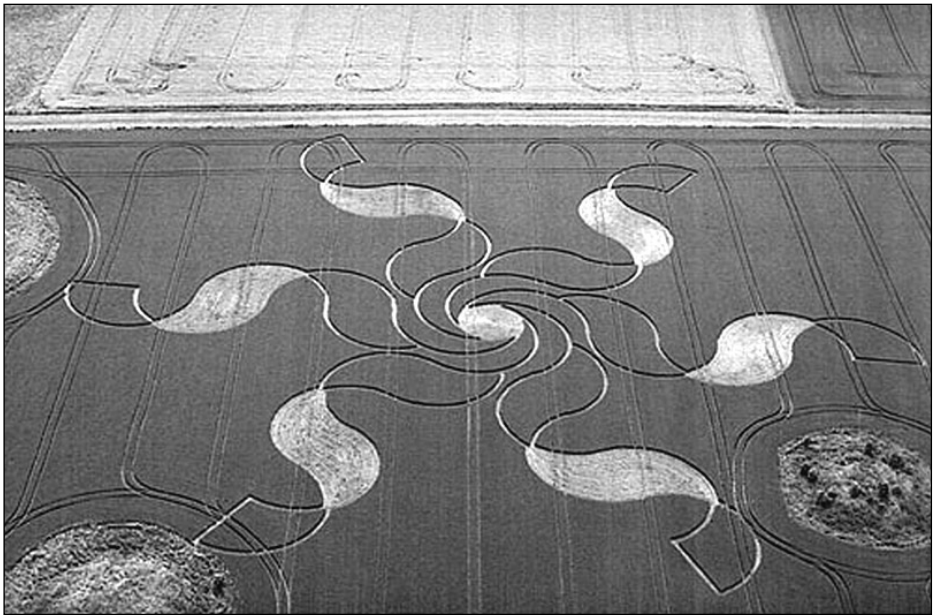

Normanton Down Long Barrows, near Stonehenge, Wiltshire. Reported 4th July. Image Steve Alexander © 2002

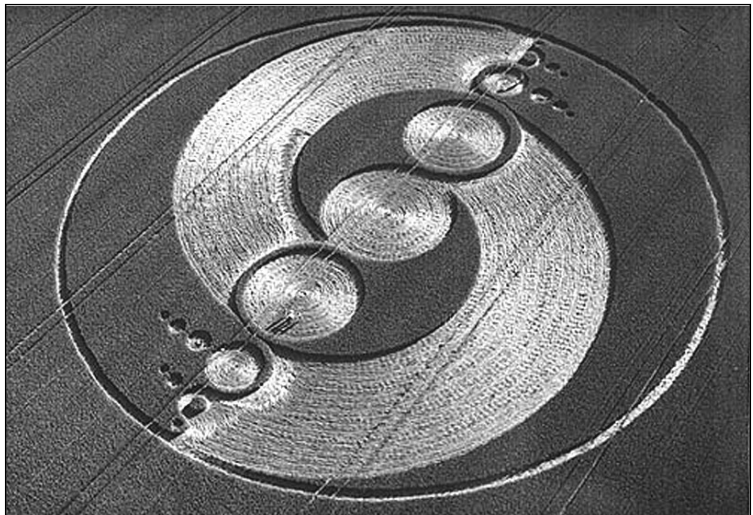

Avebury Stone Circle, near Avebury, Wiltshire. Reported 28th July. Image Steve Alexander © 2002

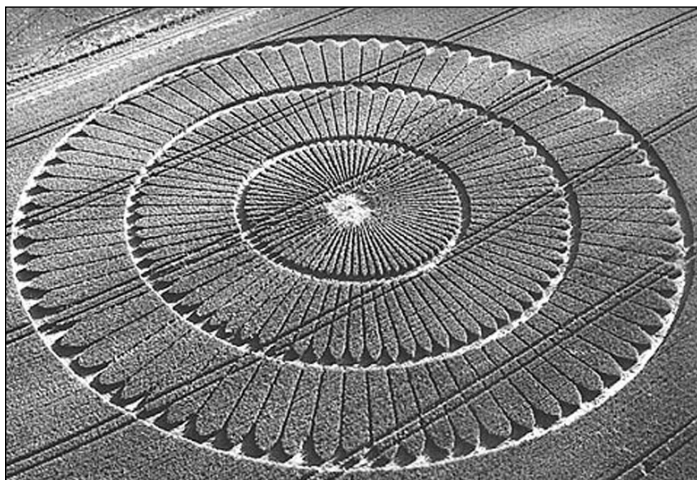

The Gallops, nr Beckhampton, Wiltshire. Reported 28th July. Image Steve Alexander © 2002



North Farm, nr West Overton, Wiltshire. Reported 23rd June. Image Steve Alexander © 2002





## ALIEN ARTIFACTS IN AMERICAN HANDS IN THE LATE 1930s?

by George A. Filer © August 2002

**W**illiam E. Jones of the Center for UFO Studies (CUFOS) writes: "I thought your readers should be aware of the Cordell Hull story that alien artifacts were in our hands in 1939."

In early December 1999, CUFOS received a letter from the daughter of the Reverend Turner Hamilton Holt:

"Today I want to share some knowledge that has been, by request, kept secret in our family since sometime in World War II. This concerns something my father was shown by his cousin Cordell Hull, the Secretary of State under [US President] Franklin Roosevelt. My father, who was young, brilliant and sound of mind, told us this story because he didn't want the information to be lost.

"One day when my father was in DC, Cordell swore him to secrecy and took him to a sub-basement in the US Capitol building and showed him an amazing sight: (1) four large glass jars holding four creatures unknown to my father or Cordell; (2) a wrecked round craft of some kind nearby.

"My father wanted my sister and I to make this information known long after he and Cordell were dead, because he felt it was a very important bit of information.

We have researched your group and feel it is the most reliable group in the country. We hope that you will research and search this information. The jars with creatures in formaldehyde and the wrecked craft are somewhere!

"Cordell said they were afraid they would start a panic if the public found out about it."

"Sincerely,  
"Lucile Andrew, Ashland, Ohio"

**C**ordell Hull was one of the greatest statesmen of the 20th century, with absolutely no apparent reason to tell this story unless it were true, especially at a time when stories of flying saucers and their alien drivers had not yet become part of our culture.

Hull was an elected US Senator (1931–1937), was Chairman of the Democratic National Committee, and became the Secretary of State under President Franklin D. Roosevelt in March 1933, the longest-serving Secretary in US history when he resigned in 1944 because of ill health. He was also offered the Vice Presidency and, in 1945, he won the 1945 Nobel Peace Prize.

Reverend Holt and Cordell Hull were both born in Pickett County and were cousins and friends. Holt received his doctorate in theology from Ashland

Theological Seminary, and was a minister at the Shenandoah Christian Church in Greenwich, Ohio. He was a community leader, and he wrote a book entitled *Life's Convictions*. He married Vina May Clark and they had three daughters.

Two of the daughters claim their father had told them about the "creatures". Lucile's original letter essentially tells the story as her father told it to her when she was a teenager.

Unfortunately, Lucile said that she was too young really to pay much attention to what her father told her, but Allene—the mother of Eloise, the co-author of this story—was told the same story as her sister. Both sisters assured us that they remember the stories independently.

Reverend Holt described the entities in the glass jars as "creatures", a term common for his day. He never referred to them as "aliens" or "extraterrestrials", and he never said where they came from.

Lucile stated that his experience happened in the "late 1930s", probably 1939. The material that was nearby the less-than-four-foot-tall creatures was described as "silver metallic". She also remembers he referred to the material as being a "vehicle" that appeared to have been taken apart and was "in pieces". He said the colour of this material wasn't a colour that he had seen before, but for the lack of a better word he

used "silver". Reverend Holt was not the sort of person to make up such a wild story, and the sisters feel that by telling the story they are following their father's wishes.

Barbara A. Wolamin, the curator at the US Capitol building, chuckled a bit after being told the story. She said she had never heard about these creatures being stored at the Capitol, but she did confirm that back then there was a sub-basement that was divided into storage rooms. She said the building had been significantly changed over the years. So, in a small way, part of Reverend Holt's story checked out.

After Cordell Hull left government service, he wrote his memoirs in a two-volume book set. No reference to this story appears in these pages, among his papers in the Library of Congress. We contacted numerous experts and libraries and found no confirmation for the story.

If four alien bodies and other-world technology were retrieved in 1939, what would that do to our interpretation of the US government's involvement in UFO research? One would assume prior knowledge would have made the government ready for an event like Roswell and that the Roswell retrieval was more efficient because of that. This is a story that truly deserves further investigation.

Thanks to William E. Jones, MUFON State Director for Ohio, Dr Irena Scott and CUFOS *International UFO Reporter*.

(Source: By George A. Filer, Director, Mutual UFO Network Eastern Region, "Filer's Files", no. 32, August 7, 2002, website <http://www.filersfiles-ufo.com>)

## LEAKED PAPERS SHED LIGHT ON OFFICIAL SECRECY OVER UFOs

The Majestic Documents investigation team has recently posted a set of four leaked UFO-related documents to its website, <http://www.majesticdocuments.com>. They arrived anonymously in UFO researcher Tim Cooper's Big Bear, California, mailbox in July 2001.

### National UFO Intelligence Program

The first document is a two-page Secret memorandum from President Dwight D. Eisenhower to the Director of Central Intelligence, dated November 4, 1953.

The document deals with Eisenhower's comments on an "MJTWELVE Operations Plan of June 16, 1953 on the subject of instructions for the expenditures of the National UFO Intelligence Program, and, more specifically, the Special Operations Instructions to be issued to Unified and Specific Major Commands and Commanders". In the memorandum, Eisenhower:

(a) expresses concern about inflaming the UFO situation with the Soviets;

(b) reiterates that both the CIA and the NSA have leading roles to play in the UFO program; and

(c) confirms that both Dr Robert Oppenheimer and Professor Albert Einstein (described as the Director of Project JEHOVAH) were involved in research relating to UFO physics.

Both original and replica documents can be downloaded at:

[http://209.132.68.98/documents/pdf/eisenhower-dci\\_4nov53.pdf](http://209.132.68.98/documents/pdf/eisenhower-dci_4nov53.pdf).

## UFO Violations of US Airspace

The second is a seven-page document attributed to the Office of Scientific Intelligence in 1976. This photocopied onionskin document is titled "UFO Sovereignty Over Air Space: A Defense Intelligence Problem". The document is signed by "LCR"—the initials of an astronomer attached to the CIA's Office of Scientific Intelligence in the 1970s.

LCR talks about the way in which UFOs have violated US airspace on numerous occasions; the way in which Top Secret UFO data have been withheld from elected leaders by the CIA; the recovery of a crashed UFO in New Mexico in 1947 by the Armed Forces Special Weapons Project; the fear of a nuclear confrontation with the Soviets being prompted by UFO radar tracks; President John F. Kennedy's involvement in the UFO controversy; UFOs and the Cuban missile crisis of 1962; and LCR's initiative to begin reintroducing presidential briefings on the UFO subject.

The discussion of organisational slow-downs, denied information and management dilemmas are typical of bureaucracies, irrespective of topic. Such references in the discussion are consistent with a pragmatic working document, not for sensationalism or public melodrama.

The document in both its original and replicated form can be downloaded at: <http://www.majesticdocuments.com/documents/1970-present.html>.

## UFOs, the CIA and National Security

The third paper is an Executive Briefing document for the Director of Central Intelligence, titled "Unidentified Flying Object: Implication for Nation Security and Human Survival".

It provides a three-page introduction to a paper of undetermined length, written by LCR in December 1976. LCR reveals that between 1946 and 1955, he compiled information on UFOs and the US intelligence community that was included in his book, *Central Intelligence, UFOs and National Security*, published in 1956 by the CIA. It reveals the surprising fact that many secret documents concerning UFO encounters at Los Alamos and the White Sands Missile Range in the period 1944–1949 were destroyed, and also reveals how this caused problems in trying to evaluate the true picture from an historical perspective.

The paper also touches upon the CIA's role in espionage and UFO investigations,



MEN IN BLACK



MEN IN DARK

as well as LCR's examination of the CIA's historical UFO studies.

The original and replica documents can be downloaded at:

<http://209.132.68.98/documents/pdf/ufo-implicationforinformationsecurity.pdf>.

## Dr Edward Teller Advocates Less Official Secrecy on UFOs

The fourth paper in the collection, titled "UFO Technology and the Imbalance of Power", is attributed to scientist Dr Edward Teller and is a five-page photocopy of the onionskin-paper original (~1980s). It goes into great detail about the nature of official secrecy and the benefits and hazards of secrecy both in the Cold War and beyond. Dr Teller proposes that official secrecy surrounding UFOs should be lessened for three prime reasons:

(a) to stimulate research in the field of military applications of UFO technology;

(b) to promote cooperation between the US and its allies around the world on the UFO issue; and

(c) to inform the US public of "the true state of UFO reality".

Dr Teller also proposes that the majority of classified UFO documents should be declassified. In addition, he discusses the use of UFO technology integrated into the US military's remotely piloted vehicle (RPV) program, and maintaining an adequate defence against "UFO nuclear weapons".

The original and replica documents can be downloaded at:

<http://209.132.68.98/documents/pdf/ufotechnology-teller.pdf>.

(Source: From *Majestic Documents investigators* Ryan S. Wood and Dr Robert M. Wood, August 29, 2002, email [rswood@majesticdocuments.com](mailto:rswood@majesticdocuments.com), website <http://www.majesticdocuments.com>)

## A JOINT MILITARY EXERCISE WITH ALIENS IN ARKANSAS?

An American officer, who wished to remain anonymous, has affirmed that aliens took part in a military exercise that took place in Arkansas, USA, several years ago.

"There are some things that I cannot talk about. Yet, I think I can say something."

Airborne troops conducted their exercise from April 15 to May 5, 1992. The event took place on the territory of the Fort Chaffee army base. The exercise was

performed under the code name, Operation *Curtain*. Special units of airborne troops from Venezuela, Ecuador, the USA and Puerto Rico took part in the exercise. The troops were sent to swamps in a remote part of the base. They were ordered not to allow the dummy bridge that was built for the exercise to be exploded.

"No unit managed to prevent the explosion of the bridge. Neither the Venezuelans, nor Americans, nor the soldiers from Ecuador managed to detect the 'enemy'. No one could understand how the saboteur made its way without even bumping into any of the best units. Nevertheless, it happened," said the officer.

Commandos from Puerto Rico encircled the swamp and started waiting for the "enemy". "A strange noise could be heard in the distance at about 0030 hours. Soldiers thought that the 'enemy' had landed on the other side of the swamp. Everybody was ready to meet them. The only aspect that we did not know was the time that it would take for the 'enemy' to cross the swamp. Before the exercise started, the commandos were given an order not to use night vision devices. However, there was an American sergeant among the Puerto Ricans who had such a device.

"The soldiers soon heard strange sounds coming from the other side of the swamp. The sounds were getting more and more distinct. Everybody was staring in the direction of the sound, but no one saw anything at all.

"Suddenly, everyone smelled the strong smell of the swamp. One of the Puerto

Rican officers ran out of patience and asked the American sergeant to give him the night vision device. The officer looked around the territory and he saw three small creatures. They were visible with the naked eye. The officer gave the night vision device to another officer and so on. Everybody saw the weird 'enemy'.

"The soldiers eventually contacted their command. The command kept silence for a long while, and then it was ordered that they carefully watch the creatures without bringing harm to them.

"They were like little people, about one metre high. They looked absolutely white in the night vision devices. There was another such creature sitting on a stump, as if it were watching the crawling ones. At first I thought that they were wearing some kind of helmets. But then I realised that they were not helmets, but their long, egg-like heads. I could even see their big black eyes with no eyeballs. It also seemed to me that they had two little holes instead of a nose. I did not see a mouth. They had four fingers on their hands."

The officer also said that a helicopter arrived soon after and took the "little people" away. The command strictly ordered everyone to maintain silence about the event. The American officer was struck with what he saw. He did not say anything about it for two years. Who were those creatures? What were they doing among military men? How far did it all go?

(Source: Pravda, September 4, 2002, website <http://english.pravda.ru/main/2002/09/04/35979.html>)



# THE TWILIGHT ZONE

## MASSIVE BARRIER ENCIRCLES GIZA PYRAMIDS COMPLEX

Since the beginning of 2002, Dr J. J. Hurtak and a European team of investigators and explorers have been recording the construction of a massive system of walls being placed around the historic pyramidal sites and the larger unexcavated area of Giza, Egypt—in total, an area covering approximately eight square kilometres.

Why build these massive walls at this time? Certainly Giza is one of the finest archaeological zones of the world. Are there new treasures of ancient Egypt yet to be uncovered, that require sophisticated technology and surveillance platforms to protect the ongoing research along the Giza plateau? Has, perhaps, an area been discovered that shows tracings of rare earths and unique minerals? Or is it simply, as some officials are claiming, a move to protect the plateau from terrorists and control the masses of tourists visiting the area?

The standard argument for the creation of such a wall is "crowd control", but the details of this new construction suggest an initiative that is both multipurpose and grand scale. The wall near Nazlet al-Samman will be, at a minimum, seven metres (22 feet) high. Are such measures solely for crowd control?

The walls have been built in stages. Images taken in February 2002 reveal the walls extending far out into the desert—where, for the most part, they have not been noticeable to the average visitor.

Note the foundation and the massive rebar supports [see photos on website]: the

walls have been carefully constructed on a deep, wide foundation (at least two metres below ground), with iron rods poised to support the concrete interfaces and with room for a special attachable cover. All in all, this suggests a gargantuan wall.

This barrier would enclose all major archaeological activity but would do nothing to protect the archaeological site from the strong winds that blow across the plateau. So vast is this structure that some local village homes have been removed, suggesting that what is envisioned on the plateau is more than just a restricting device for visitors to the popular site. What we see is a larger, carefully thought-out design, encompassing neighbouring findings and, perhaps, protecting underground graves, tunnels and passages.

Thus, not only are the aboveground structures contained in this "new zone", but also the vast underground structures yet to be uncovered. The extent of the walls clearly shows the detailed consideration of civil engineers and hydrological experts. (I think of the likes of the ingenious Italian architect Paolo Soleri, who designed all the ingredients for an underground city to match his aboveground city in the desert of Arizona.)

The psychological reality of guards stationed as sentries at intervals along the entire wall carries the intrigue of a major feature film set, designed for the few experts who are to find an underground sphinx or obelisk or a connection between Osiris and the constellation of Orion, rather than being an open door for thousands of well-behaved international students of

history and archaeology who have never needed to be extensively controlled.

Indeed, are the chambers of the deep being closed in the 21st century to students of world cultural history, who follow in the footsteps of explorers like Charles Piazzi Smyth and R. A. Schwaller de Lubicz who entertained a higher meaning to Egyptian architecture? Are these sites now being closed to technologically gifted explorers at a time when new protohistoric findings could serve to unite the various camps of thinkers and philosophers in the Near East on the basis of a grand history for all people? We hope that newly discovered realities within the walls will not be limited to the few, and that there will be no concealment of important historical information that could bring a higher knowledge and unity to all humankind.

(Source: By Dr J. J. Hurtak, *Academy for Future Science*, 2002, [http://keysofenoch.org/html/giza\\_update.html](http://keysofenoch.org/html/giza_update.html))

## RAINFOREST RESEARCHERS STRIKE PAY-DIRT

It shouldn't be there, but it is. Deep in the central Amazonian rainforest lies a rich, black soil, known locally as *terra preta do Indio* (Indian dark earth), that farmers have worked for years with minimal fertilisation. Until now, archaeologists believed *terra preta*, which may cover 10 per cent of Amazonia, was the product of intense habitation by Amerindian populations who flourished in the area for two millennia. But recently unearthed evidence reveals that societies lived and farmed in the area up to 11,000 years ago!

As reported in the August 9 issue of the journal *Science*, such longlasting fertility is an anomaly in the tropics, where punishing conditions make the land highly acidic, low in organic matter and nearly incapable of sustaining life.

What researchers find most remarkable is that instead of destroying the soil, the original inhabitants *improved* it—something ecologists don't know how to do today. Although the project is in its early stages, scientists hope to learn the principles behind *terra preta*. The ability to reproduce the superfertile soil could have broad impact, making it possible to sustain intensive agriculture in the Amazon and other hot regions.

(Source: *University of Vermont*, August 29, 2002, [http://www.eurekalert.org/pub\\_releases/2002-08/uov-rrh082902.php](http://www.eurekalert.org/pub_releases/2002-08/uov-rrh082902.php))

## UFO checklist

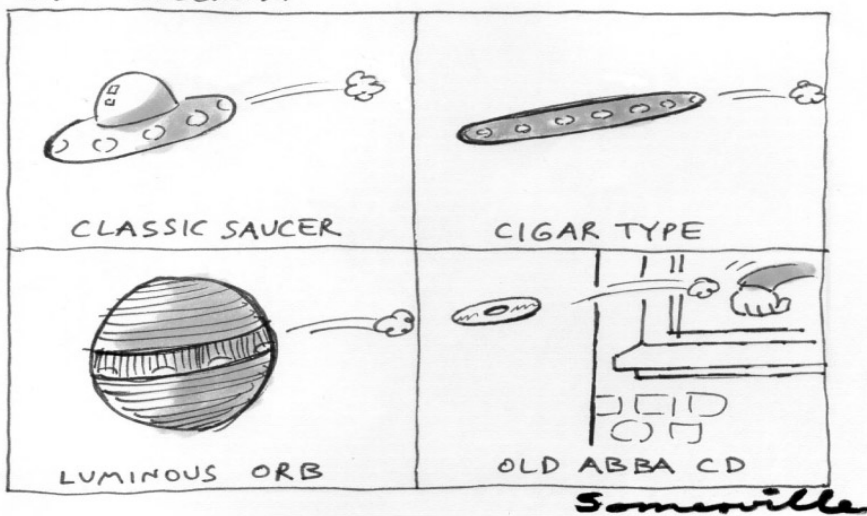

# REVIEWS



## BOOKS

Reviewed by Ruth Parnell

### VITAL SIGNS

by Andy Thomas

S B Publications, UK, 1998, revised and updated 2002; Frog Ltd, USA, 2002  
ISBN 1-85770-256-5 (UK) (192pp tpb);  
1-58394-069-03 (USA) (192pp tpb)  
Price: £14.95 + £1.60 p&h in UK, £5.75  
to USA, £6.00 o/s p&h elsewhere;  
Euro 26,90; US\$20.00

Availability: **UK**—Vital Signs, 13  
Downsview Cottages, Cooksbridge, East  
Sussex BN8 4TA, website <http://www.vitalsignspublishing.co.uk>; **UK/Europe**—  
NEXUS offices; **USA**—Frog Ltd,  
<http://www.northatlanticbooks.com>

The crop circle mystery deepens every year, and 2002 produced a few more surprises. For those prepared to think outside the square and dismiss mainstream media claims that the glyphs are designed and made by hoaxers or "plankers", then Andy Thomas's revised edition of his 1998 book *Vital Signs* is a must-read, even if you have the original version (see review, 5/06). (Thomas contributed his perspective on the 2002 season for our coverage this issue.)

This new edition contains another 48 pages and includes a selection of the best crop circle images (in colour) from the intervening four years, revisions on the earlier text and updates on the chronology of the English glyphs. These formations, however fleeting their existence in the fields, however scientifically baffling and strange their effects on those who visit them, are far too beautiful and mysterious not to be documented, so

Thomas has diligently carried on this task with the aid of fellow researchers and a group of intrepid aerial photographers (see website <http://www.swirlednews.com>). There are over 260 colour and b&w images here, and the foreword is by Mike Leigh, film director and former "closet croppie". There's also an extensive bibliography.

If you're a newcomer to the field and may have seen the Hollywood film *Signs*, then this book could be vital to your education.

### SECRETS IN THE FIELDS: The Science and Mysticism of Crop Circles by Freddy Silva

Hampton Roads Publishing, USA, 2002  
ISBN 1-57174-322-7 (332pp tpb)  
Price: A\$46.00; NZ\$66.95; £16.95; Euro  
25.90; US\$19.95 (US\$14.00 on the web)  
Availability: **Australia**—Gemcraft, tel (03)  
9761 5535; **NZ/UK/Europe**—NEXUS  
offices; **USA**—Hampton Roads, tel (804)  
296 2772, website <http://www.hrpub.com>

Appearing in the fields in greater numbers and sophistication since the late 1980s—mostly in England but also in two dozen other countries—the crop formations inspire so much awe that they could well be the new temples of our times. Most who have stood within a crop circle would agree.

In *Secrets in the Fields*, researcher Freddy Silva, who's based in Wessex, England, considers why and how the crop circles might have the effects they do on their beholders. Silva has made a fitting selection of b&w and colour photos (many are his own) plus diagrams which he uses with rivetting effect. He explores the historical data, scientific evidence, geometries and symbolisms, and talks to fellow researchers and individuals whose lives have been touched by them.

While Silva, like other researchers, can only speculate on the identity of the Circlemakers, he leaves us in no doubt that they exhibit a high degree of intelligence and demonstrate a profound grasp of universal mathematical and geometrical principles. He exposes the hoaxers and debunkers, and enlightens us to the beautiful mathematical proportions embodied in the cereal creations and their relationships with sacred landmarks, ley lines and even the local guardian spirits. Silva taps into the "acoustical alchemy" that is integral to the shapes, and he shows how the designs have resonance with the symbols of ancient cultures and secret societies. He also investigates the theories that music and sound, light and microwave energy are involved in their creation. The humming sounds, light columns, moving lights balls and electromagnetic interference reported by many witnesses all add up to important circumstantial evidence.

But whatever the theory, the crop circles evoke a sense of beauty, harmony and wonder. They're irresistible and undeniable.

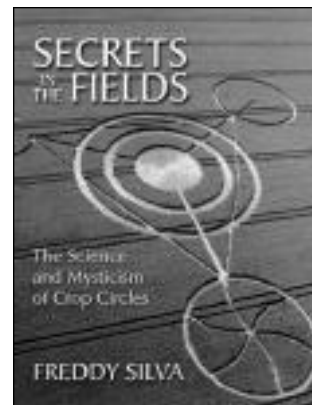



# REVIEWS

## STARGATE CHRONICLES: Memoirs of a Psychic Spy

by Joseph McMoneagle

Hampton Roads Publishing, USA, 2002  
ISBN 1-57174-265-4 (USA) (294pp hc);  
1-57175-225-5 (Aust/NZ)  
Price: A\$65.95; NZ\$83.95; £19.99;  
Euro 31,90; US\$24.95

Availability: **Australia**—Gemcraft, tel (03) 9761 5535; **NZ/UK/Europe**— NEXUS offices; **USA**—Hampton Roads Publishing, website <http://www.hrpub.com>

Joseph McMoneagle, officially designated as Remote Viewer 001 in the US military's counterintelligence program that was later called *Star Gate*, focuses on his life story in his fourth book, *The Stargate Chronicles*. For his previous ones, *Remote Viewing Secrets* (see 7/06), *The Ultimate Time Machine* (6/02) and *Mind Trek*, he covered historical aspects of the military's remote viewing (RV) programs, the strict protocols that must be followed, and even predictions for the next 100 years, but here he brings more of himself into the picture.

To date, McMoneagle has spent 23 years studying and practising RV under controlled conditions and applying it as an intelligence-gathering tool (though he left the military in 1984). He feels somewhat justified in railing against those who think they understand what remote viewing is, yet take the fast track without following and practising the tried-and-tested protocol developed at SRI in the 1970s. Yet he acknowledges that other types of psychic functioning, such as clairvoyance, can fulfill the RV protocol when everyone involved is "blind" to the object, person, place or event targeted.

McMoneagle's warts-and-all memoir includes key events in his childhood, his

military RV work, out-of-body explorations with The Monroe Institute, RVing live on TV, success in locating missing persons, and much more. He also brings a refreshing philosophical stance to his experiences, looking at the ethics of using—and misusing—psychic and RV abilities and protocols for military, political or personal ends.

## THE BEST DEMOCRACY MONEY CAN BUY

by Greg Palast

Pluto Press, UK, USA, 2002  
ISBN 0-7453-1846-0 (211pp hc)  
Price: A\$61.00 + \$5.45 p&h; NZ\$83.00 + NZ\$8.50 airmail to NZ; £18.99; £17.95 to Europe; Euro 31,90; US\$25.00

Availability: **Australia**—Footprint Books, tel +61 (0)2 9997 3973; **UK**—Pluto Press, tel 020 8348 2724, <http://www.pluto-books.com>; **Europe**—NEXUS Office; **USA**—Stylus, tel (703) 661 1581

Greedy, corruption and scandals at corporate, governmental and institutional levels have been targeted by Los Angeles-born Greg Palast since the mid-1970s. But it was not until 1998 that he decided to apply his investigative skills to journalism, first off doing undercover reporting for the London *Observer* and eventually doing exposés for BBC's *Newsnight*. He commutes between New York and London, and covers a lot of ground in between in his exposure of local and global threats to freedom.

*The Best Democracy Money Can Buy* is a compilation of Palast's essays, articles and updates on some major scandals of recent times that he's broken or reported on and which have been underplayed or ignored by the mainstream media. There's the scandal

of how the November 2000 US presidential vote was rigged in Florida, and who was paid to fix it. There's the scandal of how the IMF and World Bank forces debt-ridden Third World nations to sell out to transnationals, which then leave the poor unable to afford water. There's the scandal of how Monsanto hid crucial test data for its genetically modified milk-making hormone BST, and conspired with the FDA to have it approved. Not to mention the 1998 UK "Lobbygate" scandal, where Palast exposed the hand-in-glove relationship Labour PM Tony Blair was fostering with US Big Business interests via well-connected lobbyists. And Palast's analysis of the UK D-Notice system is revealing for what it says about journalistic self-censorship and the implications for freedom of speech.

Palast captures much more, though could have included more documentation as backup. But his writings are gripping, as he weaves his own story as a "muckraker" into the subjects with incisiveness and humour.

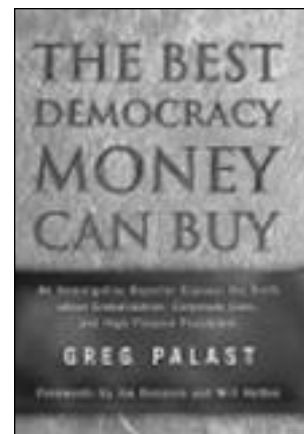

# REVIEWS



## CONVERSATIONS WITH THE BODY

by Robyn Elizabeth Welch

Hodder & Stoughton, UK, 2002

ISBN 0-340-81942-1 (212pp tpb)

Price: A\$29.95; NZ\$37.95; £10.00;

Euro 17,90

Availability: **Aust**—Hodder Headline, tel

(02) 8248 0800; **NZ**—Hodder Moa

Beckett, tel (09) 478 1000; **UK**—Hodder &

Stoughton, tel 020 78736000; **Europe**—

NEXUS Office, tel +31 (0)321 380558

Imagine that you can focus healing energy on an organ needing attention or even cut off the blood supply to a tumour. Well, you can, says Robyn Welch, and here she shows how it's possible. Although she's always had a sensitivity for life and living things, she didn't realise her gift as a diagnostic medical intuitive until she was well into her adult years. Her uterine cancer and also brain damage sustained after a car accident in her native Australia gave her the impetus.

Welch's sixth-sense technique involves being able to scan the aura of her client, see the de-energised organ or cellular structure, and literally talk with it about its state of health and then re-energise it with focused white-light healing energy. In effect, she's intuitively adopted ancient, time-honoured methods such as those used by the kahunas of Hawaii, where she's spent a lot of time.

She's come to realise that it's a fifth dimensional healing that she's able to effect, a healing which is a level above negative influences and steeped in a loving energy that even the cells and organs enjoy lapping up. Welch recounts her remarkable story in *Conversations with the Body*, and includes many life-changing encounters with clients as well as people she's met in unusual circumstances but whose health problems she's

identified and healed. Her positive attitude to life's challenges has meant that whenever she's been hard-pressed, her needs have always been met when she's stuck to her strength of faith in the workings of spirit. The heart turns the feeling of love into an actual healing frequency, and she's seen its benefits demonstrated time and time again.

This is such a life-affirming book, and Robyn Welch's advice is of high integrity and practicality for those prepared to direct heartfelt energy with mental discipline.

## THE BIOLOGY OF TRANSCENDENCE

by Joseph Chilton Pearce

Park Street Press, USA, 2002

ISBN 0-89281-990-1 (279pp hc)

Price: A\$49.95; NZ\$64.95; £17.99;

Euro 27,90; US\$22.00; C\$29.95

Availability: **Australia**—Gemcraft, tel (03)

9761 5535; **NZ**—Southern Publishers, tel

(09) 309 6930; **UK**—Deep Books, tel 020

8693 0234; **Europe**—NEXUS Office;

**USA**—Inner Traditions, tel (802) 767

3174, <http://www.InnerTraditions.com>

The keys to transcendence as well as the potential to fall back into fear and violence are within us all, says Joseph Chilton Pearce (*The Crack in the Cosmic Egg*). But as he sees it, we are programmed to transcend and integrate the highest ideals and natures embodied in such great masters as Jesus, Buddha and Lao-tzu. So what's hindering our evolutionary progress? Pearce argues that the dictates of myth, religion and culture break down the dynamic interaction between our "head brain", or intellect, and our "heart brain", or intelligence. This breakdown keeps us locked into cycles of hurt and violence in our societies.

In *The Biology of Transcendence*, Pearce provides a "blueprint of the human spirit" that has much in common with ancient Indian yogic science teachings. Actually, many of today's frontier-pushing neuroscientists are coming to the same conclusions as the ancients about the nature of intellect and intelligence. He reminds us that as evolving beings we are capable of much more than the world's religious institutions will ever admit—for spiritual growth is not dependent on one's having a religion.

Acknowledging the input of the Heart-Math Institute as well as the Siddha Yoga Foundation, Pearce makes us face up to moving beyond our fears to incorporate an understanding of how the heart—with its electromagnetic, neural and hormonal layers—acts as our fifth brain, capable of working in partnership with our intellect and propelling us into realms of higher wisdom through love, if we so choose. This is the great adventure for humanity—and one that Pearce thinks we must undertake for the sake of our survival.

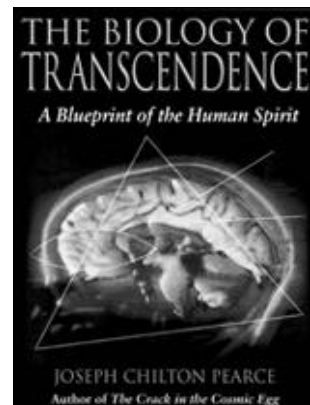



# REVIEWS

## EVIDENCE: The Case for NASA UFOs by David Sereda

Terra Entertainment, Inc., USA, 2002  
ISBN 0-75284-6353 (336pp hc)  
Price: US\$14.95 + s&h; C\$20.95 + s&h;  
Euro 18,90

Availability: **USA**—Terra Entertainment,  
<http://www.shopterra.com>; Adventures  
Unlimited; **Europe**—NEXUS Office

Readers may recall that back in 8/01 we reviewed a video, *The Secret NASA Transmissions*, that featured amazing NASA space shuttle footage recorded by Martyn Stubbs, former program manager of a Canadian cable TV station. It depicted what appear to be "life forms" which come and go in the near-space region of Earth.

As it turns out, American ufologist David Sereda has been conducting research into these phenomena and has written this book, *Evidence: The Case for NASA UFOs* (there are also two videos available, hosted by actor/filmmaker Dan Aykroyd who also wrote the foreword for the book). It was six years in the making from the time he heard about these unexplained lights and disc-shaped objects and made contact with Stubbs—who, as the story goes, kept his best footage hidden for another four years.

On the video I've seen, there were objects filmed leaving the Earth's atmosphere at extraordinarily fast speeds and impossible trajectories, as well as lights interacting with the astronauts. But as for the anomalous images in the space tether incident, Sereda concludes they were hardly specks of dust on the camera lens; in relation to the 12-mile-long tether, they were disc-shaped objects as wide as two to three miles!

With Stubbs, Sereda takes us through the various sequences and accompanying NASA

denials as to what the images portray. There's also discussion of the UV photographs, taken many years ago by NASA's Dr Louis A. Frank, of huge water balls, weighing as much as 20 to 40 tons, which hit the Earth's upper atmosphere at the rate of 10 to 20 million per year, yet appear to be intelligently guided. Something's going on out there that our scientists can't explain.

Sereda takes a giant leap by suggesting that the Sirius system is involved in many of these phenomena and that NASA is covering up what it knows. In any case, the mysteries are still unsolved, but it remains to be seen whether Sereda's speculations are correct.

## LOOKING FOR ORTHON

by Colin Bennett

Paraview Press, USA, 2001  
ISBN 1-931044-32-5 (224pp tpb)  
Price: US\$15.95 + \$2.50 s&h in US;  
£12.50; Euro 24,90

Availability: **USA**—Paraview Press, tel  
(212) 489 5343, <http://www.paraview-press.com>; **UK**—Amazon, <http://www.amazon.co.uk>; **Europe**—NEXUS Office

It's a big ask to have us believe that George Adamski's claimed encounter with a long-blond-haired Venusian in the Nevada desert in November 1952 changed the world, but this is what English author Colin Bennett says in *Looking for Orthon* (Orthon was the Venusian entity). This is despite his saying that Adamski was *not* the first such ET contactee. Even so, we can't ignore the context of the UFO phenomenon in the early 1950s, and the lasting imprint that Adamski's photographs have had on our collective psyche.

This is not the first book written about this rather curious personality, a rough diamond as well as student and teacher of esoteric

knowledge sourced from Theosophy and Anthroposophy. Adamski was born in Poland in 1891 and was only two years old when his family migrated to the USA. From 1940 he lived near the foot of Mount Palomar, California, site of the renowned 200-inch optical telescope. As well as giving lectures, living at a pioneering commune and being a local identity at the mountain's tourist haunts, Adamski scanned the skies with his own six-inch telescope and took many photographs suggestive of UFO craft (no examples are included herein, unfortunately). He also wrote several books about universal philosophy and his strange encounters, including his 1936 *Wisdom of the Masters of the Far East* and his 1953 bestseller *Flying Saucers Have Landed*.

Colin Bennett is a staunch advocate for Adamski's importance in setting the philosophical tone for the postwar UFO period. But his comparisons of Adamski's role with that of famous historical figures like Pythagoras, Shakespeare and Hitler detracts from what is already a captivating story.

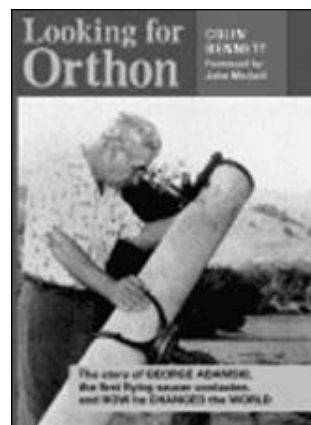

# REVIEWS



## THE ROUND TOWERS OF ATLANTIS by Henry O'Brien

Adventures Unlimited Press, USA, 2002  
(first published as *The Round Towers of Ireland*, 1834)

ISBN 1-931882-01-0 (524pp tpb)

Price: A\$39.00; NZ\$49.00; £16.95;

Euro 24,90; US\$18.95 + s&h

Availability: **Aust/NZ/UK/Europe—**

**NEXUS** offices; **USA—**Adventures Unlimited, tel (815) 253 6390, website <http://www.adventuresunlimitedpress.com>



**W**ho built the Round Towers of Ireland and for what purpose remains a mystery. According to Irish tradition they were built by the ancient Tuatha de Danann, said to have been led to Ireland from the Holy Land by Queen Scota; so they are probably pre-Christian. They certainly caught the attention of one Henry O'Brien, who was born in County Kerry, Ireland, in 1808 and graduated from Trinity College, Dublin.

O'Brien applied his linguistic ability and

interest in archaeology, history and ancient traditions to his major work, *The Round Towers of Ireland*, which was published in 1834—but his sudden death the next year, aged 27, deprived the world of a visionary scholar. This edition is a faithful reprint of the original, though the publisher strangely substitutes Ireland with Atlantis in the title. O'Brien discusses the fascinating connections that ancient Ireland had with India, Persia and China and he compares the round towers with the Egyptian obelisks. The language, being of the early 19th century, requires patience in the reading, but the text is full of arcane knowledge that crosses historical, religious and cultural borders.

The introduction (in inappropriately small type) is by David H. Childress, who refers to the work of Dr Phil Callahan who first studied the towers when he was stationed in Ireland during World War II as a US Army radio engineer. While one theory posits that the towers had an astronomical purpose, Dr Callahan surmises that each tower was built to act as an antenna, in concert with a nearby paramagnetic crystalline rock outcrop, to focus the Sun's energy into the ground to aid soil and plant fertility. This treasure trove of esoterica expands on the mystery.

## BEFORE THE FLOOD by Ian Wilson

Orion Books Ltd, UK, 2001

ISBN 0-75284-6353 (336pp hc)

Price: A\$49.95; NZ\$79.95; £18.99;

Euro 33,90; US\$ n/a

Availability: **Australia—**Allen & Unwin,

tel (02) 8425 0100; **NZ—**Hodder Moa

Beckett, tel (09) 377 3800; **UK—**Orion

Books, tel 020 7240 3444; **Europe—**

**NEXUS** Office, tel +31 (0)321 380558;

**USA—**St Martin's Press (early 2003), tel (212) 674 5151, <http://www.stmartins.com>

**T**he evidence has been growing for decades that the Black Sea was once breached and flooded by the Mediterranean Sea at the area known as the Bosphorus. Historian Ian Wilson (*The Blood and the Shroud*) has been following the discoveries, especially those made by US oceanographer Bill Ryan and plate tectonics specialist Walter Pitman in 1993, confirming a 1970s Bulgarian mapping of an ancient shoreline 100 metres below the present sea level.

Ryan and Pitman, with geology student Candace Major, found in their core samples the remains of freshwater mussels that could only have been smashed up in a devastating rushing-in of salt water; they were later dated to c. 5600 BC. Their findings, which they discussed in their 1998 book *Noah's Flood*, give credence to the various Great Flood legends sourced from this region, and even to the Atlantis myth. But it wasn't until September 2000, during American Robert Ballard's second expedition to the Black Sea, that remains of wooden dwellings were found, 15 km offshore from Sinop in northern Turkey and 95 metres underwater.

The threads of this story are up-ending what we understand of post-Ice Age civilisations, landscapes and climates. In *Before the Flood*, Ian Wilson speculates on the people and culture of the Black Sea region before the inundation, and their possible links with the ancient inland centre of Çatal Hüyük (in Turkey) and a religion based on Great Mother Goddess worship. And because many cultures have bordered the Black Sea, the rewards of future expeditions will undoubtedly be rich. Wilson's enticing book conjures some dramatic moments.



# REVIEWS

## UFOs AND THE NATIONAL SECURITY STATE: Chronology of a Cover-up 1941-1973

by Richard M. Dolan

Hampton Roads Publishing, USA, 2002 (revised edition; first published 2000)  
ISBN 1-57174-317-0 (478pp tpb)  
Price: A\$41.95; NZ\$53.95; Euro 20,90; £13.99; US\$15.95 (US\$11.95 on the web)  
Availability: **Aust**—Gemcraft, tel (03) 9761 5535; **NZ**—NEXUS Office, tel (09) 405 1963; **Europe**—NEXUS Office, tel +31 (0)321 380558; **UK**—Airlift Book Co., tel 020 8804 0400; **USA**—Hampton Roads Publishing, tel (804) 296 2772

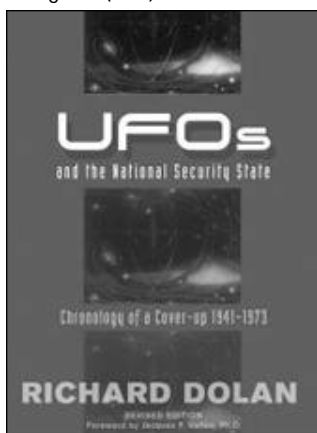

No serious study of the paranoid Cold War environment can ignore the influence of the UFO phenomenon on the establishment and evolution of the national security state, most evidently in the USA. At least one researcher, cultural historian Richard Dolan, has made the connection: that the secrecy policies and security measures put in place by government, military and intelligence apparatuses were at least partly in response to a perceived UFO threat, whether Soviet or extraterrestrial—more so than is generally acknowledged.

For the first volume of *UFOs and the National Security State*, Dolan turns to files released under the Freedom of Information Act (but as many a researcher has found, only so much material has been de-classified). To fill in the gaps, he defers to important "primary sources", such as the works of pioneering researcher/author Major Donald Keyhoe, in tracing historical developments on UFOs from the US perspective.

The scope of this volume (first published in 2000 by Keyhole Publishing and revised and updated for this new edition) covers the period from 1941, with the first "foo fighter" encounters during WWII, to 1973, by which time the UFO problem had reached new depths of security secrecy.

Dolan has written a succinct chronological

overview of postwar official and public reactions to UFOs. He covers significant sightings and "waves", attempts by the military to clamp down on a possible security threat it couldn't control, the Air Force's failed *Project Blue Book*, the beginning of the "modern" alien abduction era in 1961, and the rise and fall of early civilian UFO groups. He also examines the 1968 Condon Report, which concluded that nothing of scientific value had been or would be obtained by studying the phenomenon!

Dolan's ambitious volume is another welcome addition to the ufological record.

## THE WILD GENIE: The Healing Power of Menstruation

by Alexandra Pope

Sally Milner Publishing, Australia, 2001  
ISBN 1-86351-279-9 (288pp tpb)  
Price: A\$34.95; NZ\$49.95; £13.95; Euro 25,90; US\$/n/a

Availability: **Aust**—Gemcraft, tel (03) 9761 5535; **NZ**—David Bateman, tel (09) 415 7664; **UK**—Windsor Books, tel 01865 361122; **Europe**—NEXUS Office; **USA**—Sterling Publishing, tel (212) 532 7160

The last thing that many premenstrual or menstruating women and girls want to hear is that menstruation means living their feminine power—especially when they're in an irritable state of mind or extreme pain. But in *The Wild Genie*, Sydney-based psychotherapist and women's health educator Alexandra Pope offers a different perspective on this natural female biological cycle.

The big message is that women are *not* meant to suffer because of menstruation—but if they do, they *can* do something about it. Distressing symptoms are a signal for women to attend to their overall health and their place in the world, says Pope. By dealing with one problem at a time—for instance, improving a poor diet, restoring an imbalance of hormones, reducing stress levels, lowering exposure to environmental pollutants, and so on—women can start the healing process in motion. And as all systems are interconnected, a gain in one area soon has benefits in other areas. This does wonders for improving self-esteem, too.

Pope goes further to restore meaning to the purpose and power of the menstrual cycle, a meaning that has been devalued by materialistic culture.

She helps girls and women find a way to discover or reconnect with their innate feminine power, to work through pain and trauma via a womb-heart-head connection, and to adopt practical, health-promoting diet and lifestyle options. Her book is a well of wisdom for women of all ages—and the men who care about them.

# REVIEWS



## BATTLING BIG BUSINESS

edited by Eveline Lubbers

Scribe Publications, Australia, 2002;

Common Courage Press, USA, 2002

ISBN 0-908011-77-6 (Scribe);

1-56751-224-0 (CCP) (224pp tpb)

Price: A\$27.50; NZ\$34.95; £10.95;

Euro 22,90; US\$13.46 + s&h

Availability: **Aust**—Scribe Publications, tel (03) 9349 5955, website

<http://www.scribepub.com.au>; **NZ**—

Addenda, tel (09) 834 5511; **UK**—Green

Books, tel 01803 863260; **Europe**—

NEXUS Office; **USA**—Common Courage

Press, tel (207) 525 0900, website

<http://www.commoncouragepress.com>



This is an important book about corporate tactics of greenwashing, infiltration and other forms of bullying—and how to counteract them. It is edited by Dutch grassroots activist Eveline Lubbers, who commissioned some well-known writers and campaigners around the world to contribute.

In the first part, the emphasis is on how powerful corporations try to silence their critics and "keep up appearances" by using public relations tactics to bolster their ethical and environmental profile, while hiding the true harm that their products and practices may be wreaking on the environment and people, both in the developed and developing worlds. Represented are industries including oil (Shell and bp), "life sciences" (Monsanto), forestry (Timberlands), tobacco and food (Philip Morris/Kraft) and fast food (McDonald's). Their strategies include rebranding themselves, forming front groups to masquerade as citizens' organisations, co-opting their critics by hiring high-profile environmentalists, adopting divide-and-rule policies, targeting classrooms, spying on critics and suing them for libel, lobbying stakeholders and governments behind the scenes, cyber-surveillance, and so on.

The focus in the second part is on how the concerned citizen can battle big business bullying through patient investigation, Internet activism, non-violent protest and

specially targeted grassroots actions.

The high-calibre contributors include Sharon Beder (*Global Spin*, see 7/04), Ann Doherty and Olivier Hoedeman (Corporate Europe Observatory), Nicky Hager (*Seeds of Distrust*; *Secret Power*, 3/06), George Monbiot (*Captive State*, 8/03; *Guardian*), and Eveline Lubbers herself. Whether you're fighting a supermarket chain coming to town or an engineering transnational building a pipeline in your area, this is a must-read for those who want to know what they're up against and how to overcome it.

## AIDS: A SECOND OPINION

by Gary Null, PhD

Seven Stories Press, USA, 2002

ISBN 1-58322-062-3 (750pp hc)

Price: £23.99; Euro 44,90; US\$34.95;

C\$49.95

Availability: **UK**—Turnaround, tel 0181

829 3000; **Europe**—NEXUS Office, tel +31

(0)321 380558; **USA**—Seven Stories Press,

website <http://www.sevenstories.com>;

**Canada**—Hushion House, tel (416) 285

6100

Leading American alternative health practitioner and writer Gary Null, PhD, (with editor James Feast, PhD) has produced a mega-guide to alternative, traditional and orthodox approaches to AIDS.

*AIDS: A Second Opinion* is divided into seven parts: evidence against the current AIDS hypothesis; alternative causes of AIDS; the business of AIDS, Inc.; conventional treatment programs; the AZT hoax; alternative treatments (with some age-old wisdom); and a grand finale on the increasingly popular new medical paradigm.

Dr Null analyses the science bandied about on both sides of the HIV/AIDS debate, the rubbery statistics issued by health authorities, and the African AIDS origin hypothesis in light of US anticancer and biowarfare programs, drawing here on testimony from Dr Leonard Horowitz. There's analysis of the African AIDS situation and the problem of making available cheap anti-AIDS drugs (yet ones already known by US scientists to be dangerous). The alternative therapeutic protocols covered have much going for them compared with pharmaceutical drug cocktails, and the case studies and experiences of long-term survivors suggest a paradigm shift is required in the approach to treatment.

There's a chapter on oxygen and ozone therapies, but no mention I can see of Basil Wainwright's successes against AIDS and other diseases in Kenya and elsewhere with application of his polyatomic apheresis "blood ozonation" technology. But that's not to say that the personalities and politics, the realities and deceptions in the AIDS drama are not writ large in these pages.



# REVIEWS

## VIDEO

Reviewed by Duncan Roads

### MICHAEL MOORE:

Live in Santa Rosa, March 4, 2002

© Project Censored, USA, 2002

Price: US\$20.00 inc. s&h in USA  
(70mins, NTSC)

Availability: USA—Project Censored,  
Sonoma State University, 1801 East Cotati  
Avenue, Rohnert Park, CA 94928, tel  
(707) 664 2500, website <http://www.projectcensored.org>



I get to visit the USA once or twice a year, and one thing I look for on their TV is Michael Moore's show, *The Awful Truth*. It represents the average, everyday, small, battling American having their say and fighting back against faceless and impersonal corporations and bureaucracies. And the best thing about it is: Michael Moore is *not* your typical square-jawed, clean-shaven, designer-dressed, teleprompter reader: he is just a regular American guy who gives a dam. And he is very incisive and funny, to boot.

By now, every NEXUS reader should have heard of his book that no one would publish: *Stupid White Men...and Other Sorry Excuses for the State of the Nation!* (see cover image above). This video is of a talk Mike gave to university students during his whirlwind tour following the eventual release—and surprise success—of his book.

In a very skilful and humorous way, he explores: the fact that George W. Bush hijacked the US presidential election with assistance from bro' Jeb; the cosy relationships between The Carlyle Group and the bin Ladens; and many other hypocracies not

readily evident to the American public.

I do like his declaration that Americans should leave some sort of explanation about their societal structure for future historians and archaeologists—in the sense that 1% of the nation rules the other 99%, yet those in the 99% category run around saying the USA represents freedom and democracy.

After hearing Mike speak, you feel fired up about your own power to effect change. He tells his wryly amusing story about a billboard for potato chips, writing an essay and ending up on national TV at age 16—the point being that where there's a will... This is a truly motivating and inspiring as well as informative 70 minutes that should be compulsory viewing for all Americans.

## CD-ROM

Reviewed by Duncan Roads

### SUIL'S ISLAND

by Telma G. Dufton

Price: A\$30.00 inc. p&h in Australia; o/s airmail add A\$5.00 (cheques & MOs only, payable to Telma G. Dufton)

Systems: PC, Windows and Mac

Availability: Australia—Telma G. Dufton,  
6 Sixth Avenue, Katoomba NSW 2780, tel  
+61 (0)2 4782 4686, email [c/omd@pnc.com.au](mailto:c/omd@pnc.com.au)

This CD-ROM book is the end result of nearly two decades of research into ancient history and the origins of human civilisation. Like so many books we review, this does not consider current theories of history to be sacrosanct, and thus it asks many intelligent questions and in turn provides some insightful observations.

Author Telma Dufton has certainly kept up to date with both mainstream and alternative information sources, and the scope and breadth of her material is impressive, to say the least. The subjects include: dating techniques; ley lines, maps and measurements; ancient civilisations; the Druids; planetary catastrophes and climate change; ships and navigation; and myths and religions. And on top of all this, she's crammed the CD with fascinating facts, figures, maps and diagrams. As well as being a sharp-eyed historian, Telma is an accomplished artist, having twice been a finalist in the prestigious Australian art competition, the Doug Morgan Portrait Prize. The only "complaint" I have about this book is that, since it is a CD-ROM, I cannot take it to bed to read, which is where I like to read books of this special nature!

I look forward to seeing this published as a hardback book one day; the quality of its content would certainly make it worthwhile.

# REVIEWS



## MUSIC

Reviewed by Richard Giles

### MOFFOU

by Salif Keita

Universal Music, France, 2002 (61mins)  
Distributors: **Australia/NZ/UK/USA**—  
Universal Music

The master of Malian music, Salif Keita, is back with a new album in which he returns to his roots with profound songs of freedom, joy, creativity and a sense of responsibility for nature and the environment. An assembly of local musicians backs him on this home visit. His words on the CD insert sum up the music: "Happiness isn't for tomorrow. It's not hypothetical; it starts here and now." His origins as a music man of the Griot tradition of Mali come through strongly. Melodious and relaxed listening with a great African flavour.

### DEEP SPACE

by Japetus

Japetus Music, Australia, 2001 (62mins)  
Distributor: **Australia**—Japetus, tel 0412  
041400 (mobile, Aust only), website  
<http://www.japetus.net>

Japetus has been a leading ambient and New Age musician in Australia since the 1980s. Over the last year he's been remastering and re-recording all his early works. *Deep Space* is a collage of cosmic moods that wash through you, taking the soul on a trip through universal mind. The CD is divided into two lengthy tracks: "Starlite", winner of a 2000 Dolphin Music Award, and "Celestial Ocean", which works through ebb and flow into the soul. *Deep Space* is a broad sweep, taking you on an extra-human journey, not unlike Kubrick's 2001. Very powerful and profound music.

### THE GIFT

by Hassan Hakmoun

Universal Music, UK, 2002 (51mins)  
Distributors: **Australia/NZ/UK/USA**—  
Universal Music, website  
<http://www.universalmusic.com>

Hassan Hakmoun has a Gnawa family background mixed with Berber and Arab ancestry. Gnawa music and dance is a distinct spiritual healing art derived from the Gnawa slaves brought to Morocco from Mali centuries back. In 1993 Hassan released *Trance*, his first album on the Real World label, which helped make his name. His instrument is the African bass lute, the sintir. *The Gift* is the result of sessions recorded in Morocco but mixed in the US, where the Gnawa songs were combined with reggae, pop and traditional sounds.

### RETURN TO SERENITY

by various artists

Music Mosaic, Australia, 2002 (59mins)  
Distributors: **Australia**—New World  
Music, tel (02) 9565 4522, website  
<http://www.music-mosaic.com>; **USA**—  
New Leaf Distribution, website  
<http://www.newleaf-dist.com>; **Europe**—  
Silenzio Music, <http://www.silenzio.de/>

Music Mosaic brings together sounds from around the world into theme compilations on one disc. *Return to Serenity* features 11 tracks from various international artists including Australia's Tarshito, America's Gabrielle Roth, shakuhachi player Kamal and keyboardist/programmer Ross Griggs. Sounds of the Australian outback, flute, nature and environment come together in a special mix. This is not your run-of-the-mill ambient CD, but an entrancing compilation of serene sounds for quieter moments.

### WINDSEEKER

by Tony O'Connor

Studio Horizon, Aust, 2002 (51mins)  
Distributors: **Australia**—Studio Horizon,  
tel (07) 5478 5215, website  
<http://www.tonyoconnor.com.au>; **UK**—  
New Life 2000, tel 0144 2251430;  
**USA**—Studio Horizon North, tel (909)  
302 5370

This new album by ambience maestro Tony O'Connor is an adventure into Native American flute (called the prayer flute). Inspired by the flute work of Tony Richards, he allowed the instrument to lead the way; he started early in the morning, recording, playing continuously and letting the wood do the directing. Almost all is recorded in this freeform style. Tony complements the flute sounds with acoustic guitar, percussion, bass and keyboards. There's a relaxing yet haunting resonance in *Windseeker* that works on many levels.

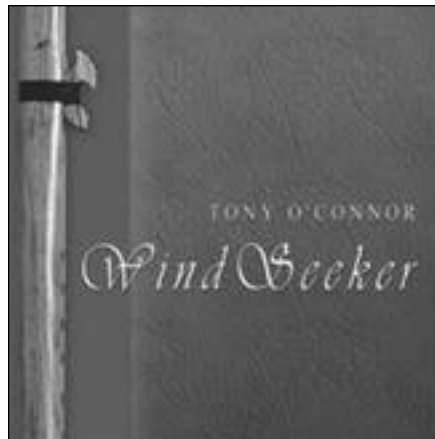

## A History of Corporate Rule and Popular Protest

Continued from page 14

- direct public discussion toward the most vulnerable link in the corporate chain of power: the legal basis of the corporation;

- internationalise the movement so that corporations cannot undermine it merely by shifting their base of operations from one country to another.

As Lawrence Goodwyn noted in his definitive work, *The Populist Moment*, the original Populists were "attempting to construct, within the framework of American capitalism, some variety of cooperative commonwealth". This was "the last substantial effort at structural alteration of hierarchical economic forms in modern America".<sup>6</sup>

In announcing the formation of the Alliance for Democracy, in an article in the August 14, 1996 issue of *The Nation*, activist Ronnie Dugger compiled a list of policy suggestions which comprise some of the core demands of the new populist movement. These include: a prohibition of contributions or any other political activity by corporations; single-payer national health insurance with automatic

universal coverage; a doubling of the minimum wage, indexed to inflation; a generic low-interest-rate national policy, entailing the abolition of the Federal Reserve System; statutory reversal of the court-made law that corporations are "persons"; establishment of a national public oil company; limitations on ownership of newspapers, magazines, radio and TV stations to one of any kind per person or owning entity; and the halving of military spending. The new populists are, in Ronnie Dugger's words, "ready to resume the cool eyeing of the corporations with a collective will to take back the powers they have seized from us".<sup>7</sup>

The new populism draws some of its inspiration from the work of the Program on Corporations, Law and Democracy (POCLAD), a populist "think-tank" that explores the legal basis of corporate power. POCLAD believes that it is possible to control—and, if necessary, dismantle—corporations by amending or revoking their charters.<sup>8</sup>

Since the largest corporations are now transnational in scope, the new populism must confront their abuses globally. The International Forum on Globalization (IFG)

was founded for this purpose in 1994, as an alliance of 60 activists, scholars, economists and writers (including Jerry Mander, Vandana Shiva, Richard Grossman, Ralph Nader, Helena Norberg-Hodge, Jeremy Rifkin and Kirkpatrick Sale), to stimulate new thinking and joint action along these lines.

In a position statement drafted in 1995, the International Forum on Globalization said that it: "...views international trade and investment agreements, including the GATT, the WTO, Maastricht and NAFTA, combined with the structural adjustment policies of the International Monetary Fund and the World Bank, to be direct stimulants to the processes that weaken democracy, create a world order in the control of transnational corporations and devastate the natural world... The IFG will study, publish and actively advocate in opposition to the current rush toward economic globalization, and will seek to reverse its direction. Simultaneously, we will advocate on behalf of a far more diversified, locally controlled, community-based economics... We believe that the creation of a more equitable economic order—based on principles of diversity,

Continued from page 80

democracy, community and ecological sustainability—will require new international agreements that place the needs of people, local economies and the natural world ahead of the interests of corporations..."<sup>9</sup>

Leaders of the new populism appear to realise that anti-corporatism is not a complete solution to the world's problems; that the necessary initial focus on corporate power must eventually be supplemented by a more general critique of centralising and unsustainable technologies, money-based economics and current nation-state governmental structures, by efforts to protect traditional cultures and ecosystems, and by a renewal of culture and spirituality.

It would be foolish to underestimate the immense challenges to the new populism from the current US administration and from the jingoistic, bellicose post-September 11 public sentiment fostered by the corporate media. Nevertheless, POCLAD, the Alliance for Democracy and the IFG (along with dozens of human rights, environmental and anti-war organisations around the world)

provide important rallying points for citizens' self-defence against tyranny in its most modern, invisible, effective and even seductive forms.

### Endnotes

1. Grossman, Richard and Frank Adams, *Taking Care of Business: Citizenship and the Charter of Incorporation*, pamphlet, 1993, available at <http://www.poclad.org/resources.html>.
2. Zinn, Howard, *A People's History of the United States: 1492 to Present*, Harper Perennial, 2001.
3. Brecher, Jeremy and Tim Costello, *Global Village or Global Pillage: Economic Reconstruction from the Bottom Up*, South End Press, 1998.
4. Zinn, op. cit.
5. Gross, Bertram, *Friendly Fascism: The New Face of Power in America*, South End Press, 1998.
6. Goodwyn, Lawrence, *The Populist Moment: A Short History of the Agrarian Revolt in America*, Oxford University Press, 1978.
7. The Alliance for Democracy website, <http://www.thealliancefordemocracy.org/>.
8. POCLAD website, <http://www.poclad.org>.
9. IFG pamphlet, 1995; revised position statement at IFG website, <http://www.ifg.org>.

### About the Author:

Richard Heinberg is a journalist, educator, editor, lecturer and musician. He has lectured widely and appeared on national radio and TV in five countries. He is a core faculty member of New College of California, where he teaches courses on Culture, Ecology and Sustainable Community.

He is the author of: *Memories and Visions of Paradise*; *Celebrate the Solstice*; *A New Covenant with Nature*; and *Cloning the Buddha: the Moral Impact of Biotechnology*. His next book, *The Party's Over: Oil, War and the Fate of Industrial Societies*, is to be published by New Society in March 2003. His essays have been featured in *The Futurist*, *Intuition*, *Brain/Mind Bulletin*, *Magical Blend*, *New Dawn* and elsewhere.

Richard is also author/editor/publisher of *MuseLetter*, a highly regarded monthly, subscription-only, alternative newsletter which is now in its tenth year of publication. *MuseLetter's* purpose is "to offer a continuing critique of corporate-capitalist industrial civilization and a re-visioning of humanity's prospects for the next millennium". His article, "A History of Corporate Rule and Popular Protest", was originally published in *MuseLetter* in 1996 as "The New Populism", and was revised in August 2002. Visit the *MuseLetter* website at <http://www.museletter.com>.

## Ultrasound Scans: Not so Safe and Sound

### Continued from page 20

- Kieler H, Ahlsten G, Haguland B et al. Routine ultrasound screening in pregnancy and the children's subsequent neurological development. *Obstet. Gynecol.* 1998, vol. 91, no. 5 (pt 1), pp. 750-6.
- Luck CA. Value of routine ultrasound scanning at 19 weeks: a four year study of 8849 deliveries. *Br. Med. Journal* 1992, vol. 34, no. 6840, pp. 1474-8.
- Liebeskind D, Bases R, Elequin F et al. Diagnostic ultrasound: effects on the DNA and growth patterns of animal cells. *Radiology* 1979, 13(1):177-184.
- Lorenz RP, Comstock CH, Bottoms SF, Marx SR. Randomised prospective trial comparing ultrasonography and pelvic examination for preterm labor surveillance. *Am. J. Obstet. Gynecol.* 1990, vol. 162, no. 6, pp. 1603-1610.
- Marinac-Dabic D, Krulewitch CJ, Moore RM, Jr. The safety of prenatal ultrasound exposure in human studies. *Epidemiology* 2002 May 13 (3 Suppl):S19-22.
- Meire HB. The safety of diagnostic ultrasound (commentary). *Br. J. Obstet. Gynaecol.* 1987, vol. 94, pp. 1121-1122.
- MIDIRS. Informed Choice for Professionals, leaflet no. 3. Ultrasound screening in the first half of pregnancy: is it useful for everyone? MIDIRS and the NHS Centre for Reviews and Dissemination, 1996.
- Mole R. Possible hazards of imaging and Doppler ultrasound in obstetrics. *Birth* 1986, 13:329-37.
- *New Scientist*. Shadow of doubt. 12 June 1999.
- Neilson JP. Ultrasound for fetal assessment in early pregnancy (Cochrane Review). In: *The Cochrane Library*, Oxford, Update Software, issue 2, 2002.
- Newnham J, Evans SF, Michael CA et al. Effects of frequent ultrasound during pregnancy: a randomised controlled trial. *Lancet* 1993, 342(8876):887-91.
- Newnham JP et al. Doppler flow velocity wave form analysis in high risk pregnancies: a randomised controlled trial. *Br. J. Obstet. Gynaecol.* 1991, vol. 98, no. 10, pp. 956-963.
- Oakley Ann. The history of ultrasonography in obstetrics. *Birth* 1986, vol. 13, no. 1, pp. 8-13.
- Odent M. Where does handedness come from? *Primal Health Research Quarterly* 1998, 6(1).
- Olsen O et al. Routine ultrasound dating has not been shown to be more accurate than the calendar method. *Br. J. Obstet. Gynaecol.* 1997, vol. 104, no. 11, pp. 1221-2.
- Rothman, Barbara Katz. *The Tentative Pregnancy: Amniocentesis and the Sexual Politics of Motherhood*. Pandora, 1994, 2nd edition.
- Saari-Kemppainen A, Karjalainen O, Ylostalo P et al. Ultrasound screening and perinatal mortality: controlled trial of systematic one-stage screening in pregnancy. The Helsinki ultrasound trial. *Lancet* 1990, vol. 336, no. 8712, pp. 387-391.
- Salvesen KA, Bakketeg LS, Eik-nes SH et al. Routine ultrasonography *in utero* and school performance at age 8-9 years. *Lancet* 1992, vol. 339, no. 8785, pp. 85-89.
- Salvesen KA, Vatten LJ, Eik-nes SH et al. Routine ultrasonography *in utero* and subsequent handedness and neurological development. *BMJ* 1993, vol. 307, no. 6897, pp. 159-64.
- Salvesen KA, Eik-nes SH et al. Ultrasound during pregnancy and subsequent childhood non-right-handedness - a meta-analysis. *Ultrasound Obstet. Gynecol.* 1999, 13(4):241-6.
- Sparling JW, Seeds JW, Farran DC. The relationship of obstetric ultrasound to parent and infant behavior. *Obstet. Gynecol.* 1988, 72(6):902-7.
- Senate Community Affairs Reference Committee. *Rocking the Cradle: A Report into Childbirth Procedures*. Commonwealth of Australia, 1999.
- Stark CR, Orleans M, Havercamp AD et al. Short and long term risks after exposure to diagnostic ultrasound *in utero*. *Obstet. Gynecol.* 1984, 63:194-200.
- Taylor KJW. A prudent approach to ultrasound imaging of the fetus and newborn. *Birth* 1990, vol. 17, no. 4, pp. 218-223.
- Testart J, Thebalt A, Souderis E, Frydman R. Premature ovulation after ovarian ultrasonography. *Br. J. Obstet. Gynaecol.* 1982, 89(9):694-700.
- Thacker SB. Quality of controlled clinical trials. The case of imaging ultrasound in obstetrics: a review. *Br. J. Obstet. Gynaecol.* 1985, vol. 92, no. 5, pp. 437-444.
- Wagner M. Ultrasound: More harm than good? *Mothering* magazine, Winter 1995.
- Watkins D. An alternative to termination of pregnancy. *The Practitioner* 1989, vol. 233, no. 1472, pp. 990, 992.

### About the Author:

Sarah J. Buckley is a New Zealand-trained GP and an internationally published writer and advocate for gentle choices in pregnancy, birth and parenting. Sarah lives in Brisbane, Australia, with her husband Nicholas and is currently full-time mother to Emma (11), Zoe (9), Jacob (7) and Maia Rose (2), all born at home.

## Death by Doctoring

Continued from page 37

### Author's Note:

For a list of practising clinicians or to comment on this report, please telephone Steven Ransom or email [steve1@onetel.net.uk](mailto:steve1@onetel.net.uk). The views of those readers with medical qualifications are especially welcome. Thank you for reading. For re-publication details or further information, telephone +44 (0)1622 832386 or mobile 7947 496488 (UK only).

### Endnotes

18. Diamond, John, 'C': *Because Cowards Get Cancer Too*, Vermilion Press, 1999.
19. Diamond, John, "Quacks on the Rack", *Observer*, December 3, 2000.
20. Griffin, G. Edward, *World Without Cancer: The Story of Vitamin B17*, American Media Publications, 1974, 1996.
21. Day, Phillip (compiler), *B17 Metabolic Therapy – In the Prevention and Control of Cancer*, Credence Publications, 2001.
22. Day, Phillip, *Cancer: Why We're Still Dying To Know The Truth*, Credence Publications, 2000.
23. *ibid.*
24. Moss, Ralph, *The Cancer Syndrome*, Grove Press, 1980.
25. Griffin, *ibid.*
26. *ibid.*
27. Rattigan, Pat, "The Cancer Business", <http://www.vegan.swinternet.co.uk/articles/heath/cancerbusiness.html>.
28. BBC News, "Cyanide Targets Cancer", Report at [http://news.bbc.co.uk/1/hi/english/in\\_depth/sci\\_tech/2000/festival\\_of\\_science/newsid\\_913000/913463.stm](http://news.bbc.co.uk/1/hi/english/in_depth/sci_tech/2000/festival_of_science/newsid_913000/913463.stm).
29. Day, *Cancer: Why We're...*, *ibid.*
30. Phillip's testimony, on file at Credence Publications.
31. Diamond, 'C': *Because Cowards...*, *ibid.*
32. Krebs, Ernst T., *Nutritional and Therapeutic Implications*, John Beard Memorial Foundation, 1964 (privately published).
33. William's testimony, on file at Credence Publications.
34. Stefansson, Vilhjalmur, *Cancer: Disease of Civilization? An Anthropological and Historical Study*, Hill & Wang, New York, 1960.
35. Berglas, Dr Alexander, *Preface to Cancer: Nature, Cause and Cure*, Pasteur Institute, Paris, 1957.
36. Griffin, *ibid.*
37. Flora's testimony, on file at Credence Publications.
38. Day, *Cancer: Why We're...*, *ibid.*
39. See <http://www.access2wealth.com/health/reportSave%20a%20Woman's%20Life.htm>.
40. *ibid.*
41. *ibid.*
42. Hazel's testimony, on file at Credence Publications.
43. From author's interview/correspondence with Dr Nicola Hembry, on file at Credence Publications.

### About the Author:

Steven Ransom is Research Director of UK-based Credence Publications, which investigates business and governmental health fraud and provides unbiased, life-saving health information (see website <http://www.credence.org>). He is the author of *Plague, Pestilence and the Pursuit of Power: The Politics of Global Disease* (Credence, 2001), and co-author (with Phillip Day) of *World Without AIDS* (Credence, 2000). His new book, *Great News on Cancer in the 21st Century* (from which his "Death by Doctoring" article is extracted), is available at <http://www.credence.org/greatnews/greatnews.htm>. His article, "Population and Food Control: The Corporate Agenda", was published in NEXUS 9/03. Steven can be emailed at [steve1@onetel.net.uk](mailto:steve1@onetel.net.uk). Visit his own website at <http://www.whatareweswallowing.com>.