

The world's No.1 magazine for alternative news, health, future science and the unexplained

NEXUS

October–November 2011

NEW TIMES

Vol. 18, No. 6

Libya: uprising or invasion?

AUSTRALIA (inc GST)	\$7.95
NZ (inc GST)	NZD \$7.95
UK	£4.25
EU	€4.95

Flu pandemics: the TB connection

Treaty to ban space-based weapons

Breakthrough in early cancer detection

Muscle Testing explained

New science meets ancient wisdom

Crop circles: the 2011 harvest

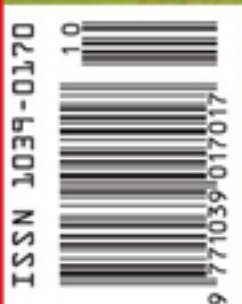

NEXUS

NEW TIMES MAGAZINE

Volume 18, Number 6
PO Box 30, Mapleton Qld 4560, Australia

OCTOBER – NOVEMBER 2011
Website: <http://www.nexusmagazine.com>

CONTENTS

LETTERS TO THE EDITOR.....4 <i>Readers comment on blackmail in science, hiatal hernia denial, nanoparticles linked to heart disruption and stroke, the suppression of breast-screening technologies other than mammography, negative ionisers and more.</i>	INVESTIGATING THE "GHOSTS OF THE OCEAN"53 <i>By Paul Stonehill. In the 1960s to 1980s, rapidly moving underwater objects and croaking sounds were reported by Soviet submariners. What was responsible: US Navy sonic buoys, crypto-creatures or unidentified objects?</i>
GLOBAL NEWS.....6 <i>We report on 3D printing technology, a European Court of Justice ruling on GM contamination, the US FDA's plan to ban dietary supplements, WikiLeaks revelations, human organs grown in the lab, Islamophobia and more.</i>	CROP CIRCLES 2011: TOWARDS A NEW ERA?.....59 <i>By Andy Thomas. This season's crop formations took a slight step back from the geometric and aesthetic heights of recent years, but still managed to surprise and put crop-watchers into suspense as to what 2012 may bring.</i>
ATLANTIC COUNCIL: LIBYA AS A "GLOBAL CON"?...11 <i>By Tony Cartalucci. The uprising in Libya is not so much a people's revolution as a terrorist-led action that's been in the making for three decades, supported by key western intelligence agencies and now NATO in collusion with corporate, financial and media interests.</i>	THE TWILIGHT ZONE.....65 <i>We feature reports on a famous UFO incident at Shag Harbour, Nova Scotia, in 1967, and on a US command sergeant major who witnessed a close encounter between UFOs and the military in 1977 and collected a metal sample bearing hieroglyphs from the crash site.</i>
INFLUENZA AND THE TB CONNECTION—Part 1.....17 <i>By Dr Lawrence Broxmeyer. An influenza virus was not the real culprit in the 1918-19 influenza pandemic. More likely, hidden tuberculosis was to blame for devastating secondary infections and the huge death toll.</i>	REVIEWS—Books.....71 <i>"Hormone Heresy" by Dr Sherrill Sellman, ND "Dirty Medicine: The Handbook" by Martin J. Walker "Pulp Med" by Petros Arguriou and Beldeu Singh "The Psilocybin Solution" by Simon G. Powell "Me-Flow" by Blake Taylor "Less Incomplete" by Sandie Gustus "UFOs: Generals, Pilots, Government Officials..." by Leslie Kean "The Extinction Protocol: 2012 and Beyond" by Alvin Conway "Manifesto for the Noosphere" by José Argüelles "The Legacy of Zecharia Sitchin" by M. J. Evans, PhD "The Sheer Ecstasy of Being a Lunatic Farmer" by Joel Salatin "Greece's 'Odious' Debt" by Jason Manolopoulos "The Most Dangerous Man in the World" by Andrew Fowler "Extreme Prejudice" by Susan Lindauer</i>
ENERGY KINESIOLOGY: BENEFITS & LIMITS.....25 <i>By Dr Steven Rochlitz. A technique developed from muscle testing may be the best modality in all of medicine for determining the optimum way to restore health, because it utilises the body's own memory and wisdom.</i>	REVIEWS—DVDs.....78 <i>"2011 NEXUS Conference" with various speakers</i>
A COSMOLOGICAL JOURNEY.....33 <i>By Dr Manjir Samanta-Laughton. This new model of the universe proposes that consciousness generates life, that black holes exist even at the subatomic level, and that light is infinite but curled up in higher dimensions.</i>	REVIEWS—Music.....79 <i>"Crystal Keys: Songs to Awaken & Heal" by Lia Scallon "Roots & Wings" by Yeshe "Cicada" by Hazmat Modine "Earth Resonances" by Thomas Chochola</i>
A TREATY FOR PEACE IN SPACE.....41 <i>By Dr Carol Rosin and co-authors. A new Outer Space Security and Development Treaty is proposed that would ban the use of weapons in space and recognise the reality of cosmic cultures and the opportunities for cooperation.</i>	NEXUS BOOKS, DVDs, ADS, SUBSCRIPTIONS.....87-96
SCIENCE NEWS.....49 <i>This edition, we cover Professor Veronica James's fibre diffraction diagnosis, a method for detecting various types of cancer, insulin dependence and Alzheimer's disease using X-rays of hair, nail clippings or skin.</i>	

NEXUS MAGAZINE

Volume 18, Number 6

OCTOBER – NOVEMBER 2011

PUBLISHED BY

NEXUS Magazine Pty Ltd, ABN 80 003 611 434

EDITOR

Duncan M. Roads
Email: editor@nexusmagazine.com

CO-EDITOR

Catherine Simons

ASSISTANT EDITOR/SUB-EDITOR

Ruth Parnell

OFFICE ADMIN/EDITORS' ASSISTANTS

Jenny Hawke; Susie Foster

MAIL ORDER DEPARTMENT

Richard Giles; Susie Foster

WEB MISTRESS/PROOFREADER

Jenny Hawke

CONTRIBUTORS THIS ISSUE

Tony Cartalucci; Lawrence Broxmeyer, MD;
Steven Rochlitz, PhD;
Manjir Samanta-Laughton, MBBS;
Carol Rosin, PhD, and colleagues;
Professor Veronica James;
Paul Stonehill; Andy Thomas

CARTOONS

Phil Somerville

COVER GRAPHIC

Jeff Edis, jeff_edis@hotmail.com

PRINTING

Beaudesert Times, Queensland, Australia

AUSTRALIAN DISTRIBUTION

Network Services (ACP)

HEAD OFFICE – All Correspondence

PO Box 30, Mapleton, Qld 4560, Australia.

Tel: (07) 5442 9280; Fax: (07) 5442 9381

Website: <http://www.nexusmagazine.com>

NZ OFFICE: Tel: +64 (0)9 405 1963; Email: nexusnz@xtra.co.nz

UK OFFICE: 55 Queens Rd, East Grinstead, West Sussex, RH19 1BG. nexus@ukoffice.u-net.com

EUROPE OFFICE: Postbus 10681, 1001 ER Amsterdam, The Netherlands. Email: nexus@fsf.nl

STATEMENT OF PURPOSE

NEXUS recognises that humanity is undergoing a massive transformation. With this in mind, NEXUS seeks to provide 'hard-to-get' information so as to assist people through these changes. NEXUS is not linked to any religious, philosophical or political ideology or organisation.

PERMISSION-TO-REPRODUCE POLICY

While reproduction and dissemination of the information in NEXUS is actively encouraged, anyone caught making a buck out of it, without our express permission, will be in trouble when we catch them!

Editorial

We have many interesting articles in this edition, and this time we start with Libya and some perspectives that even astute NEXUS readers may not have picked up. The "rebel uprising" in Libya was actually an initiative by *outside* forces using media manipulation to make it look as if there was a popular resistance against Colonel Gaddafi inside Libya. But there was *no* popular uprising in Libya: it was completely fabricated, right down to the stories of Gaddafi strafing people with warplanes and massacring thousands of civilians. It didn't happen. Such is the power of modern media when used against nations.

It is no surprise to NEXUS readers that the western mainstream media act as a propaganda mouthpiece for western foreign policy—right up to spreading lies about any country on demand, so as to garner western public support for attacks or invasions. But this year has seen the development of the role of the Arab media in *also* propagating lies in order to justify actions by various Arab states.

Al Jazeera is of particular interest here because it gained worldwide attention following the 9/11 attacks. The western perception was that Al Jazeera was some sort of independent Arab media source that was hostile to the West. Well, nothing could be further from the truth. Al Jazeera is owned by the state of Qatar. To be polite, Qatar is an oil-rich puppet dictatorship and was the main source of finance for the rebel invasion of Libya. It paid for Taliban and Al-Qaeda fighters to come from far and wide, spearhead the "uprising" in Libya and fight side by side with NATO forces against Gaddafi.

In order to speed up the invasion and demoralise the millions of Libyans who *opposed* the "uprising" (the media didn't tell you that 90 per cent of Libyans opposed it), Al Jazeera faked TV footage of Green Square, Tripoli. It created film sets and hired locals to yell and dance with happiness, and then sent this to the world media as "evidence" that Libyans were welcoming the rebels into their capital. Not to be outdone, the BBC joined in with its own "live" shots of Libyans dancing for joy at being liberated in Tripoli. Trouble is, the BBC was screening old film footage of a large crowd, in *India*, waving Indian flags and dressed in Indian clothing.

So why did the West attack Libya in 2011? How many of you knew of Gaddafi's determination to sever Africa's oppressive ties with western financial institutions such as the IMF and the World Bank? Gaddafi was not only in the process of creating the African Investment Bank (providing interest-free loans) and the African Monetary Fund, thus eliminating the IMF's role, he was also in the planning stages of creating a new, gold-backed African currency that would seriously weaken the US by undermining the dollar. Libya's vast crude oil reserves and fresh-water aquifers are just the icing on the cake, and go to rewarding the main participants.

Speaking of the evening news, do you ever wonder why the last item is always a cute, feel-good story? It's the "sugar coating" so that you "swallow" the message and perceptions planted in the main news stories, especially the international ones. The cute story at the end ensures that you digest the nasty-tasting news, which then goes to reinforcing the world view that you are expected to have.

One very important article in this edition is the Peace in Space Treaty initiative by Dr Carol Rosin. This is probably the most significant treaty you will ever see, and it is something you all can support and make a difference with, if you so choose. Please read the treaty, visit the website and make the choice to care enough to do something. This is literally considered the last chance that mankind will have to put this sort of treaty into place. This treaty goes further than just banning space-based weapons: it opens the way to the sort of future that every one of us wants.

Until next time...

Duncan

WARRANTY AND INDEMNITY

Advertisers upon and by lodging material with the Publisher for publication or authorising or approving of the publication of any material INDEMNIFY the Publisher and its servants and agents against all liability claims or proceedings whatsoever arising from the publication and without limiting the generality of the foregoing to indemnify each of them in relation to defamation, slander of title, breach of copyright, infringement of trademarks or names of publication titles, unfair competition or trade practices, royalties or violation of rights or privacy AND WARRANT that the material complies with all relevant laws and regulations and that its publication will not give rise to any rights against or liabilities in the Publisher, its servants or agents and in particular that nothing therein is capable of being misleading or deceptive or otherwise in breach of the Part V of the Trade Practices Act 1974. All expressions of opinion are published on the basis that they are not to be regarded as expressing the opinion of the Publisher or its servants or agents. Editorial advice is not specific and readers are advised to seek professional help for individual problems. The publisher reserves the right to refuse any advertising material for any reason. © NEXUS New Times 1987–2011

Republished plus new information - available now!

CoEvolution

One Monday in mid-February 1989, Alec Newald set off on what should have been a three-hour drive from Rotorua to Auckland in New Zealand.

He arrived in Auckland feeling tired and confused, but was even more confused to learn that Monday was now Thursday ten days later, and that he had no idea of what had happened in the meantime!

When Alec did retrieve his memories of those missing ten days, he realised his life had changed forever.

Early on in that fateful trip, while driving through a foggy mountain pass, Alec was whisked from the road by beings from an extraterrestrial civilisation.

What he learned and experienced during his stay with these friendly beings has profound implications for all of us here on Earth.

Soon after his 'return', Alec received strange visits from 'government scientists' wanting to know about his experience. Among other things, they were keen to learn what he had noticed about the capabilities of this alien race. Alec was uncooperative and soon found himself in 'hot water'.

It was obvious that these 'scientists' knew all about Alec's 'abductors' and expected they would return to Earth one day—soon.

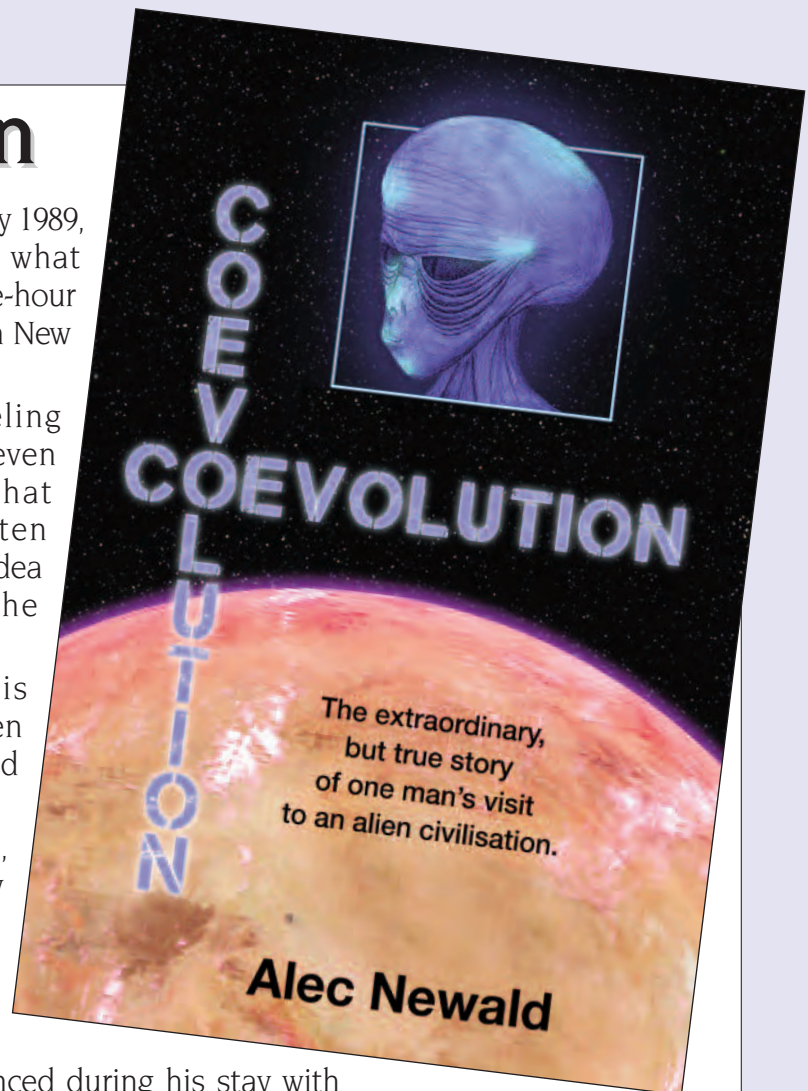

ORDER ONLINE AT
www.nexusmagazine.com

Letters to the Editor ...

Blinded by Science

Dear Duncan: If I were starring in *Criminal Minds*, I would deduce that Peter S. (your first letter last month; 18/05) is a scientist or a bureaucrat, that he does not read letters properly and almost certainly does not read NEXUS very often. My original letter was indeed on one issue, as 99 per cent of letters are.

However, I included, and you published [18/04], four other areas (astronomy, thalidomide, asbestos and cigarettes) of fake science and dodgy research over the years. How did Peter S. miss those? Or is it another case of "None so blind as those who do not wish to see"?

And how has he missed all the excellent articles and letters in NEXUS over the years showing that, from global warming to stomach ulcers, Big Pharma's drugs, fluoride in our water, full-length body-scanners at airports, aspartame, high-fructose corn syrup, mobile phone radiation, chemotherapy, vaccines, GM crops, Agent Orange, DDT and much, much more, the reports of scientists working for large corporations or paid by government (our) money are not to be trusted?

Occasionally, just as with politicians, scientists will speak the truth but, given their record, you would have to be very naive to simply trust them all.

The few scientists in the bondage of big money organisations that try to publish the truth will not

have a job for long unless their truth is in line with desired political ends and/or increased corporate sales. Science should be a hobby, unless it is honest government trying to protect us or improve our lives, which it clearly isn't (see previous lines in this letter, Mr S.).

Greetings,
Dick Barton, Dip. Nutritional Medicine and counsellor/writer, Tinahely, County Wicklow, Ireland

Blackmailed Scientists

Dear Editor: Your attitude to scientists is in my opinion quite justified [letter from Peter S., 18/05]. But how was this miserable state of affairs produced?

A year ago I had a bitter argument with a CSIRO scientist about her attitude to the current use of glyphosate (Roundup) herbicide on Queensland's tropical forest edges, creek banks, roadsides, railway reserves and even around trees on the narrow beaches and in National Parks. She told me she could not conduct any tests, as the manufacturer refuses permission.

When young scientists leave university, they have difficulty finding work. Monsanto and others offer jobs with "non-profit" organisations worldwide. To take up these jobs, applicants must sign agreements which force them to pledge not to investigate any company products without permission, for *the rest of their lives*. These companies

spend millions of dollars every year suing renegades.

In a less corrupt world, governments would indemnify scientists who tell the truth. The scientist I spoke to was frightened.

R. E. J., Australia

Edgar Steele Campaign

Mr Steele is *completely innocent*. His arrest has been orchestrated by a corrupt government via their armed police, in an attempt to silence his pointed, politically incorrect thought, research and commentary. He has become a *political prisoner*. This is a fraud, a "frame-up".

This website [<http://www.free-edgar-steele.com>] directly addresses the arrest of Edgar J. Steele [of Idaho, USA] and his evolving legal battle regarding a "murder-for-hire plot" he is alleged to have undertaken. Those involved with the content of this site have a keen interest in facts, truth, information-gathering and—ultimately—the support and complete exoneration of Mr Steele, leading to a swift release from incarceration.

In the spirit of an America conceived as a constitutional republic, endowing free speech and fair, impartial justice upon its citizens, we must all rise from the sidelines to stand with and for a fellow citizen. Many believe the America of 2010—the "great experiment in government"—has run its course and now has devolved into a

megalomaniacal oligarchy, fearful of and abusive to citizens like Mr Steele.

Free Edgar Steele website

The Vienna Declaration

To the Editor: I am writing to urge you to consider including an article on The Vienna Declaration.

The Declaration was written by organisations focused on AIDS/HIV research and social policy for the purpose of engaging the public on the need to drive drug law reform.

One can start at www.viennadeclaration.com
Best regards,
Cameron, UK

Nanoparticles and Stroke

Dear Editor: The *Daily Telegraph* [UK] reported on 2 August: "Diesel car fumes can increase risk of stroke".

Tiny particles in diesel fumes, paints, etc. can increase the risk of serious heart conditions and strokes. Some "nanoparticles" can disrupt the heart rhythm and interfere with electrical activity in the body. Abnormal heart rhythm is a leading cause of stroke.

Cities such as London, Oxford, Sheffield, Liverpool and Leeds routinely exceed European safety limits for particulates emitted by diesel cars. Britain has been warned that it faces a potential £300 million fine from the European Commission if pollution levels continue to breach the legal limits. The study's findings might explain why so many died in the

... more Letters to the Editor

London smogs of 1952 when airborne pollution, mostly from burning coal, choked London.

The study also tested white reflective titanium dioxide nanoparticles, used in paints and sunscreens, as well as "carbon black", extensively used in plastics, car tyres and dyes for printers and photocopiers, over eight million tonnes of which is produced worldwide each year.

Published in the journal *ACS Nano*, the study showed that carbon black, spark-generated carbon, titanium dioxide and silicon dioxide all produce a 15 per cent rise in irregular heartbeats. The research was led by Professor Reinhard Niessner of Munich Technical University, Germany.

White reflective titanium dioxide nanoparticles are also used in some beauty products such as foundation creams.

Best wishes,
A. Wills, UK

Hiatal Hernia Denial

Hi Duncan: I would like to comment on the previous issue, June–July 2011 [18/05], in particular the article about hiatal hernia (HH).

After reading it a couple of times, it dawned on me that this problem is identical to what my wife has been suffering from for the last 10 years.

So we decided to visit our GP and ask him about HH and what could be done about it.

The result was stunning in its abruptness. He

looked at me as if I had just crawled from under a rock, totally ignored the subject and without any questions or examination prescribed a medicine to settle the stomach.

This is exactly how Dr Steven Rochlitz described the medical profession's reaction! We are now looking for an holistic healer locally. Thanks for the wonderful magazine.

Regards,
Peter C., Kilcoy,
Queensland, Australia

Screening Suppression

I write to advise that Safe Breast Imaging (SBI) will cease its breast health services under duress. The decision to cease operating is necessary for the following reasons:

1. The Cancer Council advises women to have only a mammogram for breast cancer screening, and not to undertake any other form of imaging currently available commercially (see: <http://tinyurl.com/6zj544j>).

2. An order from the Therapeutic Goods Administration (TGA) to SBI to withdraw website advertising and publish a retraction on the website that they worded, for five months, and withdraw any claims or representations about what SBI says without the approval of the TGA.

The campaign being directed at Safe Breast Imaging is also being directed at other technologies offering breast imaging options to women.

Clients and supporters

are aware of the duress that SBI has been operating under for some time. Their response has been anger and indignation that women are being denied the right to choose how to safeguard their breast health.

(Forwarded by an anonymous but outraged supporter of SBI, Australia)

Small Negative Ions

Dear Mr Roads: I am a retired Dean and Professor of Nursing and Health Sciences, both in the UK and Canada. I currently have my own Health Education and Research Consultancy and I am very interested in energy medicine and preventive health care.

Recently, my interest has focused on negative ionisers that seek to redress the balance between positive and negative ions in the atmosphere to improve health.

On exploring the scientific literature, it became apparent that most negative ionisers on the market today have the ability to clean the atmosphere (rebalance the ions) because they have medium to large negative-ion molecules. However, through The Wellness Tree Group, a distributor company in the UK, I came across the Elanra.

The Elanra is a unique negative ioniser on the market. It produces small negative ions that have a biological (therapeutic) effect on health because the

molecules have the ability to move swiftly into the cellular structure, thereby releasing the oxygen required by the cells.

To test out this phenomenon, I decided to undertake a small-scale study using Live Blood Cell Analysis that would visually illustrate the biological effect of the Elanra along with any perceived benefits to the client.

Attached is a short article that illustrates our findings. Here is a quote from the conclusion:

"Respiratory disease is on the increase within all age groups in both developed and developing communities and significantly contributes to the poor quality of life and economic burden of societies.

"Fundamentally, there is an over-reliance on treatment regimes that are heavily invested in emergency care and prescribed medicines. Alternatives to this model are clearly needed.

"Through undertaking a small-scale study illustrating the visible effects the Elanra negative ioniser has on the biological terrain of individuals, we would strongly recommend such a non-invasive technology is worthy of further investigation and promoted for use in clinical and non-clinical settings."

Yours sincerely,
Professor Lynn Basford
(MA, BA [Hons], RN, NDN Cert., RNT, PWT, PG Cert.),
England, UK

THE 3D PRINTING REVOLUTION

Three-dimensional (3D) printing, or "additive manufacturing", is about to transform every single aspect of our lives.

Machines today can print objects out of almost any material—from nylon and glass to chocolate and titanium—and with any complex geometry. This is transforming not just engineering but many other fields including education, archaeology, bio-printing and even food printing. Look online and you will see thousands of objects ready to be printed on demand, from custom-shaped hearing aids to authentic-looking replicas of ancient cuneiform tablets.

Soon, anyone will be able to make complex products quickly and cheaply—which will democratise innovation and unleash human creativity. The next stage of this journey, which we are just beginning to experience, is control over the composition of such printed matter—going beyond shaping geometry to shaping the internal structure of materials—with



unprecedented fidelity.

The third episode of this journey is to be able to program these materials to function in arbitrary ways—to sense and react, to compute and behave—moving from an object's mechanical functionality to controlling how it processes information and energy. When this day arrives, you will be able to print virtually anything from a cellphone to a robot that will walk out of the printer, batteries included.

(Source: *New Scientist*, 3 August 2011, <http://tinyurl.com/4y7hx3l>)

EU COURT OPENS DOOR TO BIOTECH LIABILITY

On 6 September, the European Court of Justice paved the way for farmers and beekeepers to recoup losses when their crops or honey become contaminated from neighbouring fields of genetically modified (GM) crops.

The Court ruled that all food products containing GMOs—whether intentional or not—must undergo an approval process.

This marks a much stricter view than that being pushed by European Commissioner

for Health and Consumer Affairs, John Dalli, who wants no regulation of foods genetically contaminated "by accident"—a ludicrous idea, given that coexistence ensures genetic contamination.

At the centre of the dispute is Bavarian beekeeper Karl Heinz Bablok, who joined with several others in suing the state when its research plots of Monsanto's GM corn, MON 810, contaminated his honey.

In 2008, an administrative court in Germany banned Bablok from selling or giving away that honey. But in a bizarre turn, the Augsburg court also ruled that beekeepers have no claim to protection against the growing of GM crops. They immediately filed a new lawsuit.

Discussing the new ruling, attorneys for the beekeepers noted that they may now have "a claim for damages against a farmer if MON 810 pollen from his cultivation gets into their honey".

The new ruling will also apply to "imports containing traces of material from genetically modified crops that don't have sufficient approval within the EU", they said.

(Source: *Activist Post*, 7 September 2011, <http://tinyurl.com/6kgu7k8>)

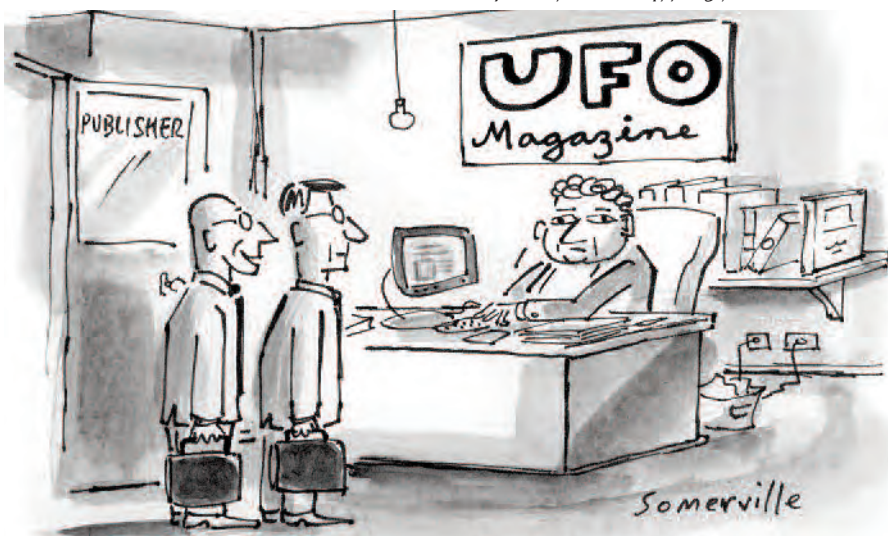

"Hi. We're from the Tax Department. We'll be abducting your account books and going over them with a special probe."

... GLOBAL NEWS ...

US FDA PLANS TO BAN DIETARY SUPPLEMENTS

The US Food and Drug Administration (FDA) has issued a proposed mandate that represents the greatest threat to dietary supplements since 1994.

Back in the early 1990s, consumers were so alarmed by FDA bullying that they staged a massive revolt. The result was that Congress passed a law prohibiting the FDA from banning popular nutrients.

There was, however, a loophole in the 1994 law. The FDA was given authority to regulate ingredients introduced after 15 October 1994.

It has been 17 years, but the FDA has just issued draconian proposals as to how it intends to regulate what it now calls "new dietary ingredients". If implemented, many of the most effective nutrients available will be removed from the market. These include many fish oil formulas and natural plant extracts.

In order for these ingredients you are using today to return to the market, the FDA will require manufacturers to conduct outrageously expensive studies using absurdly high doses, in some situations multiplied by a "safety factor" up to 2,000 times the recommended dosage on a per-product basis.

The FDA defines dietary supplements as being "new" if they were introduced after 15 October 1994. This means that even certain nutrients that have been safely used over the course of three decades will be subject to the FDA's oppressive policies that mandate costly animal testing. The FDA's new guidelines are so flawed that even nutrients shown to be completely safe in hundreds of human clinical studies would fail to accommodate the unreasonable safety margins.

For example, each manufacturer of certain fish oils would have to conduct a one-year study where animals would have to consume the

human equivalent of 240,000 milligrams of fish oil each day.

Another option under the FDA's proposed mandates is to conduct a 90-day, 1,000-fold safety margin study in which two animal species, one being non-rodent (likely, young beagle dogs), will theoretically consume the equivalent of 2.4 million milligrams of fish oil daily. We know of virtually no species that can tolerate this high dose, so, by default, FDA guidelines will make it impossible for certain omega-3 supplements to be sold.

Since these are not patented drugs, no supplement-maker will be able to afford these "safety" studies, which means that many of the nutrients you now purchase at low prices will be converted into high-priced drugs.

(Source: *Mercola.com*, 13 September 2011, <http://tinyurl.com/4237gud>)

WIKILEAKS: USA, AUSTRALIA SCHEMED AGAINST IAEA CHIEF

The United States and Australia schemed unsuccessfully in 2005 to block Mohamed ElBaradei's election to a third term as head of the International Atomic Energy Agency (IAEA), according to a newly leaked US diplomatic cable.

Both countries were unhappy with ElBaradei's "unhelpful" response to Iran's nuclear program, but the bid to prevent his re-election to the nuclear regulatory agency's leadership ultimately failed for lack of international support.

The 18 February 2005 US State Department cable released by WikiLeaks spotlights US and Australian concerns over the Egyptian diplomat's interpretation that Iran had a "right" to civilian nuclear power and his reluctance to declare Iran non-compliant with the Nuclear Non-Proliferation Treaty.

(Source: *SpaceDaily.com*, 30 August 2011, <http://tinyurl.com/6l9m746>)

HACKING THE BRAIN

Of all the storage media you use to keep information that is most important to you, your brain is by far the most complex.

Because of the immense amount of data that the human brain can hold, scientists have been attempting to crack our internal hard drive for quite some time.

By building complex models of other brains in the animal kingdom—such as those of mice, cats and primates—and then moving on to humans, researchers



... GLOBAL NEWS ...

have begun to translate the trillions of impulses that go on in our heads into readable data.

In fact, the US Defense Advanced Research Projects Agency (DARPA) is funding a US\$4.9 million program to reverse-engineer the human brain in an effort to mine its computational abilities.

Some scientists, including Ray Kurzweil of Kurzweil Technologies, see a future where nano-robots will be injected into a person's bloodstream, head straight for the brain and then monitor activity...or worse.

(Source: YahooNews, 15 August 2011, <http://tinyurl.com/3wuvy39>)

WHO OWNS YOUR GENES?

In the USA in late July, a divided appellate court upheld patents on two human genes associated with hereditary breast and ovarian cancers.

The ruling partially reverses a landmark decision by a federal district court in March 2010, which concluded that human genes cannot be patented.

The appellate court did affirm the district court's invalidation of several claims on methods for comparing two genetic sequences.

The decision allows companies

like Myriad Genetics, which controls the patents on the BRCA1 and BRCA2 genes, to exclude others from testing and conducting research on patented genes.

The Supreme Court, the court that would hear any appeal, has long held that products of nature are not patentable subject matter. A gene, even once removed from the cell, remains a product of nature. The patent-holder did not "invent" the embodied genetic information.

(Source: ACLU Blog of Rights, 30 July 2011, <http://tinyurl.com/3kbsf8m>)

SPARE BODY PARTS GROWN IN LABORATORIES

Spare parts grown in laboratories could be just a few years away as scientists discover new ways of producing organs.

They have already grown organs such as the bladder, urethra and windpipe, which have been implanted into patients during clinical trials. Now, scientists have set their sights on replicating more complicated organs, including the heart, kidneys, liver, pancreas and thymus. The advances could extend life expectancy and cut waiting times for transplants.

The developments were detailed at a conference on "rejuvenation

technologies" at Cambridge University, UK.

One of the speakers, Professor Paolo Macchiarini, of the Karolinska Institute in Sweden, told how he implanted a laboratory-grown windpipe into a man stricken by throat cancer.

Professor Doris Taylor of Minnesota University, USA, has already created a beating human heart by stripping dead cells from a donor organ and reseeded it with live ones.

(Source: The Daily Mail, UK, 5 September 2011, <http://tinyurl.com/3u393wr>)

EXERCISE WORKOUT SENT SKYSCRAPER SHAKING

Seventeen people performing a vigorous Tae Bo workout caused a resonant effect that forced the evacuation of a 39-storey South Korean skyscraper in early July.

Prime Group, owner of the Techno Mart commercial-residential high-rise in Seoul, said 17 middle-aged people were exercising when their movements set the upper floors of the tower shaking for 10 minutes.

Scientists recreated the event in the 12th-floor gym, and observed the vibrometer while performing the same kind of aerobic exercise that was performed at the time of the shaking which occurred on 5 July.

(Source: CNN.com, 19 July 2011, <http://tinyurl.com/3v095gy>)

SMART SKIN WITH ELECTRONIC "TATTOOS"

Engineers in the USA have developed a device platform that combines electronic components for sensing, medical diagnostics, communications and human-machine interfaces, all on an ultra-thin skin-like patch that mounts directly onto the skin with the ease, flexibility and comfort of a temporary tattoo.

The circuit bends, wrinkles and stretches with the mechanical properties of skin.



"Okay, we've developed legs and migrated to land
... what does the app say is next?"

Led by Professor John A. Rogers, the Lee J. Flory Founder Chair in Engineering Innovation at the University of Illinois, the researchers demonstrated their concept through a diverse array of electronic components mounted on a thin, rubbery substrate, including sensors, LEDs, transistors, radio-frequency capacitors, wireless antennas, conductive coils and solar cells for power.

The patches are initially mounted on a thin sheet of water-soluble plastic, then laminated to the skin with water—just like applying a temporary tattoo. Alternatively, the electronic components can be applied directly to a temporary tattoo itself, providing concealment for the electronics.

Next, the researchers are working to integrate the various devices mounted on the platform so that they work together as a system, rather than as individually functioning devices, and to add Wi-Fi capability.

(Source: *ScienceDaily.com*, 11 August 2011, <http://tinyurl.com/3dohz3b6>)

MANIPULATING CIRCADIAN CLOCK FOR ALL-SEASON CROPS

Yale University researchers have identified a key genetic gear that keeps the circadian clock of plants ticking—a finding that could have broad implications for global agriculture.

The circadian clock is the internal timekeeper found in almost all organisms. It helps synchronise biological processes with day and night. In plants, this clock is crucial for adjusting growth to both time and day and to the seasons.

The Yale researchers solved one of the last remaining mysteries in this process when they identified the gene *DET1* as crucial in helping to suppress expression of the evening genes in the circadian cycle.

(Source: *ScienceDaily.com*, 3 September 2011, <http://tinyurl.com/3vochgb>)

FEAR, INC.

THE ROOTS OF THE ISLAMOPHOBIA NETWORK IN AMERICA

by Jim Lobe

A small group of interconnected foundations, think-tanks, pundits and bloggers is behind the 10-year-old campaign to promote fear of Islam and Muslims in the USA, according to a major investigative report released in August by the Center for American Progress (CAP).

The 130-page report, "Fear, Inc.: The Roots of the Islamophobia Network in America", identifies seven foundations that have quietly provided a total of more than US\$42 million to key individuals and organisations that, between 2001 and 2009, spearheaded the nationwide effort.

These foundations include funders that have long been associated with the extreme right in the United States, as well as several Jewish family foundations that have supported right-wing and settler groups in Israel.

The network also includes what the report calls "misinformation experts"—including Frank Gaffney of the Center for Security Policy (CSP), Daniel Pipes of the Philadelphia-based Middle East Forum (MEF), Steven Emerson of the Investigative Project on Terrorism (IPT), David Yerushalmi of the Society of Americans for National Existence (SANE) and Robert Spencer of Stop Islamization of America (SIOA)—who are often tapped by television news networks and right-wing radio talk shows to comment on Islam and the threat it allegedly poses to US national security.

"Together, this core group of deeply intertwined individuals and organisations manufacture[s] and exaggerate[s] threats of 'creeping Sharia', Islamic domination of the West, and purported obligatory calls to violence against all non-Muslims by the Quran," according to the report.

Nonetheless, the group's messages receive wide dissemination by what the report calls an "Islamophobia echo chamber" consisting of leaders of the Christian Right, such as Franklin Graham and Pat Robertson, and some Republican politicians, such as presidential candidates Representative Michele Bachmann and former Speaker of the House of Representatives Newt Gingrich.

Other key disseminators include media figures, especially prominent hosts on the Fox News Channel and columnists in the *Washington Times* and the *National Review*, as well as grassroots groups such as ACT! For America, local "Tea Party" movements and the American Family Association, which are behind current efforts by Republican-dominated state legislatures to ban Sharia in their jurisdictions.

The report also cites the Middle East Media and Research Institute (MEMRI), a press-monitoring agency created in 1998 by former officers in the Israel Defense Forces, which translates selected items from Middle Eastern print and broadcast media as a key part of the broader network, providing it with material to bolster its claims regarding the threat posed by Islam. MEMRI, which has just been awarded a State Department contract to monitor anti-Semitism in the Arab media, has often been accused of selectively spotlighting media voices that show anti-western bias and promote extremism.

Judging by recent polls, the network has proved remarkably successful. A 2010 *Washington Post* poll showed that 49 per cent of US citizens held an unfavourable view of Islam, an increase of 10 per cent from 2002.

The report was funded by the financier George Soros's Open Society Institute (OSI).

(Source: *Inter Press Service*, 26 August 2011, <http://tinyurl.com/3smhzbx>)

UFO

SCIENCE & CONSCIOUSNESS CONFERENCE
13 INTERNATIONAL SPEAKERS

25-27 NOVEMBER 2011

JOHANNESBURG SOUTH AFRICA

PRESENTED BY MICHAEL TELLINGER

MICEAL LEDWITH
LAURA EISENHOWER
JIM MARRS
BOB DEAN
DAVID HUDSON
KERRY CASSIDY
LLOYD PYE
CLAIRE JANISCH
WILLIAM BROWN
WILLEM DE SWART
LOUISE CLAASSEN
WAYNE HERSHEL
MICHAEL TELLINGER
JAMES GILLILAND

Bookings and more info at:
www.michaeltellinger.com & www.zuluplanet.com

ATLANTIC COUNCIL IS LIBYA A “GLOBAL CON”?

The uprising in Libya is not so much a people's revolution as a terrorist-led action that's been in the making for three decades with the support of key western intelligence agencies and now NATO, in collusion with corporate and media interests.

by Tony Cartalucci ©
6 September 2011

Email: cartalucci@gmail.com

From the blogsite:
<http://tinyurl.com/3twlces>

Conflicts of Interest

The Atlantic Council claims to be a "preeminent, non partisan institution devoted to promoting transatlantic cooperation and international security".¹ It is partnered with NATO (the North Atlantic Treaty Organization) and sponsored financially by some of Wall Street and London's largest, most powerful corporate-financier interests. These include many of the Big Oil interests poised to reap a whirlwind of profits over NATO-backed regime change in Libya: namely, BP, Chevron, Exxon and Shell. They also include defence contractors already enriched by the protracted bloodshed in North Africa, including Raytheon, BAE Systems, SAAB Technologies, Lockheed Martin, Boeing, General Dynamics and Northrop Grumman.

Additionally, the world's largest banks and equity firms sponsor the Atlantic Council, including Goldman Sachs, J.P. Morgan, Deutsche Bank, Barclays Capital, The Blackstone Group, Citigroup and Credit Suisse Bank.

There is also a tremendous amount of foundation support, each with a nefarious back-story worthy of its own thorough examination, including the Carnegie Corporation of New York, the Ford Foundation and billionaire banker George Soros's Open Society Institute.

But perhaps most alarming is the Council's sponsorship by a large representation from "reputable" news and media agencies, including Thomson Reuters, Newsdesk Media, Bloomberg (which includes *Businessweek*) and Google.

Such an elaborate, full-spectrum conflict of interest should be alarming to even the most adamant supporters of the current NATO operation in Libya. We see all of the mechanics necessary to generate the justification for regime change through media, public and political channels, the military-might to carry out the war, and the corporate-financier organisations to fully manipulate and exploit the freshly installed regime, all integrated into a single organisation. Without a doubt, the Atlantic Council has pledged unwavering support for the NATO operation, with the post "Well Done, NATO!"² perhaps the most obvious indication that not only is the Council amidst an immense conflict of interest but it is committing a full range of improprieties stemming from it.³

Before moving on, it is important to understand just how illegitimate NATO is by examining the Atlantic Council partnered with it, and how the Council is tying together corporate-financier interests and NATO's military power to sell, execute and profit from regime change in Libya.

As pointed out by Color Revolutions and Geopolitics in its article "The Devil Writes a Handbook: The Responsibility to Protect"⁴, the humanitarian aspects of the Libyan operation were merely a marketing ploy for yet another poisoned agenda stemming from Wall Street and London's financial institutions.



Northrop Grumman's MQ-8 Fire Scout, an unmanned autonomous helicopter, made headlines when one was shot down over Libya on 21 June 2011.

The Atlantic Council piece then goes on to look at recent, damning evidence, publicised by *Asia Times* reporter Pepe Escobar⁷, proving that not only NATO's earlier claimed "flickers"⁸ of Al-Qaeda in Libya are indeed raging fires, but that NATO was well aware of the terroristic nature of the rebels long before even the official start of the unrest in February 2011. The article goes into this evidence in depth and concludes by saying it is a "harum-scarum scenario of NATO snookered by al-Qaida affiliates that can only please China". Atlantic Council author de Borchgrave fails entirely to provide any additional insight into Escobar's report. However, as we are about to see, if anything Escobar's statements are

understated and NATO members have been intentionally nurturing Al-Qaeda in Libya for nearly 30 years.

For nearly three decades, US and British intelligence agencies have supported terrorist organisations within Libya to wage war against Qaddafi's government. In a *Newsweek* article of 3 August 1981, titled "A Plan to Overthrow Kaddafi", it was stated:

"The details of the plan were sketchy, but it seemed to be a classic CIA destabilization campaign. One element was a 'disinformation' program designed to embarrass Kaddafi and his government. Another was the creation of a 'counter government' to challenge his claim to national leadership. A third—potentially the most risky—was an escalating paramilitary campaign, probably by disaffected Libyan nationals, to blow up bridges, conduct small-scale guerrilla operations and demonstrate that Kaddafi was opposed by an indigenous political force."⁹

Further evidence from around this period of time comes to us from the US Library of Congress, that the plan apparently went operational and the Central Intelligence Agency (CIA) trained and supported Libyan terrorists just before they attempted to assassinate Qaddafi in 1984.¹⁰ Then called the Libyan National Salvation Front, or the National Front for the Salvation

A Global Con Indeed

The above-mentioned Atlantic Council recently penned an article titled "Global Con?", within which senior globalist scribe Arnaud de Borchgrave assaults our sensibility by proposing the following question: "Were the United States, France, Britain, Belgium, Denmark, Norway, Qatar and the United Arab Emirates—the NATO-led coalition that set out to overthrow Col. Moammar Gadhafi's regime—snookered by al-Qaida?"⁵ De Borchgrave concludes that it is a preposterous scenario and indeed he is correct, though not for the reasons he proposes.

De Borchgrave begins by mentioning notorious neoconservative James Woolsey, who in the 1990s was the director of the CIA and was approached by Libya's Moammar Qaddafi for assistance against terrorists emanating from Libya's eastern city of Benghazi. Of course, Benghazi is now the current epicentre of the NATO-backed rebellion. Ironically Woolsey, claimed by de Borchgrave to be one of the leaders of a campaign "to expose a clandestine Islamist plot to bring Shariah law to America", is also one of the chief proponents of NATO's handing over of Libya to these very "Islamist" terrorists today. Woolsey is one of the signatories of a June 2011 "Open Letter to House Republicans", imploring Congress to ignore anti-war sentiments amongst their constituents and to do "more to help the Libyan opposition" which, the letter insists, "deserves our support". The letter also advises Congress not to be "held hostage" by the UN Security Council resolution authorising the military intervention in the first place, undermining the "international rule of law" that the US was supposedly enforcing.⁶

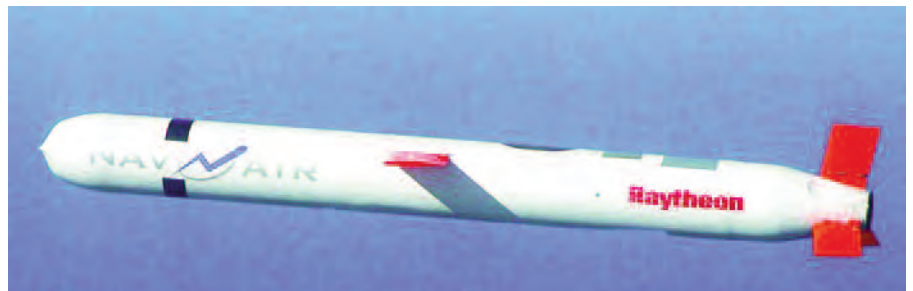

A Raytheon BGM-109 Tomahawk cruise missile, employed during the opening phases of NATO's military intervention in Libya beginning in March 2011.

of Libya (NFSL), a forerunner of the current National Conference for the Libyan Opposition (NCLC), it would grow over the years and make multiple armed attempts to seize Libya from Qaddafi with CIA and MI6 assistance.

Many of these militants would later form the Libyan Islamic Fighting Group (LIFG) in Afghanistan, also with CIA assistance under the auspices of Osama bin Laden and what would eventually become Al-Qaeda. LIFG fighters then returned to Libya and continued fighting against Qaddafi. At the outbreak of war between the US and Afghanistan, and then later with Iraq, many LIFG fighters would once again go abroad, this time to face US, not Soviet, troops. Many of these fighters are now back in Libya, after killing US and British troops, under NATO air cover, being handed piecemeal an entire nation.

West Point's Combating Terrorism Center has published two reports¹¹ detailing just how entirely Libya's eastern region is saturated with Al-Qaeda-linked terrorists, concluding that it is one of the most highly concentrated recruiting grounds for the terror organisation anywhere in the world, including Saudi Arabia. One of these reports was published in 2007, long before the current NATO operation, giving policymakers plenty of warning as to whom they would eventually be handing over the nation in 2011.

For anyone, especially NATO or the US military, to feign ignorance as to the constitution of Libya's rebel fighters is especially insulting since their entire existence is owed to 30 years of *matériel* support from western intelligence agencies and now overt military support.

Out of absolute folly, Qaddafi had invited the CIA and MI6 into Libya to help sweep up the remnants of LIFG after 2001.¹² This was under the misguided impression that Al-Qaeda constituted a common enemy between his regime and western governments. It appears that instead of helping Qaddafi fight these terrorists, they instead re-armed them, reorganised them, provided them with freshly trained recruits and sent them back into battle against Qaddafi, culminating in what we are now being told is an "indigenous uprising" by the "people" of Libya.

A Crumbling Narrative

As the depravity and duplicity of both NATO forces, overtly linked to Wall Street and London corporate-financier interests as illustrated via the Atlantic Council,

and their terrorist proxies become more apparent throughout Libya and are now creeping over the Algerian border to breathe new life into another notorious, Al-Qaeda-linked organisation, Al-Qaeda in the Islamic Maghreb (AQIM), NATO and the vast media empire supporting its agenda are seeking any and all diversions from their crumbling narrative. Lately, accusations have been levelled against China¹³ for allegedly attempting to arm Qaddafi's forces after NATO operations began in March 2011. While the West claims that this is a "violation" of their self-contrived UN mandate prohibiting the arming of belligerents in the Libyan conflict, NATO members themselves, most notably France and Qatar, have been openly supplying weapons to Libyan rebels in direct violation of this very mandate.^{14, 15}

US and UK press agencies are also attempting to muddle the debate by reintroducing the fact that the CIA and MI6 were working with Qaddafi against terrorists, now disingenuously labelled as "dissidents".¹⁶ We have even been treated to UK Prime Minister David Cameron's promise of a full inquiry after arch Al-Qaeda LIFG commander Abdul-Hakim al-Hasadi aka Balhaj demanded an apology from western security forces for torturing him after he was captured while fighting US troops in Central Asia. It should be noted that these "dissidents" are in fact fighters with the LIFG, listed by both the US State Department¹⁷ and the UK Home Office¹⁸ as a terrorist organisation; it is therefore illegal to provide them any material support at all, let alone air cover, weapons, billions of dollars in aid, and diplomatic recognition. Indeed, the Libyan conflict is a "global con".

Contrary to Atlantic Council member Arnaud de Borchgrave's suggestion that somehow the West was "snookered" by Al-Qaeda, it is NATO and its Wall Street/London big oil, military-industrial and banking interests "snookering" the world into believing that a noble military intervention is underway in Libya. The global con is that under the thin and perpetually peeling veneer of humanitarian concern lies a vicious looting spree by violent, internationally recognised terrorist mercenaries on the ground, supported by the *Fortune* 500's military might via NATO.

In addition to the windfall of profits to be made in Libya, it is specifically noted by another global corporate-financier nexus, the Brookings Institution, that the battle for Libya is being waged in order to

...it is NATO and its Wall Street/London big oil, military-industrial and banking interests "snookering" the world into believing that a noble military intervention is underway in Libya.

Well Done, NATO!

Jorge Benitez | August 24, 2011



From Julian Lindley-French, the *New Atlanticist*: NATO will soon suspend Operation Unified Protector over Libya. Nigh on ten years after 9/11 and after a gruelling decade of controversy and division the Alliance can finally chalk up an unequivocal success. The new regime in Tripoli simply would not have succeeded in toppling Gaddafi without NATO's support and I for one wish to congratulate the Secretary-General, the North Atlantic Council and Admiral Stavridis, the Supreme Allied Commander, Europe and his team for their leadership. This is t



The daily news of the world's powerful alliance.

About

Contact

Archive

Follow on Twitter: @NATOSou

I am an enormous fan of NATO use it virtually every day, because it provides a wide variety of views, a base of factual knowledge, and a touch with the world of NATO.

Admiral Jim Stavridis, SACEUR

RELATED CONTENT:

National Composition of NATO
Questions but no answers for Day 5 of NATO's Political Im

This screenshot dated 24 August 2011 shows the Atlantic Council's very premature victory congratulations extended to NATO, even as operations in Tripoli began to peter out and the full extent of the attempted psychological operation was made public (see <http://tinyurl.com/3uj3xy5>).

establish the primacy of "international law" over that of the nation-state.¹⁹ Clearly, by "international law", Brookings means the dictates proposed by think-tanks like itself or the Atlantic Council, rubber-stamped by the United Nations and pursued by an alliance driven by Wall Street and London interests. To portray a bid for global empire as a progressive humanitarian mission to alleviate unrest that they themselves created over the course of decades is indeed a "global con". ∞

About the Author:

Tony Cartalucci is a geopolitical researcher and writer based in Bangkok, Thailand. He runs an independent alternative news blog, Land Destroyer Report, which covers global geopolitics and world events from a Southeast Asian perspective. He promotes self-sufficiency and political and financial independence as the keys to true freedom. To read more of his postings, visit <http://landdestroyer.blogspot.com> and <http://landdestroyer.wordpress.com>.

Endnotes

1. <http://www.acus.org/about>
2. <http://www.acus.org/natosource/well-done-nato>
3. <http://tinyurl.com/3uj3xy5>
4. <http://tinyurl.com/3rwg2xr>
5. http://www.acus.org/new_atlanticist/global-con
6. <http://tinyurl.com/6klbbk8>
7. <http://tinyurl.com/3dzc2or>
8. <http://tinyurl.com/3o2v9cq>
9. <http://tinyurl.com/3cq9c58>
10. <http://tinyurl.com/4eyghu2>
11. <http://tinyurl.com/3t5ohch>
12. <http://tinyurl.com/446x5yn>
13. <http://tinyurl.com/3nbt03m>
14. <http://www.bbc.co.uk/news/world-africa-13955751>
15. <http://tinyurl.com/4y5rprp>
16. <http://tinyurl.com/3b3h9lj>
17. <http://www.state.gov/s/ct/rls/other/des/123085.htm>
18. <http://tinyurl.com/3g3jwv5>
19. <http://tinyurl.com/6yv93mk>

NEXUS
CONFERENCE 2011

**2011
CONFERENCE
DVDs NOW
AVAILABLE**

NEXUS
CONFERENCE 2011

ORDER VIA WWW.NEXUSMAGAZINE.COM

DANGERS OF DIRTY ELECTRICITY & EM FIELDS – DAVID STETZER

REMOTE VIEWING, PSYCHOKINETICS & LUCK CYCLES – JAMES F. COYLE

ESP, MIND CONTROL & ALCHEMY – RICHARD ALAN MILLER

TIME-TRAVELLING ETs & SELF-ACTIVATING MACHINES – LINDA MOULTON HOWE

UFO MYSTERY IN MELBOURNE – SHANE RYAN

NEW SCIENTIFIC RENAISSANCE – PROFESSOR ROBERT POPE

SACRED GEOMETRY & CONSCIOUSNESS – JONATHAN QUINTIN

SPACE WEAPONS TREATY & THE COSMIC CULTURAL CONNECTION – DR CAROL ROSIN

LIFE AFTER DEATH, LIFE BEFORE LIFE & PAST LIFE RECALL – BARRY EATON

NATURAL SOLUTIONS FOR WEIGHT LOSS – SHERRILL SELLMAN, ND

THE ASSAULT ON OUR HEALTH FREEDOM – MERYL DOREY

PROPHECIES OF BENJAMÍN PARRAVICINI – FLOR AMANOWICZ

COSMIC COINCIDENCES & 2012 – PANE ANDOV

CONVERSATIONS WITH ALIENS ON OUR HISTORY & FUTURE – ALEC NEWALD

CHANI PROJECT & SPIRITUAL AWAKENING – DUNCAN ROADS (IN PLACE OF "ACOLYTE")

NEXUS
CONFERENCE 2011

NEXUS
CONFERENCE 2011



ADVERTISE IN THE ONLINE
EDITION OF NEXUS AND
REACH A WORLDWIDE
AUDIENCE

- 
- six issues/year
 - ad sizes full page to one-ninth of a page
 - ads accepted in jpg format

FOR MORE INFORMATION,
PLEASE EMAIL
onlineads@nexusmagazine.com

INFLUENZA AND THE TUBERCULOSIS CONNECTION

**An influenza virus
was not the real
culprit in the 1918–19
flu pandemic.
More likely,
hidden tuberculosis
was to blame for
the devastating
secondary infections
and huge death toll.**

Part 1 of 2

by Lawrence Broxmeyer, MD
© 2011

The NY Institute of Medical
Research, New York, USA
Email: nyinstituteofmedical
research@yahoo.com
Website:
<http://drbroxmeyer.netfirms.com>

Several Medline studies have shown that inoculating with influenza vaccine is also protective against tuberculosis. New evidence and older historical findings which explain this phenomenon bring up the possibility that influenza doesn't originate from a virus.

How a Microbe was Repackaged and Sold as a Virus

Pfeiffer's influenza bacillus, a bacterium, was heavily isolated at one time or another in victims of the 1918–19 pandemic by practically all major research centres in the United States. It was therefore considered, by most, to be the cause of influenza until at least 1933. And Bradford, Bashford and Wilson's influenza isolates, although called "viruses" because they easily passed through a filter, were obviously minute bacteria, isolated from the blood, sputum and spinal fluid in a number of pandemic cases.¹ Bradford never named the bacteria that he and his colleagues had found. But his description of them was not inconsistent with Löhns's minute forms of the mycobacteria, the precise name originally given to Pfeiffer's influenza bacillus, which was classified *Mycobacterium influenzae* soon after its discovery. The nearest competitor of Pfeiffer's bacillus was a vague, filterable "virus".

Although the term *virus* has existed since 1898, the infectious agent it was attempting to describe was so unclear and mysterious that for many decades scientists considered it purely theoretical. Certainly, even by 1917, "influenza" was still not felt to be serious enough to be a reportable disease, and no doctor had to report it to state or local health officials. Most cases were self-limiting and gone in 10 days. Yet the great "influenza" pandemic that swept the world in 1918–19 may have been the most virulent outbreak in history, at least in terms of the swiftness of its devastation. It killed more than 20 million persons around the world, including some 550,000 in the United States—all within two years.

By 2000, Dr Andrew Noymer and Michel Garenne, demographers from the University of California, Berkeley, thought they knew just why this perceived discrepancy existed, reporting convincing statistics showing that undetected tuberculosis (TB) may have been the real killer in the 1918 flu epidemic. Aware of recent attempts to isolate the "influenza virus" from human cadavers and their specimens, Noymer and Garenne concluded: "Frustratingly, these findings have not answered the question why the 1918 virus was so virulent, nor do they offer an explanation for the unusual age profile of deaths."²

Somehow overlooked in today's revisionist history of the flu, the influenza bacillus or Pfeiffer's bacillus, discovered by Pfeiffer and Canon in 1892, was originally named *Mycobacterium influenzae* because it was thought to be related to *Mycobacterium tuberculosis*. Both mycobacteria stained best with carbolfuchsin and methylene blue—bacterial stains that Robert Koch himself used in the discovery of tuberculosis. Also, Grassberger³ observed the same branching fungal forms in Pfeiffer's influenza mycobacteria as Metchnikoff⁴

had first seen in tuberculosis. Such fungal-like forms are the hallmark of the mycobacteria (their prefix "myco" means "fungal"). Mycobacteria such as tuberculosis are particularly deadly precisely because they share properties of the fungi as well as bacteria.

More recently, in 1999, Fredj Tekaiia, of the Pasteur Institute, Paris, and colleagues, looking for "overall gene similarities as signatures of common ancestry", found similar genetic profiles and sequencing for Pfeiffer's bacillus (*Mycobacterium influenzae*) and *Mycobacterium tuberculosis*, lumping them together in the same "well-defined group".⁵ Tekaiia's diagrammatic genomic tree shows the two organisms directly next to one another. This reopened the historical argument that Pfeiffer's bacillus and tuberculosis are related.

In 1933, the very year that Smith, Andrewes and Laidlaw claimed stake to the discovery of the human influenza "virus", Stobie, in the *British Medical Journal*, still acknowledged that, rather than being a virus, the real nature of "influenza" could well be a form of *Mycobacterium tuberculosis*.⁶ Stobie simply reflected the active, vigorous, yet historically suppressed debate that had been raging in medical journals for decades. He mentions cases of tuberculosis following influenza which together exhibited "a sinister type of disease which rarely responded to treatment". Enter "galloping consumption", the most devastating form of tuberculosis, then called "consumption".

Obuchow Hospital, St Petersburg, Russia, 1890

In 1890, a fierce "influenza" pandemic struck worldwide, killing approximately a million people. Occurring at the end of the 19th century, this second most severe influenza ever to hit the world occurred at a time when there was fear that tuberculosis would destroy the civilisation of Europe.

Twenty-eight years later, those who survived that pandemic and lived to experience the Great Pandemic of 1918–19 tended to be less susceptible to the disease. But the lessons of 1890 were poorly understood and therefore not carried over to 1918.

Of all the forms of "influenza" known in 1890, none was more dreaded nor struck more terror into the hearts of victims and their families than that described by Wiltschur⁷ as "galloping consumption". An attending physician at the Obuchow Hospital, St Petersburg, Wiltschur tells what happened when influenza punctuated previous or active cases of tuberculosis: "The [influenza] patients were, for the most part, still well nourished." This mirrored the swine flu episode of

1918, where young healthy soldiers were suddenly decimated by disease. Wiltschur continued: "Cyanosis of the face and extremities was a frequent occurrence." Patients exhibited severe difficulty in breathing (dyspnoea), an extremely high temperature not characteristic of the flu, pulmonary haemorrhages and a rapid progression of lung disease, "with death occurring in many instances unexpectedly and suddenly".

Why these findings, including the well-known rapid fatality of "galloping consumption" with its high fever, profuse haemorrhaging, brownish spots or splotches on the face, strawberry tongue and typhoid-like symptoms, documented so clearly in and after the pandemic of 1890, were ignored by the historians, scientists and practitioners of 1918 is beyond comprehension.

Historian/researcher René Dubos, of the then-named Rockefeller Institute for Medical Research, would later confirm the galloping acceleration between influenza and

**Why these findings...
in and after the pandemic of
1890, were ignored by the
historians, scientists and
practitioners of 1918 is
beyond comprehension.**

tuberculosis in the laboratory.⁸ Dubos also assured us that "galloping consumption" was not an isolated, but a frequent diagnosis in the 19th century.⁹

Despite persistent myths to the contrary, in the early phase of any new TB epidemic, perhaps from a new strain, tuberculosis manifests itself as an acute disease and only much later as the chronic pulmonary tuberculosis that we know in today's western world. An example can be

found in the high mortality during the 1918 "influenza" pandemic, when African Americans were brought to fight in France during World War I, large numbers of them dying from the accelerated tubercular "galloping consumption" of yesteryear. But was it only this specific group that was affected circa 1918? There has been much documentation that in certain cases, depending on the virulence of the tubercular strain, the infection can spread rapidly, causing a disease both acute and fatal, with signs and symptoms so unspecific that a proper diagnosis is impossible to make.

College of Medicine and Surgery, Philippines, 1919

At the beginning of January 1920, an important study¹⁰ appeared in The Rockefeller Institute's *Journal of Experimental Medicine*. Physician Herbert Windsor Wade, an American investigator working out of the Department of Pathology and Bacteriology at the University of the Philippines College of Medicine and Surgery, doubted that a virus had anything to do with influenza. And Wade, working with Filipino national Dr Cristobal Manalang, proved this in 1919 in their university laboratory.

Richard Pfeiffer still insisted that his organism "had the best claim to serious consideration as the primary

etiologic agent [cause], and its only competition is an unidentified filterable virus".¹¹ Had Pfeiffer studied Wade and Manalang's laboratory evidence, his reply would have been quite different. Pfeiffer's bacillus itself had a filterable virus-like form that could easily be mistaken for a "filterable" influenza "virus".

Wade remained a voice of scientific reason throughout the 1918 influenza pandemic, during which he personally experienced a scourge in which, depending upon which province he visited, from 40 to 95 per cent of Filipinos had contracted the disease. At least 70,000–90,000 of them had already died. Wade knew what it was like to come into a village where there were not enough living to bury the dead. Also, being far from the United States, he was not subject to the relentless censorship of the Wilson administration, both against civilians and scientists of the US Army Medical Corps itself. If he saw mycobacterial forms similar to those of TB in Pfeiffer's influenza bacillus, he could and would report them without fear of being accused of fuelling the flames of hysteria. And in documenting tuberculosis-like fungal forms in previously filtered Pfeiffer's, that is exactly what Wade did.

When the French chemist/microbiologist Louis Pasteur was on his deathbed, his conscience finally overtook him, forcing him to admit that his great rival, biochemist and MD Antoine Béchamp, had been correct and that he had been wrong. Not only were microbial forms changeable, but they depended upon the culture media or the environment in the body's terrain. So with his last dying breath, Pasteur whispered: "The terrain is everything..."¹²

Nowhere else had this become more obvious than with the mycobacteria, in which, depending upon the culture media used, either fungal or bacterial elements could be grown out. Wade's media grew out fungal forms after its spores went through a filter. They were therefore "filterable", but they were not "viruses".

In the words of microbiologist Milton Wainwright, Wade and Manalang had now committed "the ultimate pleomorphist heresy",¹³ documenting that a bacterium or mycobacterium could have more than one form in its life cycle. Pfeiffer himself, when he discovered his bacillus, had seen these same forms but described them as "pseudo" influenza. Pfeiffer simply had failed to see both forms of his discovery as one and the same, central to the nature of his influenza bacillus.

It was no accident that Wade and Manalang's paper

was published by The Rockefeller Institute. Simon Flexner, then director at the Institute, once followed similar acid-fast fungal forms associated with tuberculosis and found this similar association with the influenza bacillus fascinating. Flexner called his filterable fungal forms inside TB "pseudo-tuberculosis".¹⁴

Flexner was a key figure in the 1918 pandemic, heavily influencing Rockefeller research. He also had full status in the close-knit band of major US research operatives during the pandemic. Why had he not taken the cue and run with Wade's study? Wade had found that Pfeiffer's mycobacterial fungal forms could appear as filterable viruses. Even a 1918 *British Medical Journal* editorial (1918; 2:665) had supported this.

Actually, one researcher had listened carefully to Wade. But since that researcher wasn't a member of the US scientific hierarchy, he would be ignored. His name: Dr Victor Conrad von Unruh.

Medical Reserve Corps, NYC, 1917

Physician/researcher Victor Conrad von Unruh was born in 1868 in Dahlewitz, Germany, at a time when German medical research and science were unrivalled. He immigrated to the US, and by 1917 he had received the commission of Captain in the Medical Reserve Corps, New York City. The pandemic of 1918 was about to hit hard. Von Unruh's "A Comparative Study of the Acid Fast Bacilli"¹⁵ had appeared in 1916, two years prior to the killing fields of 1918. His study can be found in the *Catalogue of the Library of The Surgeon General's Office – United States Army, 1920*—a reminder for posterity.

Because Pfeiffer's bacillus stained acid-fast, von Unruh, like others, had been evaluating what medical texts such as Stengel's¹⁶ referred to as *Mycobacterium influenzae*, also known as *Bacillus influenzae*. The entire influenza group was thought to be caused by this acid-fast mycobacterial bacillus, which was similar to the tubercle bacillus. Both microbes had fowl, swine and human forms.

Von Unruh never saw the need to look for a "filterable virus" or "influenza" in the thousands of hogs that died abruptly with flu-like symptoms just before the pandemic, as did virologist Richard Shope. Why should he? Shope, the American virologist credited with the first isolation of the influenza "virus", seemed oblivious to the fact that more than 60 per cent of hogs circa 1918 were tubercular from fowl TB, a fact that gave hog breeders such concern that large-scale efforts were under way to rid farms and chicken flocks of avian tuberculosis.

...depending upon the culture media used, either fungal or bacterial elements could be grown out. Wade's media grew out fungal forms after its spores went through a filter.

The situation had become so grave in hogs and cattle that by 1917, one year before the most destructive pandemic ever, the Cooperative State–Federal Tuberculosis Eradication Program, administered by the US Department of Agriculture and the Animal and Plant Health Inspection Service, had to be instituted. For in 1917, it was estimated that 25 per cent of deaths from tuberculosis in adult humans were caused by animal tuberculosis.¹⁷ Nor did the fact that swine freely infected humans and vice versa faze von Unruh. Swine were a mycobacterial laboratory; although they held primarily fowl tuberculosis, they could also acquire bovine and human forms and freely infect people.

In "A Comparative Study of the Acid Fast Bacilli", von Unruh stresses that the many cases of influenza he had investigated contained both the resting (dormant) form of TB and the influenza bacillus. Although Pfeiffer had likewise documented chronic colonisation with his bacillus in TB patients, von Unruh saw this, and the fact that they were both mycobacteria was more suggestive of "a common ancestry or origin". Von Unruh wrote: "We have in influenza the fever, malaise, loss of weight, invasion by the organism of the same anatomical structures as in tuberculosis; we have chronic cases of bronchitis in which the influenza bacillus is constantly present; and lastly, we know that typical tuberculosis often follows an attack, however mild, of influenza."¹⁵

Such tubercular infection could in turn lead to other secondary bacterial infections. Noymer and Garenne's statement that tuberculosis was behind the many deaths in the 1918 pandemic was specifically based upon the well-known concept that the secondary bacterial infections that cropped up in 1918 were common in TB-infected lungs. Noymer and Garenne wrote: "It is highly plausible that TB infection laid the ground for the massive secondary bacterial pneumonias that killed the victims of the flu in 1918."²

The Reichsgesundheitsamt, Berlin, March 1882

Although it has always perplexed doctors, scientists and historians alike as to why so many microbes were involved during the deadly 1918 epidemic, the explanation was laid out clearly by the German physician/microbiologist Robert Koch, discoverer of tuberculosis, decades before. From the onset, Koch concluded¹⁸ that other micro-organisms shared in the destructive work of

the tubercle bacilli. Gaffky, Pansini, Cornet, Spengler, Schabad, Ortner and Flick, among others, agreed.¹⁹

Various organisms, all of which reappeared to confuse scientists in 1918, were assigned a share in the clinical picture of tuberculosis—among them the *Streptococcus* and *Pneumococcus* micro-organisms and even the influenza bacillus itself. The pyogenic, pus-forming cocci were more generally suspected than other bacteria of complicating tuberculosis. In the *British Medical Journal* of 28 July 1900, the following editorial appeared, dealing with the role of streptococci in tuberculosis: "It is a remarkable fact that...the bulk of the disturbing and dangerous features of tuberculosis are not due to the tubercle bacillus, but to streptococci and other pyogenic organisms."

The pneumococci, staph and methicillin-resistant staph (MRSA) are other pyogenic pathogens that subsequently have been documented.

British pathologist William Crofton chafed at the ridiculous notion that in influenza, Pfeiffer's bacillus and only Pfeiffer's bacillus alone should be found in pure cultures. He asked whether the typhoid bacillus was ever found in pure culture. But because Pfeiffer's was often found with the very same infections secondary to tuberculosis, such as from streptococci and pneumococci, investigator after investigator during the Great Pandemic of 1918–19 was coming to the curious conclusion that Pfeiffer's bacillus was not the primary cause but somehow was awakened to activity by some unknown primary cause. They never for a moment considered that this unknown primary cause could be tuberculosis, which not

They never for a moment considered that this unknown primary cause could be tuberculosis, which not only spawned secondary infection with strep, staph and pneumococci but Pfeiffer's bacillus itself.

only spawned secondary infection with strep, staph and pneumococci but Pfeiffer's bacillus itself. Besides this, the obvious: microbes like streptococci, pneumococci and staphylococci could produce epidemics, but never *pandemics*. What was the source of this confusion?

Medical Reserve Corps, New York City, July 1918

Victor von Unruh continued to see many reasons to pin a common ancestry onto the two organisms. Both the influenza bacillus and the quiescent TB formed Much's granules. Much's granules, named after their discoverer, Hans Much, passed through filters—then a major criterion for diagnosing a virus. Furthermore, both the influenza bacillus and TB were mycobacteria, with the branched fungal forms characteristic of the mycobacteria. And both could stain with "acid-fast" mycobacterial stains.

Von Unruh wrote: "Therefore my conclusion is that the influenza bacillus is merely a weaker or dwarfed form of the real tubercle bacillus, a strain that in this case failed of better development because of a higher degree of resistance in the host. In both tuberculosis and influenza we deal with the self-same organism that in tuberculosis is fully developed, while in influenza it lacks development. In other words, we are dealing with a difference in degree only, but not in kind."¹⁵

Von Unruh's distinction is suggestive of a similar, well-acknowledged comparison between the damaging effects that *Mycobacterium tuberculosis* has inflicted on man for centuries and the better resistance that humans with a healthy immune system have had against bird or fowl tuberculosis (*Mycobacterium avium*), found in swine as well. Did types of fowl tuberculosis in the form of *Mycobacterium* (Haemophilus) *influenzae suis* from pigs combine additively with latent human tuberculosis to cause the deadly galloping consumption of 1918–19?

Victor von Unruh's findings could have been taken lightly, were it not for similar thoughts published in the more prestigious medical journals of his time.

Bureau of Laboratories, 1918

Something was eating at physician/researcher/editor William Park during the carnage of 1918. Park, heading the state-of-the-art Bureau of Laboratories in New York City, was relied upon by both the US Government Health Corps and other major research centres across the country. Along with collaborators, including bacteriologist Anna Williams, Park co-authored the important teaching text, *Pathogenic Microorganisms*.

At first, Park blamed Pfeiffer's bacillus for the 1918 pandemic and reported it to the US Army Health Corps. But flustered by the secondary infections and lack of consistency in other labs in isolating Pfeiffer's, Park flip-flopped, cautioning against attributing the pandemic solely to Pfeiffer's.

By the same token, Park felt uncomfortable with the muzzling of the media and medical corps by the Wilson administration regarding the ferocity of the 1918 American epidemic in general—that is, until it was too late to deny its viciousness.

So although Pfeiffer's influenza bacillus, also known as *Mycobacterium influenzae*, was no longer at the top of his choices for the causal agent of the 1918 pandemic, it was its association with another mycobacterium, tuberculosis, which bothered Park the most. He had just re-read Flick's account of what preceded both Great Pandemics.

In 1888, physician Lawrence Flick, citing US census reports leading into the two greatest world "influenza" pandemics in history, reported that out of every

1,000,000 deaths, 242,842 males and 302,046 females died of tuberculosis. This was for all nationalities and colours. Specific subsets within these statistics revealed that among African Americans, every million deaths represented 248,179 males and 326,973 females having died of tuberculosis. Among people of Irish parentage, 309,507 males and 375,636 females died of TB for every million deaths. And among people of German parentage, its victims numbered 249,498 males and 254,958 females for every one million deaths.²⁰

Although Park had seen these statistics before, their effect was not lost on him: "Consumptives [people with tuberculosis] frequently carry influenza bacilli [Pfeiffer's bacilli] for years and are particularly susceptible to attacks of influenza."²¹

In 1918, with "flu" victims dropping all around them, John B. Hawes, MD, of the Massachusetts General Hospital, and Richard Cabot, MD, of Harvard, wrote:

"One of the diseases most frequently mistaken for pulmonary tuberculosis is influenza, chronic or acute." According to Hawes and Cabot, the symptoms of both diseases were often identical.²²

Tufts pulmonologist Edward O. Otis also caught Park's attention. Otis not only mirrored Hawes and Cabot's view, he went a step further: "Often a patient gives the history of a previous attack of influenza which may have been an active outbreak of a latent tuberculous focus, which later again became inactive."²³

Back in 1901, an editorial in the *Journal of the American Medical Association* specifically cited Liverpool physician R. Buchanan: "Dr R. J. M. Buchanan makes the not improbable suggestion that many of the so-called sporadic cases of influenza are really symptomatic of the initial infection of tuberculosis, or possibly an exacerbation of a latent tuberculosis previously unsuspected or undetected."²⁴

In saying this, Buchanan had fired the shot heard around the world, and physician Walter Lindley, editor of the *Southern California Practitioner*, was quick to respond. Lindley on Buchanan: "The author, impressed by the large number of instances in which patients have referred the commencement of their ill-health to an attack of so-called influenza, conceives that many of the so-called sporadic cases of influenza are really symptomatic of the initial infection of tuberculosis or possibly an exacerbation of a latent tuberculosis."²⁵

A complaint by Wakley and Wakley in the *Lancet* in 1899 regarding an epidemic of infectious fever raging in New York is also appropriate: "The name 'influenza' seems to have a strong attraction for some people. Every ache and pain, no matter where located and whether

Did types of fowl tuberculosis...from pigs combine additively with latent human tuberculosis to cause the deadly galloping consumption of 1918–19?

accompanied by fever or not, is at once put down as 'influenza'; every headache, every coryza [nasal congestion, common cold], every sore-throat, every attack of gastroenteritis, from whatever cause, is promptly self-diagnosed as 'influenza', and when the practitioner arrives upon the scene he will be expected to fall in with this view, and there is a great temptation to do so."²⁶ The authors go on to suggest that the rise in temperature and general malaise frequently met with in this New York epidemic wasn't influenza at all.

Hendrickson, who practised during the Great Pandemic of 1918–19, spoke more bluntly: "No doubt there were many cases of tuberculosis whose death certificates were labeled influenza during the pandemic owing to lack of time to make a diagnosis by the overworked physician."²⁷

He reiterates that when an attack of influenza intervenes in a patient suffering from pulmonary tuberculosis, the tuberculosis process is likely to be aggravated "and very often terminates fatally in a comparatively short time". Of

more vital interest, even in the cases of dormant, healed TB in which the individual has contracted the disease in childhood, he quotes Osler on influenza being "an important exciting cause" of latent tuberculosis.²⁸ At the same time, Hendrickson clarifies why in certain US Army barracks in 1918, measles—in marked analogy to influenza—could also cause the reactivation and rapid spread of dormant tuberculosis.

Hendrickson, in 1918, therefore told American science all it needed to know about the pandemic, but it just wasn't listening. Epidemic measles had kicked things off in Army barracks before the influenza epidemic, during the bitterly cold winter of 1917–18. But unlike childhood measles, it was deadly, racking its victims with high fever, intractable cough, savage earaches and even brain inflammation. As with tuberculosis, the measles didn't kill by itself; rather, it killed by the very same secondary bacterial infections that dogged TB-infested lungs.

So, even prior to Pfeiffer's bacillus becoming the focus of national attention in the "influenza" epidemic, upwards of 5,000 out of approximately 30,000 barracks soldiers died of measles "complications" on American soil. At Camp Shelby, Mississippi, alone, almost half of the deaths from all reportable causes were linked to pneumonia secondary to the measles. American newspapers began to headline a measles fiasco, and Army Surgeon General William Gorgas was called to task.

Hendrickson warned American medicine that both measles and then Pfeiffer's bacillus were nothing but red herrings landing on an underlying tubercular infection. But American medicine wasn't listening.

Continued in the next issue of NEXUS...

About the Author:

Lawrence Broxmeyer, MD, is currently an internist and medical researcher. He was on staff at New York affiliate hospitals of SUNY Downstate, Cornell and New York universities for approximately 14 years. In conjunction with colleagues in San Francisco and at the University of Nebraska, he first pursued, as lead author and originator, a novel technique to kill AIDS mycobacteria and tuberculosis with outstanding results (see *The Journal of Infectious Diseases* 2002 Oct 15; 186[8]:1155-60). He contributed a chapter regarding these findings to Sleator and Hill's textbook *Patho-Biotechnology* (Landes Bio-science, 2008). He has also written many peer-reviewed articles, available on PubMed of the US National Library of Medicine – National Institutes of Health at <http://www.ncbi.nlm.nih.gov/pubmed?term=broxmeyer%20L>. Dr Broxmeyer's research covers the most challenging medical problems of our times, including AIDS and Alzheimer's disease. His two-part article "The Untold Truth About Cancer" was published in NEXUS vol. 17, nos 1 and 2.

Dr Broxmeyer can be contacted by email at nyinstituteofmedicalresearch@yahoo.com and via his website <http://drbroxmeyer.netfirms.com/>.

Endnotes

1. Bradford J.R., E.F. Bashford and J.A. Wilson, "Preliminary Report on the Presence of a 'Filter Passing' Virus in Certain Diseases", *British Medical Journal* 1919 Feb; 1:127-28, p. 128
2. Noymer A. and M. Garenne, "The 1918 influenza epidemic's effects on sex differentials in mortality in the United States", *Popul Dev Rev* 2000; 26(3):565-81
3. Grassberger R., "Zur Frage der Scheinfadenbildung bei Influnzazulturen", *Centralbl f Bakt 1 Abt* 1898; 23(9/10):353-364
4. Metchnikoff E., "Über die phagocytäre Rolle der Tuberkelriesenzellen", *Virchow's Arch f Pathol Anat* 1888; 113(1):63-94
5. Tekaiia F., A. Lazcano and B. Dujon, "The Genomic Tree as Revealed from Whole Proteome Comparisons", *Genome Research* 1999; 9:550-557
6. Stobie W., "Prognosis in Pulmonary Tuberculosis", *Br Med J* 1933 Mar 25; 1:507-509, p. 508
7. Wiltschur A.J., "Ueber den Einfluss der Gippe auf den Verlauf der Phthise und deren Krankheitsbild bei Complicationen mit Gippe", *Petersburger med Wochenschrift* 1890; XV(5)
8. Volkert, Mogens, Cynthia Pierce, Frank L. Horsfall, Jr, and René J. Dubos, "The Enhancing Effect of Concurrent Infection with Pneumotropic Viruses on Pulmonary Tuberculosis in Mice", *Journal of Experimental Medicine* 1947 Aug 31; 86(3):203-214, pp. 212-213
9. Dubos R. and Dubos J., *The White Plague: Tuberculosis, Man, and Society*, Rutgers University Press, 1987, p. 205 (first published by Little, Brown & Co., 1952)

...measles—in marked analogy to influenza—could also cause the reactivation and rapid spread of dormant tuberculosis.

Continued on page 81



Back issues are available online either as downloads or hard copies. All articles ever published in NEXUS are available as individual downloads via the website.

Use the search field to find topics of interest or click on the products tab at www.nexusmagazine.com

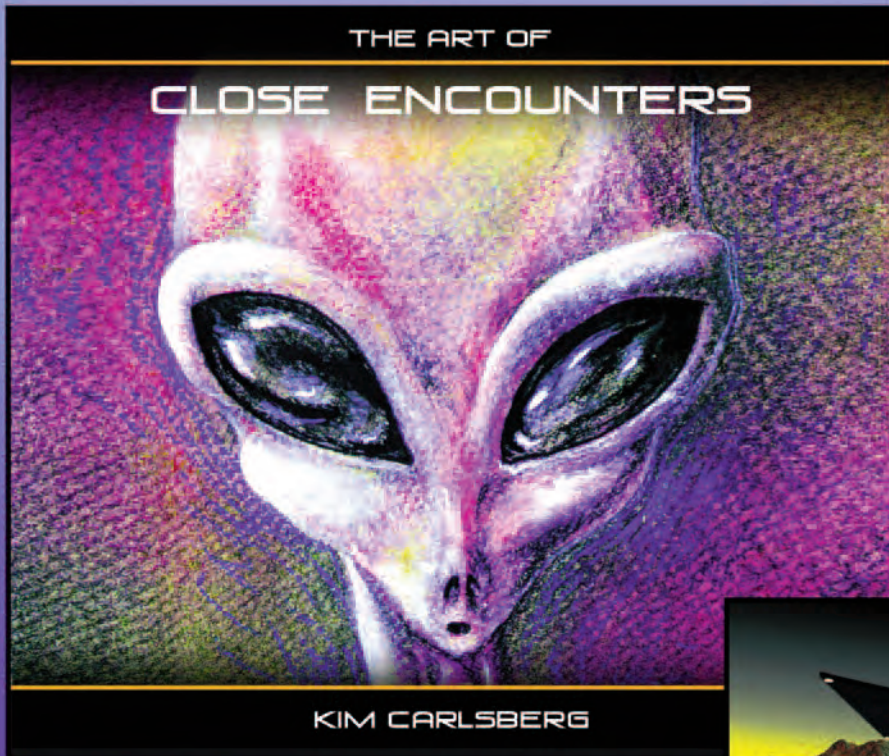

A remarkable achievement!
 - George Noory

Visually stunning, intellectually compelling, spiritually illuminating.
 - R. Leo Sprinkle, Ph.D

Every contactee should have this book.
 - Stephen Bassett



Full color, 350 pg, coffee table book, 150 illustrated stories. Breath-taking, mind-altering, heart-warming.

THE ART OF CLOSE ENCOUNTERS - HAS ARRIVED

After a 1988 close encounter in Malibu, California, Kim Carlsberg found herself in a shocking and inexplicable relationship with non-human entities. Carlsberg's journals became *Beyond My Wildest Dreams*, a book which still stands unique in the literature of alien abduction. The private response to her writings was intense in nature and vivid in detail.

Carlsberg's inspired invitation to participate in an encounter anthology gave others the opportunity to share their experiences. The result is a new milestone in the discourse of contact: *The Art of Close Encounters*.



The book is being printed. Order now online, or at the address below and be assured an autographed copy prior to Dec. 1st. Checks payable to: Close Encounters Publishing 567 W. Channel Islands Blvd. #696 Port Hueneme, CA 93041. Call 805.815.8989 for shipping info.

ORDER VIA WWW.NEXUSMAGAZINE.COM



ENERGY KINESIOLOGY BENEFITS AND LIMITATIONS

A technique developed from muscle testing may be the best modality in orthodox and alternative medicine for determining the optimum way to restore health because it utilises the body's own memory and wisdom, not guesswork.

by Steven Rochlitz, PhD ©
4 April 2011

Post Office Box 2154
Cottonwood, AZ 86326, USA

Email: info@wellatlast.com

Website:

<http://www.wellatlast.com>

Muscle testing and energy balancing can yield profound benefits for our health. Many imbalances in our bodies may best be found via this relatively new tool. Muscle testing may have spawned the best modality, in all of medicine, to determine the optimum way to restore health to us, because it is capable of tapping into the body's own memory and wisdom to try to correct health problems. This remarkable method, described below, can—under certain circumstances—be better than any external observer can be.

A Brief History of Modern Muscle Testing

Modern muscle testing, or applied kinesiology (AK), was discovered by George Goodheart, DC, in 1964. He incorporated his knowledge of several different fields, including kinesiology, and the discoveries of Drs Chapman and Bennett. Now, kinesiology—without the "applied"—refers to the centuries-old knowledge of gauging the strength of individual muscles, such as by getting the subject's arm or leg in certain positions while s/he resists the push or pull of an external tester. The only thing being tested for is the direct strength of that individual muscle. Dr Goodheart and later colleagues, however, found that individual muscles were energetically connected to specific acupuncture meridians, which in turn have been known for thousands of years to be energetically connected to individual organs. This is the so-called muscle/meridian/organ energy connection. But one has to be careful not to assume that the end organ is affected in a way that would show via standard western medical testing.

Dr Goodheart devised methods to strengthen individual muscles that had tested weak. He knew the discoveries of two physicians from the 1930s. Frank Chapman, DO, had found numerous points on the body that, when rubbed, increased lymph flow to certain areas or organs. Terrence Bennett, DC, had found that certain reflex points, when held, lightly increased blood flow to certain regions or organs in the body. Goodheart incorporated these two reflex systems into applied kinesiology, after seeing that they could strengthen individual weak muscles. Chapman's reflexes are now known as *neurolymphatic points*, and Bennett's reflexes are known as *neurovascular points*. These systems may also re-set the acupuncture meridians without needles. In addition, Goodheart found that certain techniques performed directly on weak muscles could immediately strengthen them. Some of these are called *spindle cell and Golgi tendon techniques*. They are among the quickest ways to correct muscles that are out of balance, yet they remain mostly unknown to massage and physical therapists. For example, a standard technique used by massage therapists is to massage a muscle so as to "reattach" its tendon end to bone. But Goodheart found that *simultaneously* working on the Golgi tendon areas of *both* ends of a set of muscle fibres can often do in seconds what working on just the one end cannot do in weeks or months of therapy. I think

that Dr Goodheart's discovery of applied kinesiology is greater than many that have been awarded the Nobel Prize in medicine, and thus he deserved one, too.

In 1973, Goodheart and colleagues started an organisation for licensed practitioners, called the International College of Applied Kinesiology (ICAK). Around the same time, John Thie, DC, wrote a book for the layperson called *Touch for Health*, and started teaching and certifying "everyone else" in this version of applied kinesiology. It entailed most of applied kinesiology, except for its use in testing and performing spinal vertebrae corrections. Indeed, the ICAK's definition of applied kinesiology included a phrase that it is to be done by chiropractors—somewhat like saying algebra is only to be used by someone with an advanced degree in mathematics. I mostly used the term Muscle Biofeedback Testing in my first book, *Allergies and Candida*. Nonetheless, the US Library of Congress, CIP division, mandated that I print that this book's topics include the term "Applied Kinesiology"—and that stopped a threat I once received over the use of those words. The Danish Chiropractic Association has declared that AK is a *non-chiropractic* technique, and chiropractors who use it risk licence forfeiture.

Surrogate Testing

Another simple breakthrough with this type of testing is the use of a surrogate. This way an infant, the unconscious and even pets can be tested. The energy flows from one individual to the next, and so the muscles of the surrogate can be used accurately to gauge the imbalances of an untestable subject, merely by holding hands. If the reader doubts this, I can relate that biofeedback devices are routinely demonstrated to show energy flowing between people, the final results via a meter or speaker proving that the first person's stress was passed "down the line".

I have tested people—via a surrogate—between the ages of a seven-month-old foetus and a 93-year-old lady. In conjunction with her mother, the foetus was tested for food sensitivities. The daughter-to-be was found to be sensitive to wheat and other foods. Wheat was avoided in her first few years of life outside the womb, as well as by the mother's first avoiding it while the daughter was still in the womb. The girl ended up being a genius, and this was evident in her first few years—reading and doing maths before the age of three. I had intelligent conversations with her when she was a year and a half

old. When her parents experimented with giving her wheat, it seemed that her intelligence and health faltered.

The Body Directs the Treatment

After Goodheart, perhaps the next greatest applied kinesiologist was Alan Beardall, DC. Some of his breakthroughs have led to what is called *advanced priority balancing*. He correlated all the muscles in the body with the acupuncture meridians. But perhaps more importantly, he created ways to communicate or "talk" to the body directly. Knowing *mudras* (finger or hand positions) that are part of yoga and *tai chi*, he incorporated many finger positions, or modes, to gauge various imbalances in the body immediately. He also, I believe, was the first to "talk to the body" or to "ask the body questions". This literally allows the tester to tap into the memory of the subject's brain and body to find out what is wrong, and then to ask the body to *direct* the optimum way to restore balance for any individual imbalance. It makes use of changes in muscle strength as a lie detector, just as standard lie detectors make use of changes in skin cells' electrical conductivity.

Our brains have recorded every single imbalance we have experienced, and know what is needed to counter each one, as we do in an advanced priority balance. While the imbalance is "locked in", the subject's body usually reveals to the tester a sequence of steps needed to correct the issue. These steps can involve body-work techniques, meridian energy balancing, correcting nutrient deficiencies, emotional balancing and other methods during the balance. In 1983, I incorporated this method into my system of (hopefully) testing for and balancing—as much as possible—the earliest causes of a person's problems.

I believe this may be the greatest health modality yet devised in both orthodox and alternative medicine! In itself it was also deserving, in my opinion, of a Nobel Prize in medicine for Dr Beardall, because all other health modalities involve the tester, practitioner or prescriber *guessing* what the person needs to get better. Here at last was a way to *get the only entity that really knows*—the "patient" him/herself—to give the answer, if only asked properly. This "low-tech" system can be greater than any "high-tech" system known to date. I recall at a health conference listening to a colleague in physics describing that "some day, we will be able to

...all other health modalities involve the tester, practitioner or prescriber *guessing* what the person needs to get better. Here at last was a way to *get the only entity that really knows...to give the answer...*

know what a person needs to get well by implanting a SQUID [superconducting quantum interference device] in their brain". When I tried to tell him about the "low-tech" system already being used by some of us, it led nowhere.

I note that just being hooked up *externally* to an electrical testing device can "switch" the person's energies, making the resultant testing inaccurate and causing illness to those who suffer from EMF sensitivity—which includes many who don't yet realise it.

The method of "asking the body questions" is used by some energy kinesiologists. This is not necessarily a good thing. The sad truth about any subtle energy testing is that it can easily be interfered with by the tester. This can be true not just of kinesiology but also of the pendulum and other modalities. (This is also the case for orthodox medical testing in other ways.) The muscle tester can subconsciously make the results come

out the way s/he wants them to. Alas, I believe that this occurs far more often than not. First, an egomaniacal guru type *always* gets the results s/he predicted ("curing" everybody); then his/her disciples find that their leader is *always* right with all *their* muscle testing. Some have claimed "instant, permanent allergy cures for everyone" with simple tapping or needling of body points. We will see below that this usually does not pan out.

Food Allergies and Nutritional Deficiencies

With muscle testing, food sensitivities can be ascertained without endangering the patient with intradermal injections or sublingual placement. The food can be placed on certain external body points while muscle testing. Being able to test foods and supplements this way is itself priceless. I have had readers and clients tell me that they became permanently environmentally ill just from intradermal food allergy testing. Others have actually, and needlessly, died just being tested for food allergies intradermally while being fasted at certain centres.

Nutritional deficiencies may also be ascertained with muscle testing. Around 1970, Robert Riddler, DC, found that he could test for deficiencies of vitamins, minerals and digestive enzymes by touching certain body points and muscle testing. These points are known as the *Riddler points*. My first discovery in kinesiology occurred in 1980 when I found that the so-called Riddler points were actually metabolic points whereby amino acids associated with vitamin or mineral co-factors could be gauged at the same test point. I used 24-hour urine amino acid assays to validate my findings. I was only

able to do this for a few amino acids. I understand that, sadly, the medical orthodoxy went after Dr Riddler and destroyed him.

Rapid Phobia and Emotional Balancing

Another field that has benefited from AK is psychology. The father of the field of "energy psychology" is considered to be Roger Callahan, PhD. His expertise was in phobias, and admittedly he did not see much improvement until he devised some AK methods. Perhaps his greatest advance is the finding that a "psychological reversal" may exist.

If so, it needs to be corrected before the phobia itself can be corrected. Via muscle testing, the problem can be ascertained without needing to have years of couch-lying and learning to "trust the doctor" before getting to the "deep stuff". One does not even have to say what the problem is: the subject can silently think of the

problem, and the tester can see if the result is a strong or weak muscle.

Dr Callahan saw that after correcting the psychological reversal with quick tapping of points, the phobia itself could be quickly fixed via tapping of *acupuncture meridian endpoints*. In other words, an over-energy is trapped in the meridians—not in the mind.

What I have found is that a phobia, emotional block or

imbalance can sometimes be "permanently" corrected, provided that the person is not suffering from any one of many medical problems (I cite over 30 medical conditions in my *Porphyrria* book) causing chronic imbalance in the body and subsequent susceptibility to great anxiety or phobias. If there are underlying medical problems (not just "allergies") and thus much anxiety or many phobias, energy psychology will not yield permanent cures but still may be useful in temporarily alleviating some distress.

Possible Abuse with Muscle Testing

The possible abuses that can occur in kinesiology should be pointed out to the reader. One example concerns a psychiatrist/kinesiologist. This practitioner, I was informed by one of my German publishers, as they also published his book, had been using muscle testing surreptitiously. He would silently and unknowingly (to the patient) ask their body, via muscle testing, what was the maximum they would or could pay for his session, and that maximum was what he would then charge. Though this was truly individual "treatment" via muscle testing, I don't think this is what the founders had in mind. I hear he was arrested and jailed in the UK.

Another important example concerns a psychiatrist/

One does not even have to say what the problem is: the subject can silently think of the problem, and the tester can see if the result is a strong or weak muscle.

author who uses muscle testing, but his practice of it is the very epitome of why some people avoid muscle testing at all costs. In his book, he describes how smoking tobacco can be good for you (or him) and how "it muscle tests good". Translation: this is the height of both the allergy/addiction syndrome and the delusion of making muscle testing come out the way one wants. Sure enough, I had the misfortune of meeting this individual at someone's party. There was a sign banning smoking, and despite my asking him not to smoke, as it was making me ill, he condescendingly ignored me. This highlights his disdain for other human beings and the law, and his delusion that this "natural" product is not harmful to anyone because he believes it is good for him (an addiction). And his muscle testing I trust is clearly something not likely to be the least bit accurate. I have said that sometimes the best kinesiologist is someone who uses the least kinesiology. It is well known that tobacco, and/or the smoking of it, releases many toxins. *It is not something that even needs to be tested on the non-delusional.* While it is possible that some young, super-healthy person might muscle test strong for an *unlit* cigarette, it's improbable that this would be the case for someone old and addicted to tobacco.

Likewise, there is potential danger in *self-testing*, whether via kinesiology, pendulum or any other method. If we are in an addictive state regarding a food and we know which foods we are testing for, our minds may make the self-test show "safe" when the food is not. So self-testing, if we do not have a regular partner, has the potential to be influenced to yield the results we want.

Another thing to be wary of is predicting the future. It is important to recognise that any testing is only valid for the time of the testing. Many variables can later interfere with and change things, so any parameter may test differently the next day or so.

Basic AK methods can be great for alleviating chronic fatigue and/or so-called brain fatigue. Often the body's energies are not flowing properly, and what the energy kinesiologist calls "neurological disorganisation" or "switching" occurs. Corrections can involve holding, tapping or rubbing certain points. As always, how long something lasts depends on what is causing the problem in the first place. Some testing and correcting of "switching" should occur first in a kinesiological session. That is because if energies are "running the wrong way", all the results can be inaccurate. Many times physicians, and others, use muscle testing without ever taking courses, and their results may all be inaccurate. (It is far more involved than it looks, if one cares to have accurate

testing.) Likewise, being hooked up to an electrical testing device (or using a phone) may switch the subject due to EMF reaction. And of course, whether a computerised "tester" or a human one is employed, *the answers can only be as good as the device or the tester's knowledge and questions.* If the real cause of the problem is unknown to either, one will not likely benefit greatly.

Rapid Corrections for Learning and Reading Problems

Specialised kinesiologists have made great inroads in testing and correcting, or improving, learning and reading disorders and possibly more serious brain disorders. Some of this involves *cross-crawl exercises*—the simultaneous use of the opposite arm and leg, like walking in place. Cross-crawl exercises go back to the 1950s and Glen Doman, Carl Delicato and others. They pioneered the use of the cross-crawl for brain-injured children and adults. Unfortunately, results either took a very long time to occur or little appreciable benefit was ever observed in some cases.

A major advance was provided by Paul Dennison, PhD, in the early 1980s. A fortuitous event occurred when someone was doing a type of cross-crawl exercise and happened to glance left at the phone which was ringing. An immediate cure of the person's dyslexia occurred. Also, by then, some people were doing the cross-

crawl with the hand crossing over and touching the opposite knee instead of going straight up in the air as Doman and Delicato did.

Dennison knew that looking left accessed the subject's right-brain hemisphere while doing the cross-crawl, and this helped yield the immediate positive result. This formed part of the basis for his Dennison Laterality Repatterning (DLR) Exercise. It included a second part of homolateral (same side arm and leg) crawling while looking right. However, others, including myself, would later show that part of this was an incorrect interpretation of things—despite how often disciples would test that it occurred. In more detail, Dr Dennison assumed that because the person showed a dyslexic tendency to start out with—muscle tested strong while looking at parallel lines (homolaterality), and tested weak while looking at an "X" (cross-laterality)—the two results should be reversed after the correction. I have shown that not only is this wrong, *it is impossible.*

You cannot "extinguish the homolateral" aspect, as that still occurs in the body. There are cross-lateral and homolateral energy flows in the body all the time. And homolaterality *per se* is not bad. The eyes are connected to both the same-side brain hemisphere *and* the opposite-side brain hemisphere. You cannot "extinguish

Likewise, being hooked up to an electrical testing device (or using a phone) may switch the subject due to EMF reaction.

the homolateral" by doing a homolateral crawl and looking right. I gave the example that the basic wiring in a circuit is like doing the homolateral. If no battery is hooked up, there is no current flow. This is like testing strong to looking at the "II" but weak to the "X". When the "X" is made strong, the current flows. We do not vaporise the electrical wiring. Indeed, there is no circuit with just a battery and no wiring. One ends up being strong for *both* homolateral and cross-lateral flows. And it is very instructive to learn that thousands or millions of times, disciples have tested people after doing the Dennison repatterning and they tested *weak* to looking at the "II". I am saying that *this is impossible* because the higher step intrinsically needs and incorporates the lower step here—like a current flowing *only* if the battery and the wiring are intact. Yet so many times the tester makes the result come up the way they were told it should.

A simple experiment is to tell someone to correct a dyslexic with the so-called DLR Exercise without telling him or her how the results should muscle test. Fortunately, though, for dyslexic children or adults, the DLR correction still works, even though half of it is unnecessary and misinterpreted. In 1985, I devised my own Brain Integration Exercises and beyond. Mine include humming while doing the improved cross-crawl.

Carl Ferreri, DC, an applied kinesiologist, also pioneered rapid dyslexia corrections but with cranial adjustments, especially on the right sphenoid bone. This can be painful. In 1985, I had a chiropractor, trained by him, do this on me. We were both at a seminar. Though far from dyslexic *per se*, I tested weak on my right sphenoid bone and he adjusted it. He then added that it was "permanent". I said, "Really? Let me get something." I went to the hotel's lobby, bought a chocolate candy bar and ate a bite. (Maybe this was just an excuse to satisfy my own desire?) I asked him to re-test the "permanent" right sphenoid bone correction. It was out again. Nonetheless, this adjustment can be an effective, if painful, adjunct.

Correcting "Dyslexic Heart" and Meridians

By 1985, I had become both the first to explain how the Brain Integration Exercises really work, and the first to devise the field of Heart Integration Exercises to correct what I call *dyslexic heart*. Some, such as Dennison, claimed that the newer-type brain repatterning exercise

with the hand touching the opposite knee worked better than the older cross-crawl with the arm going straight up in the air, because "the arm crossed the midline". Others speculated that the arm crossing over utilised the spine more, and thus cerebrospinal fluid might be better pumped into the brain.

I believe that by 1985 I had proved that both these assumptions were incorrect and that my explanation was more elegant and more accurate. The arm crossing over and touching the opposite knee utilises the supraspinatus muscle, which is the AK muscle that is energetically connected to the brain! I showed that this is a subset of the Rochlitz Meridian Integration Exercises, whereby each of the body's 14 meridians can be rebalanced via the use of a cross-crawl exercise that utilises the corresponding muscle while humming or counting.

A few years after I created the field of the Rochlitz Heart Integration Exercises, I wrote and published my book *Why Do Music Conductors Live Into Their 90s?: The Simple Revolutionary Discovery That Can Make You Live Longer, Increase Your Stamina & Stretch, and Normalize Your Blood Pressure In Minutes*, about what these integration exercises could do. Humming while moving both arms as conductors do—while also doing circular eye tracking—is the simplest of the three Rochlitz Heart Integration Exercises. Doing this daily may help you live to your 90s like many music conductors have.

By 1987, I had gone beyond all this and created the Rochlitz Meta-Integration Exercises, which have *all four limbs in motion*. Its three distinct levels are a large step beyond all the two-limbed cross-crawls for the brain, heart and all the other organs/meridians. It was a shock

to the cross-crawl community in that I was the first to realise we have four limbs that should all be able to be used simultaneously. It seems that this is still not comprehended or appreciated in that community.

Rapid Correction for Multiple Sclerosis

What the Rochlitz Heart Integration Exercises can do was witnessed in Neumarkt, Germany, in 1992. Dr Med. Petra Jung wrote (*Townsend Letter for Doctors*, Feb/Mar 1995): "...I attended a five-day workshop taught by Professor Steven Rochlitz. Of the 70 people in attendance, about 30 were medical physicians as I am... After Rochlitz had demonstrated his Heart Integration Exercise...a middle-aged man [was brought in] with

Humming while moving both arms as conductors do—while also doing circular eye tracking—is the simplest of the three Rochlitz Heart Integration Exercises. Doing this daily may help you live to your 90s...

Multiple Sclerosis... He had been diagnosed [four years earlier] and treated by orthodox physicians with a continual worsening of this condition. His left leg showed signs of paralysis. He had a noticeably poor gait—he limped. He complained about burning feet and loss of sensation in both his left leg and arm/hand. His left handshake was considerably weaker than his right. He clearly had problems walking straight ahead. He obviously couldn't run and he was only able to walk (limp) quite slowly... Rochlitz then had the patient perform his Heart Integration Exercise—with the aid of four students [helping to move his limbs due to his MS difficulties.] This only took a few minutes. He was asked to walk again. His limp was now barely perceptible. In fact, he now could easily run, and in fact it was a fast run that was itself almost without fault. He then manifested handshakes of equal strength—his left now had the same strength as his right. He reported normal sensation in both his left leg and arm.

Further improvements were made with other kinesiological corrections... After all this—which took less than half an hour—he would not be identifiable by gait, strength, loss of sensation, etc. as someone suffering from MS."

After he ran almost normally, the entire class gave me a standing ovation. And that was with utilising only basic methods, not the advanced methodology.

Later, when the above account and other material were published in the *Townsend Letter for Doctors*, Dr Goodheart wrote to me and congratulated me.

Instant, Permanent Allergy Cures? Or Not...

I relate now what I have found about the "instant, permanent allergy-curing field". In 1997, a well-known clinical ecologist (environmental illness physician) flew me out to work on his 10 worst "cases". He had earlier flown to see me for his own problems. I recall his asking me, "Why do I fall asleep after eating rice, if I was muscle tested as being cured for my rice allergy?" (He was not cured, as my testing soon revealed.) His patients were tested before and after using one of the "cure all your allergies instantly and permanently" systems. Despite his assistant re-testing that all their allergies were "permanently cured", these people were still very sick. Simple testing when I got there revealed that little if any "allergy curing" had taken place. They still tested weak to nearly all these "cured" foods. The earlier re-testing was nearly totally inaccurate.

Now, we mostly react to foods and chemicals for many underlying reasons, which my previous articles in *Nexus* have addressed. There are often serious underlying genetic or congenital medical problems occurring, and they may not be so easily cured. Some of the sickest people I have seen were those who were *daily* ingesting foods which were "re-tested as cured", despite having old or new symptoms after eating those foods. The delusions sometimes included eating toxic foods containing caffeine or alcohol. I am not saying that the energy balancing in these systems is of no value. Any energy balancing—AK, acupuncture, acupressure, reflexology, homeopathy, etc.—is usually beneficial. But everything

has its limitations as well as its benefits. Note that regarding the above gentleman with MS, I did not expect what I did for him to be "permanent", in part because he drank coffee, smoked and had mercury amalgam in his mouth.

When I test people, if I get results that are the opposite of what I might be expecting at least some of the time, I *rejoice in being proven wrong*. This way I am somewhat reassured that I am not making the testing come out the way I might subconsciously want.

I also have to watch out for my own imbalances or switching possibly affecting the testing.

Both the tester and the subject should first do corrections for switching before commencing any serious muscle testing. Unfortunately, some people just start doing muscle testing without ever taking courses to try to make it accurate.

Their touch may also be either too strong or too weak, making it

**“You got very sick after taking the remedies? That’s great! That’s the die-off effect!”
In reality, the sufferer may just be having an allergic or porphyric reaction to the herbs, and *he or she* may be the only one “dying off”.**

all inaccurate.

Many kinesiological "systems" have resulted in the last several decades. Sometimes people have significant new discoveries to show, but often muscle testing is just used to "verify" that someone's philosophy is the greatest truth in the universe. Also, many energy kinesiologists do not appreciably help those with chronic or environmental illnesses, despite—or because of—extensive training in systems or schools that emphasise balancing people's emotions or "colours".

Because kinesiological testing for allergies or sensitivities to foods, and especially supplements, is known to be often inaccurate, I devoted much time and effort in the last 31 years to this matter. First, I devised special methods to make the testing more accurate for supplements, as these when placed on the body tend to "fill an energy hole" and make the arm appear strong and

thus can fool the body. More recently, I created methods to get accurate results for foods and supplements that are causing porphyric—*not* allergic—sensitivities; likewise with pyroluria reactions. These will not show up any other way.

Parasite Die-off or Patient Die-off?

Back in 1983, I had first become known for creating The *Candida* Balance. Now, for overgrowths of *any* "critters", it is crucial to have accurate testing. Too many severely ill people get very sick when they are given herbs or drugs to kill their parasitic overgrowths. All too often the practitioner says, "You got very sick after taking the remedies? That's great! That's the die-off effect!" In reality, the sufferer may just be having an allergic or porphyric reaction to the herbs, and *he or she may be the only one "dying off"*. Truly accurate muscle testing, though rare, can help ascertain remedies that will be *safe and effective* even *before* taking them. This is the supposed holy grail of health.

The medical orthodoxy has not been happy with the creation and use of AK. Brian Briggs, MD, has related how when he first found out about AK and began to use it, he wrote to medical authorities and insurance companies. He told them that serious drug reactions could now be prevented by first muscle testing the drugs on patients. His medical licence was promptly suspended by his state board.

It's a sad fact that many chiropractic colleges and state boards try to disallow the use and teaching of AK. Instead, AK should be taught as part of the curriculum in all medical, dental, chiropractic, osteopathic, naturopathic, veterinarian, massage, physical therapy and other schools or training.

A Balanced Approach

Importantly, muscle testing belongs in every family. Our allergies, nutritional deficiencies, physical and emotional pains, overgrowths and countless other things change from day to day. A friend, relative or partner is crucial, especially for those chronically sick or allergic. Muscle testing can yield accurate results if the right things are done. Yes, the opposite occurs all too frequently, but now you know what may be involved. And common sense, as in the matter of smoking, still has its place.

So we have seen that muscle testing, or applied kinesiology, can be used to test for meridian energy imbalance and for energy imbalance associated with allergies, nutritional deficiencies, phobias, overgrowths of micro-organisms, physical or emotional pains, spinal

or cranial faults and many other things. This type of testing *can* be quick, relatively inexpensive and accurate. Advanced testing and balancing allows for accessing the subject's brain to possibly find out the deepest cause of a problem, and then for the subject's body to tell the tester (instead of vice-versa)—if only asked in a special and accurate manner—the optimum way of fixing the problem. This can be among the greatest modalities in all of medicine. It can also be greatly abused, or rendered totally subjective and worthless. It should not be a substitute for standard medical testing, if such testing is affordable, accurate and not corrupted. This is not always the case, as with porphyria testing.

Like everything else with our species, muscle testing

and energy balancing can be used to our great advantage, or can be misused. It's up to us to learn more, do the right things and act wisely. Wisdom dictates that in an age of Chernobyls, chemtrails, candy bars and countless other stresses, the very concept of "permanent" energy balancing may be absurd. Indeed, *these ubiquitous toxins highlight the need for each of us to learn how to balance and re-balance ourselves continually, and not to*

expect magic—pills or energy balancing!

Learning kinesiological testing and balancing may be even more imperative now, as the governments of many countries remove natural remedies from their citizens. All that energy kinesiology testing and balancing require are our own hands and brains. Kinesiological testing and energy balancing—when used wisely—can be a wonderful health tool that every human being should consider learning...*now*. ∞

About the Author:

Steven Rochlitz, PhD, was originally a physics professor. For the past 31 years, he has researched chronic and environmental illnesses and taught his seminars across the world. His unique system incorporates breakthroughs in energy kinesiology, nutrition and human ecology. He is the creator of Heart, Meridian and Meta-Integration Exercises, as well as being the first to explain how Brain Integration Exercises work. His books and seminars cover basic and advanced kinesiology, including his own discoveries. His latest of nine books, *Porphyria: The Ultimate Cause of Chronic and Environmental Illnesses*, has been cited as a significant health breakthrough. His articles "Hiatal Hernia Syndrome with Vagus Nerve Imbalance", "The Hole in the Heart and the Blood-Brain Barrier" and "Porphyria: A Cause of Chronic Illnesses" were published in NEXUS 18/04, 18/03 and 18/01 respectively. Further research is at his website <http://www.wellatlast.com>. Dr Rochlitz can be emailed at info@wellatlast.com.

“After all this—which took less than half an hour—he would not be identifiable by gait, strength, loss of sensation, etc. as someone suffering from MS.”

ONLINE SUBSCRIPTIONS

- \$20 per year
(+\$2 GST for Australia)
- six issues/year
- content same as hard copy,
only ads may differ
- personal email notification
when issue ready to download

To subscribe, visit
www.nexusmagazine.com

A COSMOLOGICAL JOURNEY OF GALACTIC PROPORTIONS

This new model of the universe posits that consciousness generates life, that black holes exist at the subatomic level as well as in deep space, and that light is infinite but curled up in higher dimensions. It blows away the Big Bang theory.

by Manjir Samanta-Laughton, MBBS © 2011

Paradigm Revolution Publishing
Post Office Box 113
Buxton, SK17 9WP
United Kingdom

Website:
www.paradigmrevolution.com

How Modern Science is Taking Us Back to Ancient Wisdom

It was early 2004 and I looked up from the report in *New Scientist* magazine. Antimatter had been found pouring from the heart of our very own Milky Way galaxy, and astrophysicists did not know why.¹ But strange though this was, it was totally predictable from the theories I had published in a paper the previous year.² How was it that I knew something that the astrophysicists themselves did not? And why me? Why was a female, British Asian, medical GP without even an A-level in physics and barely out of her twenties coming up with all these ideas about the cosmos? It was that moment that prompted me to overcome my reservations about writing the book that eventually became *Punk Science*.³

Believe me, this is not where I thought I would end up: putting forward a new theory in physics. I am from a medical family and trained as a GP, like my parents. But after a spontaneous spiritual awakening, which happened in my first few weeks of medical school, I added a burgeoning mystical life to my medical studies. Pretty soon, I realised that the principles of the universe that I was experiencing mystically must have their correlation within the scientific realms.

To start with, I simply wanted to explain these esoteric principles in terms of modern physics. Like authors who had published before me, I could see the links between esoteric principles such as distant healing and non-locality in quantum theory. So I started learning about ideas in cutting-edge physics and comparing these with traditional esoteric principles. My aim in the beginning was to provide better care for my patients. I had a (perhaps naive) belief that if doctors simply understood the physics behind energy healing modalities, then maybe they would lose their fear of including them in medical practice and consequently patients would benefit from these powerful, non-toxic treatments. But this journey took me somewhere quite different.

At the Heart of Every Galaxy

It was the autumn of 2003 and I had become captivated by the field of cosmology which had been in turmoil since around the turn of the century, with many long-held beliefs becoming obsolete as data came pouring in from telescopes. Cosmologists had just faced one of their biggest challenges for years: the unwelcome arrival of dark energy, a mysterious force that seemed to be blowing the universe apart and accelerating its expansion.

Images from Hubble and other telescopes were throwing open some of our long-cherished beliefs and making us question our theories and expectations about the universe. I became particularly fascinated by black holes. The concept started life as a conclusion of Einstein's theory of relativity: that if space and time curved beyond a certain point, they would create a point of infinite gravity. Initially it was thought that certain stars collapse at the end of their lives and produce these points of infinite density and gravity, with a pull

so powerful that not even light can escape—hence a “black” hole. For decades, these objects remained a theoretical concept: they sparked the imaginations of science fiction writers, but it was not known if black holes really existed. It was not until the dawning of the 21st century when our telescopes were picking up black holes everywhere that we realised that not only did black holes exist, but they were actually quite common.⁴ How is a black hole detected if no light can escape it? One of the ways is to look at the material around them: an accretion disc which spins very fast around it—so fast that only the gravity of a black hole could be creating it.

Amazingly, when we turned our telescopes on nearby galaxies, we found a supermassive black hole at the heart of each one. We even found a black hole at the centre of our own galaxy! So instead of being rare exotic creatures, black holes are actually quite common, appearing not only in the heart of every galaxy but with smaller black holes all over our galaxy, too. Sometimes they are associated with objects such as quasars which give out bright radiation. But hold on a minute: why would a quasar, which has an associated black hole, give out such bright radiation? Surely the black hole would suck up all the light so that we couldn't see it? Indeed! In fact, the more we looked, the more the data showed up surprises that contradicted our current theories.

The Great Annihilators

It was in studying objects called microquasars, which are smaller version of quasars, that I started to find some answers. Microquasars also have a black hole associated with them, but their behaviour again is peculiar. They, too, are spewing out material very rapidly despite the black hole associated with them. Sometimes they give out gamma ray radiation, sometimes electrons at close to the speed of light, and sometimes the antimatter

opposite of electrons: positrons. Because we know that within microquasars, antimatter and matter combine to form light in the form of gamma rays, a process called “annihilation”, *New Scientist* magazine dubbed them “The Great Annihilators”.⁵

What is the cause of this strange behaviour? Why are microquasars spewing out material so rapidly? If there is a black hole associated with a microquasar, then why isn't it sucking up everything? Astronomer Sir Martin Rees commented that we should study microquasars because what we find out about black holes of this size will inform us about larger black holes; so there is a general agreement that all black holes probably behave in the same way, just at different scales.⁶

The Universe Speaks

I was pondering all of these conundrums—black holes, dark matter, dark energy and microquasars—as I took a walk with my dog in the woods in the autumn of 2003. I also wanted to find out how everything fitted together with the notion that consciousness is fundamental to the universe, which has arisen out of the work of quantum physicists such as Amit Goswami⁷ and Fred Alan Wolf.⁸ Radical scientists such as these had looked at the conclusions of quantum physics which tell us that a subatomic particle only comes into existence when it is measured. They realised that the act of conscious observation has a role in creating reality. Some physicists have gone further and concluded that consciousness is fundamental to the universe.

Mulling all of this over in the woods, I took a rest on an oak tree branch and remembered something I had seen years ago in a video featuring the mathematical cosmologist Brian Swimme.⁹ He recommended that we take time to tune in to the rotation of our own planet; and, for some reason, here on this branch of an oak tree

was the first time I tried it. What came next is something I find hard to describe, but it was as if I had been thrown into the very fabric of the universe and caught a glimpse of its secrets. Everything seemed to be made up of the most exquisite geometry and mathematics, which were at the same time both infinitely complex and ever so simple. I suddenly understood how black holes work, and it wasn't at all how we had previously theorised. I had been shown what I now call the Black Hole Principle, and it was a discovery that would profoundly alter the course of my life.

Dimensions of Consciousness

In order to understand the Black Hole Principle, we first need to

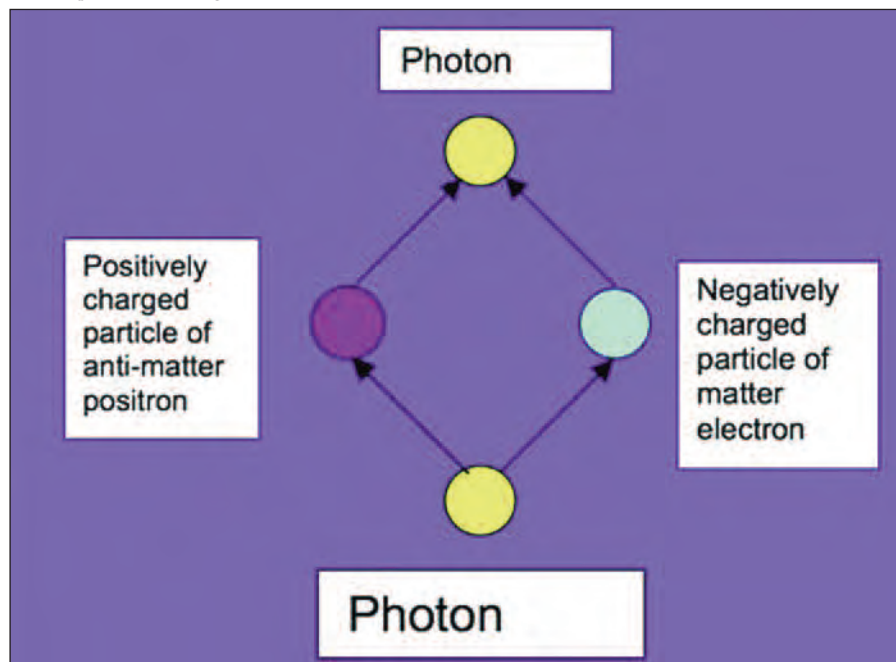

discuss a few other scientific ideas. One is that the universe is made up of many dimensions. This concept started in physics after Einstein had successfully united space and time. What Einstein did was the equivalent of going up a hill to look at the big picture in a disorganised crowd: the scene becomes unified, and you can see what's going on from a higher perspective instead of seeing chaos on the ground. This is effectively what Einstein did in mathematical terms.

Ever since, people have been finding a way to unite all the forces of nature, and sometimes they have been creating higher dimensions to do it, as found in string theory. These higher dimensions are all around us, but we can't see them because they have different geometric qualities. Physicists used to think that these dimensions are very small, but they changed their minds and started realising that these dimensions could be worlds of their own.¹⁰ So, according to physics, we live in a universe of many dimensions.

The Infinite Light of Heretics

Another concept that has come out of academic physics in recent years is that the speed of light is not the speed limit of the universe. It sounds crazy, but some radical thinkers such as Professor João Magueijo in London have been postulating that the way to solve some of the problems we have in cosmology, such as the horizon problem and the flatness problem, is to realise that the speed of light is variable and was faster in the early universe.¹¹ Magueijo even goes on to say that light is infinite and is curled up in higher dimensions.^{12, 13}

So what we see as the speed of light is actually a small fraction of its actual speed, which is infinite.

Naturally, these ideas have caused a storm in the world of physics, with some people branding Magueijo and colleagues as heretics.

But it leaves us with the notions that the universe is one of infinite light that contains many dimensions; and if we put that together with ideas coming from quantum theory, it is also alive with consciousness. All this has come from physicists themselves in the academic world—not from New Age postulations—which makes these ideas so remarkable.

Beyond the Perception Horizon

When I started to piece all this together, I realised that what we call dark matter or dark energy is not actually dark at all: it is "superbright!"¹⁴ What we have been

calling the speed limit of the universe is not the speed limit at all: it is simply a reflection of the limitations of consciousness in what we call our reality—three spatial dimensions and one of time. The speed of light then becomes the Perception Horizon, beyond which we don't perceive anything with our normal senses and our instruments which are attuned to this dimension alone. However, the areas of the universe which lie beyond this Perception Horizon are the realms that mystics have been discussing throughout the ages, e.g., the light perceived in deep, meditative states.

So what does this have to do with black holes? Well, in that insightful instant, which only lasted a few seconds but imparted volumes worth of books to me, I realised

that black holes are not dark, guzzling monsters at all. We have got it all wrong. They are actually the source of infinite light. This infinite light lies at the heart of black holes. It spirals from the centre, down through the dimensions to the edge of our perception where the light then splits off into a particle of matter, such as an electron, and a particle of antimatter, a positron. This is why we see electrons spewing out of black holes at the speed of light, because they have only just reached our dimension and therefore our perception.

And that is not all. This is a breathing process and it works both ways. Positrons and electrons recombine to form gamma rays. Black holes are therefore the source of the gamma ray bursts that we have seen coming from even the furthest regions of our cosmos and have puzzled scientists for over 50 years since they were discovered. We even have evidence of this breathing process happening near

our own Milky Way galaxy: high-energy gases close to the centre of our galaxy have been noticed to be moving in and out, and nobody seems to know why, but this finding totally fits our theory.¹⁶

Burping Black Holes

We may also be able to account for the strange patterns we see coming from black holes. Many astrophysicists think that the emissions from black holes are the result of explosions or black holes guzzling up matter such as stars, causing matter to be ejected in the process. But instead of a steady decay of emissions as expected after an explosion, the pattern of emissions is more erratic, leading to bizarre concepts such as the one that black holes burp on their food!¹⁷

What we have been calling the speed limit of the universe is not the speed limit at all: it is simply a reflection of the limitations of consciousness in what we call our reality—three spatial dimensions and one of time.

The Perception Horizon

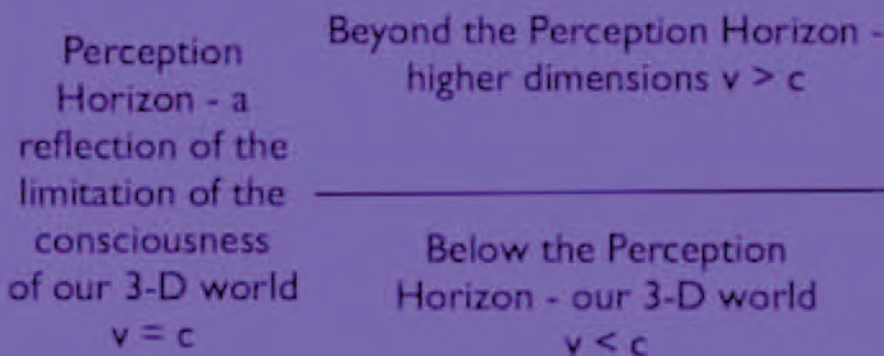

an atom, can now be seen in a new perspective. Even planets and stars show the same pattern of periodic ejections and emissions of high-energy electrons and light. Just look at the X-ray and gamma ray radiation found around the planets of our solar system, the mysterious plumes given off by Jupiter, and solar flares, which remarkably display the same cycling of antimatter and matter that we see in supermassive black holes.^{19, 20}

Our own planet Earth is the site of some astonishing evidence of the Black Hole Principle. Now surely, our own planet cannot be full of fractal black holes? But if you remember, the term "black holes" is now a misnomer

Once we understand that a deeper process is occurring in black holes than an explosion process that is limited to our dimension, then we won't need to create these bizarre explanations as we now have a simple, elegant theory that can make some powerful predictions.

I also realised that the Black Hole Principle does not just end with black holes in the cosmos: this same signature behaviour is present at every level in a fractal fashion, from objects as small as atoms and quarks to supermassive black holes and even structures in between, such as stars and planets. If I am right, we would see the following types of behaviours in structures:

- emissions of electrons at almost light speed;
- annihilation processes present in antimatter and matter;
- emissions of antimatter;
- emissions of gamma ray radiation;
- patterns that are unpredictable, with hours or maybe days between flares;
- a bipolar jet-like concentrated pattern of emissions.

as these are actually the source of infinite light and are the creative forces in the cosmos. It is something that cosmologists themselves were forced to announce in 2010, mainly due to the fact that the size of every galaxy has such a direct correlation to the size of the supermassive black hole at its centre that it was no longer possible to deny the creative role of black holes.²¹

Bolt Upright

So let's look back at some of the criteria for black hole behaviour and compare these to our own planet. Where do we see high-energy electrons moving at very fast speeds on our own planet? In lightning! We are often given the impression that lightning is created by a sort of static electricity which builds up in the clouds, yet nobody has been able to prove this. The measurements that have been taken actually show that the power build-

The Fractal World

After publishing my initial ideas in a journal in the winter of 2003, I spent the next two years researching and verifying this theory which I called the Black Hole Principle. Sure enough, a lot of the unexplained behaviours of various objects in the cosmos from red dwarfs to planets fit this pattern. Even comets were throwing up surprises for astrophysicists, but not for me: their behaviour fits the Black Hole Principle perfectly.¹⁸ Behaviour that we have known about for a long time, like radioactivity and the quantum jumps of an electron within

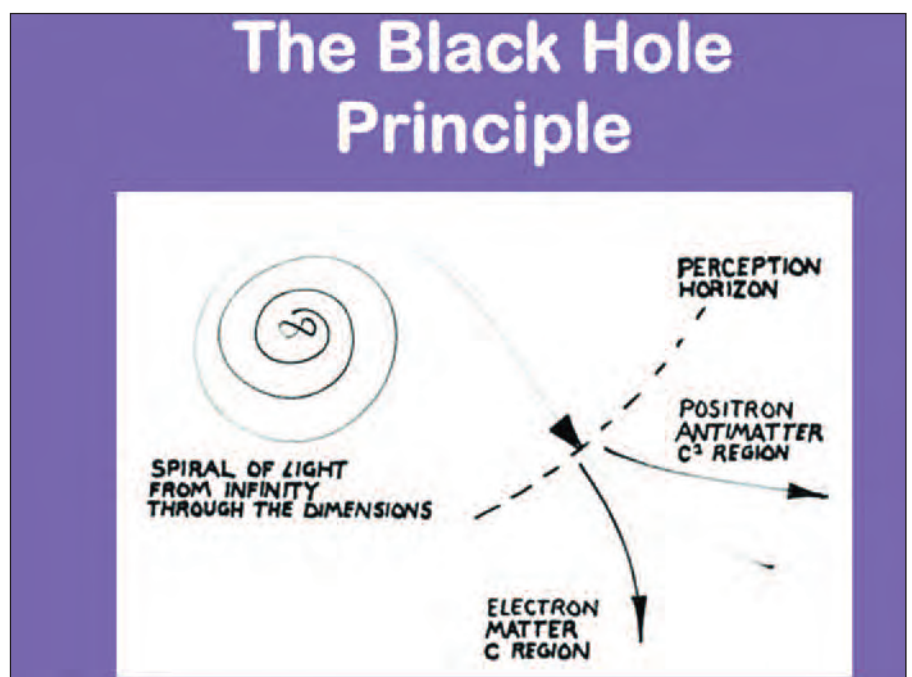

up is not nearly enough to cause a bolt of lightning.²²

When a lightning bolt hits the Earth, it is travelling at the speed of light. Amazingly, recent discoveries have shown that gamma ray flashes that exist in the Earth's upper atmosphere are associated with thunderstorms and lightning bolts, and just this year alone NASA has found that antimatter is being emitted, too.^{23, 24} So now we have periodic ejections of electrons, gamma rays and antimatter as well as the presence of matter-antimatter annihilation, just as we find in a supermassive black hole at the centre of a galaxy.²⁵ But it is happening not just in outer space, but in our own atmosphere! It is the same Black Hole Principle happening at every single level. There are many more examples given in my book *Punk Science*, including DNA, quarks and the long-derided concept of chakras.²⁶

We live in a fractal black hole universe with the signature of creation happening at every single level in everything. Every level of the universe is being created in every moment via spirals of light from infinity. When they reach our dimension, delineated at what we are currently calling the speed of light but which is really the limitation of our perceptions in our dimension, they split into the antimatter and the matter which make up our universe and a mirror universe to ours. The matter universe is the one which we are mostly aware of in our daily lives.

Bang Goes the Theory

This means that creation is happening at every single level, and did not happen at just one single point 15 billion years ago. There was no Big Bang. Astonishingly, the very evidence that was supposed to support the Big Bang theory is showing up its deficiencies. This has prompted a group of cosmologists to form the Alternative Cosmology Group, protesting that unless you work on the Big Bang theory you will not get academic funding.²⁷

However, the more we look at the evidence, the more the Big Bang theory disintegrates. For example, when we started looking deeper into the universe, we expected to find only younger stars. As it has taken a longer time for the light to reach us, we should be looking into the early

universe. But that is not the case. No matter where we look, the universe looks the same: old stars and young stars appear everywhere.²⁸

The other piece of evidence that was supposed to cement the Big Bang theory, but instead derailed it, is the measurement of the cosmic microwave background radiation. Discovered by accident in the 1960s by Penzias and Wilson, this radiation has been interpreted as the remnants of the Big Bang. We even faintly pick it up as the "snowstorm" picture on our television sets. But strange features started to appear in the microwave background. Curious alignments and axes were seen that

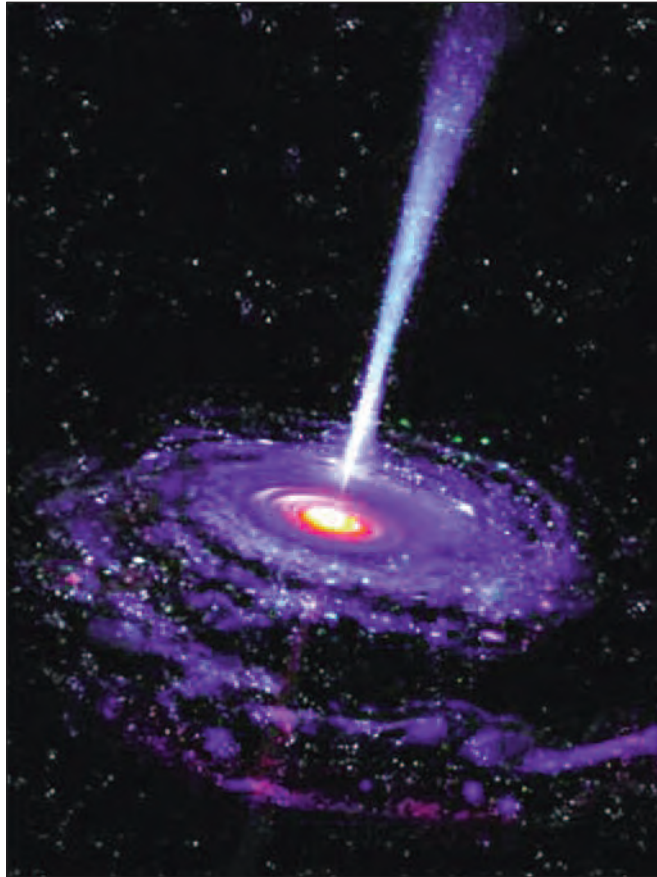

relate to current structures.^{29, 30} This means that instead of being related to an event that happened billions of years ago, the microwave background shows alignments to current objects. With microwaves being emitted by our very own Milky Way black hole, it could be that the microwave background radiation is aligned because it is being emitted by them in the here and now!³¹

Time and time again, findings that were puzzling to astrophysicists were perfectly fitting the Black Hole Principle. The predictions I have outlined above apply to structures as small as a quark and as unexpected as a brown dwarf star.^{32, 33}

So when I found that antimatter is pouring out of our own Milky Way galaxy in a veritable fountain—to the surprise of many, but totally predictable by this theory—I realised that too much evidence was accumulating for me to keep this theory to myself: it needed to get out there.³⁴ So I collated the data and published it in my book *Punk Science*, which provides many of the references for further reading. Since then, of course, we have discovered massive bipolar gamma ray emissions coming from our own galaxy, too—another iteration of the theory.³⁵

Nothing New Under the Black Hole Sun

It has been a difficult journey at times, requiring me to leave behind the familiar life of a medical doctor and step into uncharted territory. The discovery of similar theories from groups around the world just reiterates that we are in the middle of a massive scientific revolution. In fact,

many scientists even a hundred years ago were formulating similar theories, but did not have the astrophysics data that we have acquired in the last few decades to express them in this way.

Going even further back, we realise that the concept that galactic centres are a creative force in the universe has been described by many earlier cultures. The Maya regarded the centre of the galaxy as the Great Mother or Cosmic Womb. The Gnostics had a creation myth, possibly inherited from earlier cultures, that describes the fall of a goddess from the centre of a galaxy, swirling around and falling through some sort of cosmic boundary before creating our world. Maybe this knowledge has something to do with the spirals depicted in ancient art, such as at Newgrange in Ireland.

I get a sense that the time for this theory has come, and that we are simply rediscovering what we used to know. Maybe we had to move away from this ancient knowledge of the cycles of time so that we could rediscover it now, with the benefit of our current technologies which bring us right back to what our ancestors knew: that everything is a spiral of living, breathing, creative light from infinity

occurring at every level, and that at the heart of every spiral is the same infinite oneness that connects every structure in the universe from the very large to the very small. ∞

About the Author:

Manjir Samanta-Laughton, MBBS, Dip. Bio-Energy, is an award-winning author and international speaker. She is a former medical GP, a bio-energy therapist and an holistic doctor at the Bristol Cancer Help Centre, UK. She has also become a leading light in the field of linking cutting-edge science and spirituality. In recognition of her work, she was asked to join a prestigious group of scientists and philosophers for a 2008 meeting in Japan which

...at the heart of every spiral is the same infinite oneness that connects every structure in the universe from the very large to the very small.

examined the underlying assumptions behind science; the meeting led to the creation of the influential Science Evolve group. Her two published books, *Punk Science* (O-Books, 2006) and *The Genius Groove* (Paradigm Revolution Publishing, 2009), have been translated into several languages.

Dr Samanta-Laughton can be contacted via her website <http://www.paradigmrevolution.com>.

Endnotes

1. Reich E.S., "When Antimatter Attacks...", *New Scientist*, 24 April 2004, pp. 34-37
2. Samanta-Laughton M., "Quantum Bio-cosmology: The Science of Auras and Chakras", *Holistic Health*, vol. 79, Winter 2003-04, pp. 16-21
3. Samanta-Laughton M., *Punk Science*, O-Books, Alresford, Hants., UK, 2006
4. Minkel J.R., "Bye Bye Black Hole", *New Scientist*, 22 January 2005, pp. 29-33
5. Henbest N., "The Great Annihilators", *New Scientist*, 1 April 2000, pp. 28-31
6. *ibid.*
7. Goswami A., *The Self-Aware Universe*, Jeremy P. Tarcher/ Putnam, New York, 1993
8. Wolf F.A., *Star Wave*, Macmillan, New York, 1984
9. Swimme B., *Canticle to the Cosmos* (DVD series)
10. Lykken J., *The Physics of Extra Dimensions*, QuickTime video associated with Enrico Fermi Institute lecture, 15 February 2003
11. Magueijo J., *Faster than the Speed of Light*, Arrow Books, London, 2004
12. Williams R., "Speed of Light", *The Science Show*, ABC Radio National, 18 November 2000, <http://tinyurl.com/42zdema>
13. Magueijo J., *op. cit.*
14. Milewski J.V., "Superlight: One Source, One Force", 17 November 1996, <http://tinyurl.com/3b8zg4n>
16. Wakker B.P. and P. Richter, "Our Growing, Breathing Galaxy", *Scientific American*, January 2004, pp. 28-37
17. Schilling G., "Do Black Holes Play with Their Food?", *ScienceNOW*, 18 August 2005, p. 4
18. Clark S., "Comet Tails of the Unexpected", *New Scientist*, 10 September 2005, pp. 32-35
19. Bryner J., "Giant Storms Erupt on Jupiter", *Space.com*, 25 January 2008, <http://tinyurl.com/42n5953>
20. Muir H., "Celestial Fire", *New Scientist*, 21 June 2003, pp. 1-4
21. Chown M., "Supermassive Black Holes – The Fathers of Galaxies", *New Scientist*, 6 January 2010, pp. 30-33
22. Gosline A., "Thunderbolts from Space", *New Scientist*, 7 May 2005, pp. 30-34
23. *ibid.*
24. NASA, "NASA's Fermi Catches Thunderstorms Hurling Antimatter into Space", 10 January 2011, <http://tinyurl.com/4ppxzo>
25. Finkbeiner D.P., "WMAP Microwave Emission Interpreted as Dark Matter Annihilation in the Inner Galaxy", January 2005, <http://www.arxiv.org/abs/astro-ph/0409027>
26. Samanta-Laughton M., *Punk Science*, *op. cit.*
27. Lerner E., "Bucking the Big Bang", *New Scientist*, 22 May 2004, p. 20
28. Chown M., "End of the Beginning", *New Scientist*, 2 July 2005, pp. 30-35
29. Starkman G.D. and D.J. Schwarz, "Is the Universe Out of Tune?", *Scientific American*, August 2005, pp. 36-43
30. Merali Z., "'Axis of Evil' a Cause for Cosmic Concern", *New Scientist*, 13 April 2007, p. 10
31. Finkbeiner D.P., *op. cit.*
32. Geffer A., "Liquid Universe", *New Scientist*, 16 October 2004, pp. 35-37
33. Rutledge R.E. et al., "Chandra Detection of an X-ray Flare from the Brown Dwarf LP 944-20", *The Astrophysical Journal Letters*, 1 August 2000, vol. 538, no. 2, pp. L141-L144
34. Reich E.S., *op. cit.*
35. NASA, "NASA's Fermi Telescope Finds Giant Structure in Our Galaxy", 9 November 2010, <http://tinyurl.com/245h4f6>

OUT NOW



HARD HITTING & FASCINATING ARTICLES BY LEADING RESEARCHERS INCLUDING LYNNE PICKNETT, CLIVE PRINCE, BILL CHALKER, LEN KASTEN, JOHN LAMB LASH & MICAH HANKS.

EXCLUSIVE INTERVIEWS WITH NICK REDFERN & JOHN WHITE...

**New Dawn Special Issue 17
(Spring 2011)
is now available for \$8.95
from newsagencies
around Australia & New Zealand.
To purchase e-book version,
visit www.newdawnmagazine.com**

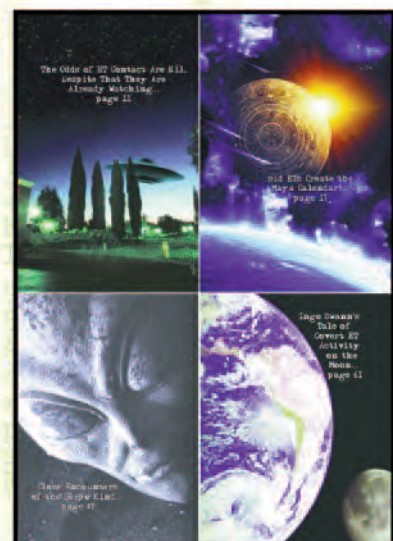

Call **1300 364 935** or visit www.michaeltzarionaustralian tour.com

ARCHITECTS OF CONTROL

MICHAEL TSARION

FIRST AUSTRALIAN TOUR

MELBOURNE
19TH NOV

SYDNEY
20TH NOV

ADELAIDE
26TH NOV

GOLD COAST
27TH NOV

PERTH
3RD DEC

The transhuman agenda, occult symbolism, and the end of evil



ALPS WATER FILTER - Ph: 07 40325820, 0448856988



*Certified Fluoride Removal (<0.1 mg/L F) plus other contaminants

*Simulation of natural water way, via a simple and affordable nine stage process

*Genuine after sales service and provision for replacement of components as required

* \$235 – 14L Unit, \$295 – 20L Unit (+ post) -- PO Box 312 Westcourt 4870 QLD --

We have a wide range of **Nutritional Supplements** at competitive prices:

Benfotiamine – a superior form of Vitamin B1, wide application \$40 - 250mgX120vcaps

Nattokinase (fibrinolytic enzyme) - cardiovascular health - \$30 - 90vcaps x 2000 FU's

PABA - important B complex vitamin, **special price**, \$11 - 100 caps x 500mg

Gymnema Sylvestre (herbal) – blood sugar levels, \$35 – 90 caps x 400mg

Mushroom Immune Defence – 16 mushroom complex , \$35 – 60 tabs

Bitter Melon – blood sugar & cholesterol **special price**, \$20 – 100 caps X 450mg

For a full product range please contact above or at info@ndnutritional.com.au

OUTER SPACE SECURITY AND DEVELOPMENT TREATY 2011

This is a pivotal moment in history when we can ban space-based weapons before an irreversible momentum of funding and vested interests makes them impossible to stop. A new Treaty to ensure peace in space is an urgent priority.

from Dr Carol Rosin
Founder
Institute for Security and
Cooperation in Outer Space
(ISCOS)

Website:
<http://www.PeaceinSpace.com>

Welcome to Peace in Space

The Outer Space Security and Development Treaty of 2011 establishes a framework and procedures to assure that space will be a neutral realm from which all classes of weapons are banned and from which no hostile action shall be taken toward Earth or the surrounding Cosmos.

This Treaty invites Nation States to become Signatories to this Treaty and invites Parties, including Nation States, Indigenous Nations, and Cosmic Cultures to commit to plan and assist in the orderly development and implementation of a framework and procedures that will assure and verify that space is and will remain a neutral realm from which all classes of space-based weapons are banned in perpetuity.

This Treaty will put a lid on the war industry and mindset while allowing it to be transformed. It recognizes that information and data gained and shared from cooperative space exploration and development will provide unlimited benefits and opportunities to all humankind in areas of health, education, the economy, mutual security, energy, and the environment... as wars end.

Together, we can and will get this Treaty signed into world law!

The Parties to this Treaty:

Reaffirm the urgency of preventing a destabilizing, threatening, and costly arms race in space,

Recognize that an agreement by Treaty to create a weapons-free space domain to ensure universal cooperation in space will save huge sums that would otherwise be expended for a dangerous and provocative space arms race,

Recognize that eliminating space-based weapons is more easily accomplished by agreement before any further investment is made to place them in position,

Confirm that it is the obligation of all State leaders to ban all space-based weapons including the intention to weaponize space, the moon or any celestial body or to use any space-based technology as a space-based weapon,

Reaffirm the urgent need for agreements on concrete proposals and projects deriving from confidence-building, world-cooperative space ventures which will prevent an arms race in outer space,

Recognize that information and data gained from cooperative space exploration and development will provide unlimited benefits and opportunities to all humankind in areas of health, education, the economy, mutual security, energy, and the environment,

Acknowledge that we are not alone in the universes, that there are Cosmic Cultures that will be important allies for our security and development, and that our national and international policies must reflect this reality,

Acknowledge that from the beginning of nuclear weapons testing, extraterrestrial craft have demonstrated a capability to selectively shut down communications and/or the power of participating operational units, and have appeared over ICBM fields in several countries causing non-destructive failure of

dozens of ICBMs—taking them out of operational status for days,

Realize that the demonstrated capability of extraterrestrial cultures from the multiverse to neutralize any missile or nuclear capability is in itself not a threat message, but does serve notice of our limited understanding of physics and the clearly dangerous consequences of continuing to use destructive technologies,

Affirm that the possibility of reclaiming a peaceful future for humankind and a safe environment on Earth is intimately linked with curbing our violence toward each other and Earth, and with preparing to survive as Gaea heals herself, and that counsel and support from Cosmic Civilizations thousands of years our senior would be exceedingly helpful,

Note that every class of space-based weapons, including weapons of mass destruction or precise destruction, is a symbol of fear for which violence provides no remedy,

Recognize that space must forever be free of man-made hazards, and must be a passageway to the secrets of our past and the challenges of our future,

Are inspired by the great prospects of Earth taking its rightful place in the Cosmos and the citizens of off-Earth realms sharing the fruits of their cultures with humankind,

Reaffirm that preventing placement of space-based weapons will avert resulting consequences, risks, and dangers to peace on Earth and to peace in space,

Believe that world cooperation in space will contribute to developing mutual understanding and to strengthening security based on a new form of verification and enforcement that applies the latest tools of technology for observation and information sharing because cooperative relations build more trust and transparency,

Understand that this space Treaty is now verifiable and enforceable via applying monitoring, observation, and information-sharing techniques both existing and forthcoming,

Are inspired by the great prospects, benefits, and opportunities for stimulating economies, jobs, profits, products, and services to solve urgent and potential problems of humans and the rest of the biosphere,

Recognize that our space assets can be protected only by mutual cooperation and verification, and that this Treaty will accomplish this objective,

Realize we are one interconnected and interdependent human species, and we are determined to live in peace with

all our neighbors on Earth and in the universes,

Affirm that it is the policy of the Parties to this Treaty to permanently ban all space-based weapons and to proceed into space cooperatively,

Are convinced that this Treaty will further the purposes and principles of the Charter of the United Nations.

The Nation States Signatories to this Treaty agree to the following Articles.

Article I

1. Each Nation State signing and ratifying this Outer Space Security and Development Treaty of 2011 shall:

(a) Implement a ban on the research, development, testing, manufacturing, and deployment of all space-based weapons;

(b) Implement a ban on the use of space-based weapons, the purpose of which is to destroy or damage objects or beings located in space or on Earth;

(c) Terminate any current research, development, testing, production, manufacturing, and deployment of all space-based weapons;

(d) Support and encourage other Nation States to sign, ratify, and implement the Outer Space Security and Development Treaty of 2011.

2. After the first nine (9) Nation States sign and ratify the Outer Space Security and Development Treaty of 2011, the Secretary General of the United Nations shall submit to the General Assembly of the United Nations the official recognition of this Treaty henceforth as ratified law.

3. Nothing in this Treaty shall prohibit the following space-based ventures that are not activities related to space-based weapons:

(a) Space exploration; (b) Space research and development; (c) Testing, manufacturing, production or deployment of non-weapons systems.

4. Not prohibited are commercial, civil, entrepreneurial or military space-based ventures that are confirmed by the Peace in Space Office not to be any part of a space-based weapon system or to have no intention to become or support a space-based weapon or system.

5. Cooperative space-based ventures with any peoples on Earth or with members of any Cosmic Culture are encouraged.

Article II

1. Each Nation State Signatory to this Treaty shall not base any weapon on any object or celestial body located in space. Permitted is the establishment of space-based related military bases or operations, including for

“Realize that the demonstrated capability of extraterrestrial cultures from the multiverse to neutralize any missile or nuclear capability is in itself not a threat message...”

communication, navigation, reconnaissance, early warning, remote sensing, and surveillance that does not interfere with operations of any other satellites, with living and working in space, or with space ventures, provided that it can be verified by the Peace in Space Office that there is no intention to use any space-based technology or system as a space-based weapon.

2. The use of military technology or personnel for peaceful space-based purposes that do not use any equipment or facility in space related to the research and development, testing, manufacturing, production, deployment or application of space-based weapons is not prohibited.

Article III

1. Nation State Signatories to this Treaty agree to the establishment, equipping, and organizing of a United Nations Peace in Space Office.

2. This Peace in Space Office shall be composed of representatives from diverse areas such as commercial, civilian, entrepreneurial and military sectors that will check registration of space ventures and determine methods for monitoring compliance, including verification and enforcement measures that will maintain the permanent commitment of all Nation State Signatories to this Treaty.

3. The Peace in Space Office is mandated to monitor outer space to verify and to enforce this Treaty using the latest tools of technology and information sharing.

4. The Peace in Space Office will identify any entity or program that engages in activities contrary to the provisions of this Treaty and will work with all signatories to correct this situation via cooperation, not confrontation.

Article IV

1. The term "space" [or] "outer space" is defined as the space extending above the Earth at an altitude of 100 kilometers above sea level. Weapons banned by this Treaty are considered to be space-based if they are located at or above 100 kilometers above sea level.

2. Space-based weapons are defined as being anything that is based in space that can be used to damage or destroy objects or beings in space or on Earth from a location based in space.

3. This Treaty bans all space-based weapons, including the dual-use of any space-based object or technology when it is located in space with the intention to be used as a weapon that could damage or destroy any object or being on Earth or in space.

4. Weapons launched from the Earth that travel through space but are not based in space are not banned by this Treaty.

5. The terms "space-based weapon" and "space-based weapons systems" are defined for the purpose of this Treaty in order to identify weapons, devices or systems that are based in any space location for the purpose of damaging or destroying, from space, any object or being that is located in space or on Earth.

6. This Treaty prohibits:

(a) Firing one or more weapons based in space that would be intended to collide with any object or being in space;

(b) Detonating any explosive device based in space in close proximity to any object or being in space;

(c) Directing any space-based source of energy offensively against any object or being in space or on Earth;

(d) Basing controls or systems of any space-based weapons that are or could be intended to collide with or inflict damage upon objects or beings in any location in space including on the moon, any celestial body, on a satellite, craft, station, or on any Off Planet Visitor craft.

“The Cosmic Culture Liaison will assist in identifying and neutralizing any attempt to deploy or use any space-based weapon.”

Article V

1. The United Nations Office for Outer Space Affairs shall be responsible to coordinate the first meetings between members of Cosmic Cultures with units of the United Nations and representatives of Signatory Nation States and Indigenous First Nations.

2. A permanent Cosmic Culture Liaison will be available to the United Nations Security Council to answer questions and to provide counsel on issues of security and development of Earth.

3. The Cosmic Culture Liaison will assist in identifying and neutralizing any attempt to deploy or use any space-based weapon.

Article VI

1. The provisions of this Treaty that ban all space-based weapons shall apply to all Nation States, whether or not they are Signatories to this Treaty.

2. This Treaty shall enter into force upon the signing and ratification of the first nine (9) Nation State Signatories.

Article VII

1. This Treaty shall be open to all Nation States for signature. Any State that does not sign this Treaty before its entry into force may accede to it at any future time.

2. This Treaty shall be subject to ratification by Signatory Nation States. Instruments of ratification or accession shall be deposited with the Secretary General of the United Nations.

3. This Treaty shall enter into force upon the deposit of instruments of ratification by nine (9) Governments. For any Nation State whose instruments of ratification or accession are deposited subsequent to the entry into force

of this Treaty, their ratification shall enter into force on the date of the deposit of their instruments of ratification or accession.

4. The Depositary Governments shall promptly inform all Signatory and acceding Nation States of the date of each signature, the date of deposit of each instrument of ratification of and accession to this Treaty, and the date of its entry into force and other notices.

5. This Treaty shall be registered by the Depositary Governments pursuant to Article 102 of the Charter of the United Nations.

6. This Treaty shall be of unlimited duration.

Article VIII

1. Any Nation State Signatory to the Treaty may propose amendments to this Treaty.

2. Amendments to the Treaty shall enter into force upon acceptance by a majority vote of the Nation State Signatories.

3. The text of any proposed amendment shall be submitted to the United Nations Depositary who shall promptly notify all Nation State Signatories.

Points of Clarification

1. This Treaty does not ban weapons located on Earth.

2. This Treaty bans the "weaponization" of space. The "militarization" of space, which has occurred, requires a new definition for the purposes of this Treaty. Militaries already provide enhanced intelligence and communication, observation and data sharing, and can help to pave a safe way for humans to enter into the universes and for members of Cosmic Cultures to enter the Earth sphere safely.

3. The strategy of this Treaty incorporates the reality that humans have evolved into a condition of much higher consciousness than that of the past, and that we will be working with Cosmic Cultures whose situation and willingness to cooperate with Earth cultures is based upon that higher consciousness. The Signatories of this Treaty acknowledge this viewpoint because it is necessary to work within the context of the highest truth in our time, and because this is the only approach that will garner the support needed to enact this Treaty.

This Plan of Action Calls on All World Citizens to:

1. Immediately email the sample letter or your own "Dear President" letter. The talking points on the Plan of Action page may give you some ideas to present in your personal letter. Send all letters to spacetreaty@gmail.com with your name and contact information. We will include your letter in a package of information that will be given to

country presidents. (Your name and contact information will not be distributed to any lists.)

2. Go to the website <http://www.PeaceinSpace.com> for more information, including about the Treaty signing and the World Tour and Documentary.

3. Distribute copies of the Treaty to media and network it around the world as part of a grassroots Call to Action to get this Treaty signed into law that bans *all* space-based weapons forever and acknowledges the peaceful existence of Cosmic Cultures. Download a copy of the Treaty from <http://www.peaceinspace.com/the-treaty>. ∞

About the Treaty's Co-Authors:

For more details about the Treaty's co-authors, listed below, go to <http://www.peaceinspace.com/about-us>.

• **Dr Carol Rosin:** ISCOS founder Dr Rosin carries on the wish of her mentor, rocket scientist Dr Wernher von Braun, to ban weapons from space. An educator, humanitarian and a World Peace Ambassador, she is committed to world cooperation in space and to establishing a new space treaty.

“The strategy of this Treaty incorporates the reality that humans have evolved into a condition of much higher consciousness than that of the past...”

• **Paul T. Hellyer:** Trained as an aeronautical engineer, Paul Hellyer is a former Minister of Defence in Canada who oversaw the integration of armed services into the Canadian Forces. An advocate of global UFO disclosure, he introduced a previous Treaty to ban space weapons.

• **Dr Cecil B. (Scott) Jones:** A retired US Navy Commander with a background in overseas and national intelligence service, Dr Jones is founder of the Peace and Emergency Action Coalition for Earth (PEACE),

which oversees the development of the Center for Sustainable Peace and Development. He encourages dialogue among leaders about what UFO disclosure will mean to each country and culture.

• **Abe Kriger:** A former Boeing structural engineer and business development manager, Abe Kriger helped set up the Boeing–Russian Space Cooperation Program ahead of the International Space Station and was program manager for the Global Nuclear Spent Fuel Storage and Logistics Feasibility Study. In retirement, he has led initiatives in mental health care and affordable housing.

• **Commander Will Miller:** A retired US Navy officer and decorated veteran, Cdr Miller is a former adviser to the US Space Command, Dept of Defense and White House staff and a senior analyst in counter-threat planning. He was a senior Technology Support Officer with the US Atlantic Command and served on the Advisory Board for Space Cooperation and Development.

• **Dr Edgar D. Mitchell:** An aeronautics/astronautics engineer, Dr Mitchell is a former US Navy captain, test pilot and NASA *Apollo* astronaut—the sixth man to walk on the Moon. The founder of the Institute of Noetic Sciences in 1973, Dr Mitchell is dedicated to exploring consciousness, raising human potential, implementing societal alternatives and pursuing strategies for a sustainable future.



i4cMwo
Pty Ltd
AUSTRALIA



Supplements

- * Heart Pal 250 gm Jar \$30.00 (Dr Linus Pauling formula for heart health)
- * MSM 250gm Jar \$20.00 (Methyl Sulfonyl Methane-Essential for total body health)
MSM 1kg Bag \$50.00 2kg Bag \$80.00
- * CoQ-10 100mg 60 Capsules \$30.00 (Cellular energy) or 2 for \$50.00
- * Zeolexx 250gm Jar \$45.00 (Zeolite+Beta-Glucan)-(General health, Immune boost,Detox)
- * Nattokinase 90 Capsules \$35.00 (Blood vessel health)
- * Serrapeptase 90 Capsules 40,000 U \$30.00 (Inflammation reduction)
- * Melatonin 100 Tablets 3 mg \$24.00 (Sleep aid)
- * iP-6 90 Tablets 800mg \$30.00 (Inositol Hexaphosphate Supports Breast, Colon and Prostate)
- * 12 Organic Mushrooms 500mg 60 Capsules \$20.00 (Immune system support)
- * 5-HTP, Gaba, Magnesium Glyconate, Ascorbic Acid, Resveratrol, Cordyceps
And many more available at our website.
- * E-Cigarettes prices start at \$25.00 E-Cigars- E-Pipes (An aid to stop smoking)
<http://www.bodyformulas.com>

The best available at the best prices Ph: 07 5433 1900

Morayfield Queensland www.i4cau.com

keith@zeolexx.com

You too can enjoy the proven health benefits of clean indoor ionised air!



Air Purifier/Ioniser

with Swedish tested and proven technology, to eliminate most dangerous health allergens associated with dirty indoor air.

Proven and tested to remove up to 98% of:

- DUST MITES • BACTERIA
- PET DANDER • AIRBORNE MOLD
- VIRUSES • POLLEN ALLERGENS

LightAir Ionflow 50 Air Purifier/Ioniser for protection of your family's long term health and wellbeing.

lifeforce nature's

30day
MONEY BACK
GUARANTEE
must be returned
in original condition



LightAir Ionflow 50 Surface

**100%
GUARANTEED**

not to require any further ongoing maintenance costs. That's correct,
NO filter changes **EVER!**
NO needle replacements **EVER!**

SPRING SPECIAL

NOW **\$467.** SAVE \$30 OFF RRP
only till stocks last plus delivery

2 YEAR WARRANTY
Guaranteed not to produce ozone

call now: 1300 009 991

P: 03 8626 9696 E: info@naturelforce.com.au
www.naturelforce.com.au

The leading name in **air ionisation** for over 45 years announces exciting new innovations...

ELANRA.

Medical Negative Ionisers

While many Aussie companies are moving their manufacturing plants overseas, Elanra ionisers are manufactured solely in Australia but sold all over the world. We ensure our meticulous standards are upheld through every step of the manufacturing process, so that every purchaser can have full confidence in the famous quality and reliability of Elanra ionisers.

While other companies are cost-cutting, Bionic Products has invested heavily to upgrade to new **Space Age Technology**, employed in the production of the next generation of Elanra ionisers. Our contracted manufacturer is the only company in Australia certified to build to AS9100 standard. The plant produces components for NASA and military spacecraft. Using advanced surface-mount technology, all Elanra units are assembled to RoHS standards, ensuring no lead, cadmium or other toxic elements are present in any Elanra ioniser.

In addition, Elanra's advanced micro-electronic circuit boards are coated in 22K gold. Despite the soaring cost of gold (now around \$1,890.00 oz.) our policy of 'only the best will do' ensures we will not drop our standards to save a few dollars. The exceptionally high quality of each Elanra unit allows us to offer **A Ten Year Guarantee on manufacturing and components** for every Elanra ioniser sold from 1st September 2011. Your manufacturer's warranty covers normal usage and operation for an incredible ten years from the date of purchase!

Invented by an Australian!
Fully patented technology!
Proudly manufactured
in Australia!



Take the Air Ions Sensitivity Test...

- Are you often drowsy or easily fatigued?
- Do you have itchy eyes?
- Do you suffer from a dry, scratchy throat?
- Do you take an hour or more to unwind after work?
- Does air conditioning upset you?
- Do you have blocked nostrils or raspy breathing?
- Does a wind change affect you?
- Do you feel irritable and lethargic before a storm?
- Do you sleep 7 or 8 hours, yet still wake up tired?
- Do you have dryness, burning or itching of the nose?
- Do you find it hard to concentrate?
- Do you find the air in your workplace stuffy and stale?
- Do you fall asleep in front of the TV?
- Do you have a ticklish cough or need to clear your throat several times a day?
- Do you often become drowsy while driving?

If you answered YES to three or more of these questions...

ELANRA may be of benefit to you!

Understanding Negative and Positive Ions

Recall how good it feels to stroll on the beach, go hiking in the mountains or sit by a rushing waterfall while breathing in clean fresh air amid the beauty of nature. The real secret to these 'good feelings' is that air in these environments is not only free of pollutants, it is alive with electrical activity from positively and negatively charged molecules called ions. An overabundance of positive ions is harmful to the well-being of all creatures, so nature carefully balances the quantities of positive and negative ions to an optimal level.

Negative ions can be considered the 'good' ions. They occur in all sizes and are electrically attracted to airborne particles such as dust, mould spores, fumes, viruses and bacteria. They attach to these and precipitate them onto the nearest surface, thus cleaning the air of pollution and germs. But this is only one aspect of negative ion activity.

As we breathe, the smallest negative ions of oxygen enter the bloodstream via the lungs to circulate throughout the body. Decades of research by scientists in various countries has shown that these tiny negative ions are bio-active, exerting a beneficial effect on the mood and well-being of living creatures to reduce stress, accelerate healing and promote restful sleep.

Research carried out at La Trobe University in Melbourne demonstrated that the smallest negative ions boost the production of Immunoglobulin-A, providing the immune system with extra power to fight off illness and infection. Breathing in small negative ions can also aid concentration and reduce the irritation of allergies.

Until the 1980s there was no way to replicate nature's air ion balance via a safe and reliable method. Ionisers could only produce large negative ions that simply clean the air. After years of painstaking research, technological advances enabled Joshua Shaw to reproduce nature's small negative ions and the unique Elanra ioniser was born.

Elanra is the world's only ioniser specifically designed for therapeutic use. Further, it is the only one that can be programmed to operate at a range of pre-set frequencies for optimal therapeutic benefit. Elanra ionisers comply with all international electrical and safety standards and are included in the Australian Register of Therapeutic Goods (ARTG 138924).

Elanra MkII

The MkII is the preferred ioniser for two people sharing a bedroom or for a large open living or work space in the home. Also recommended for consultative environments such as a medical or dental practice.

Facts and Specifications

- Australian owned and manufactured
- Therapeutic range of 2m
- Air cleaning capability of 75m²
- Over 144 individual settings
- Pre-programmed for the individual user
- Can be reprogrammed to suit changing needs
- Micro processor controlled circuitry
- Surface mounted components
- Undetectable ELF fields/ozone emissions
- Special casing doesn't outgas - safe for allergy sufferers
- Able to be used anywhere in the world
- 10 year guarantee

Rewarding Our Customers...

We love to reward our faithful customers who use and recommend Elanra ionisers.

From 1st September 2011 our customers can receive up to **25% Discount** on their purchases.

Previous customers who purchase a new or additional Elanra ioniser will automatically qualify for: **25% Discount**

Purchase 2 or more Elanra products: **10% Discount**

If you are a member of a Medical Fund or purchase on referral from a Medical Practitioner or Health Care Professional: **15% Discount**

Age or Veteran pensioner, Seniors card holder, Health Care Card holder, Student, Teacher, Lecturer or Airline Employee: **20% Discount**

Phone toll-free 1800-074-844. Or, visit us at www.negativeions.com

Marine Phytoplankton

'The Revolutionary Super Food for Extraordinary Health'

Marine Phytoplankton. A nutritional powerhouse created by Mother Nature.

Marine Phytoplankton contains hundreds of potent phyto-chemicals working in synergy to nourish your body at a cellular level enhancing oxygenation and circulation.

Marine Phytoplankton serves as a valuable source of nourishment including Omega 3, 6, 7 & 9.

This 'Conservation Grade Marine Phytoplankton' is grown in Photo-Bioreactors, avoiding the depletion of our precious ocean of a vibrant resource.

Powder (20gm) \$44.95



Inner Glow

Order direct from
Inner Glow Health Products
Telephone: 07 5449 0600
www.innerglow.com.au

ZAKAY gallery
GLASS CREATIONS

The Cube Light

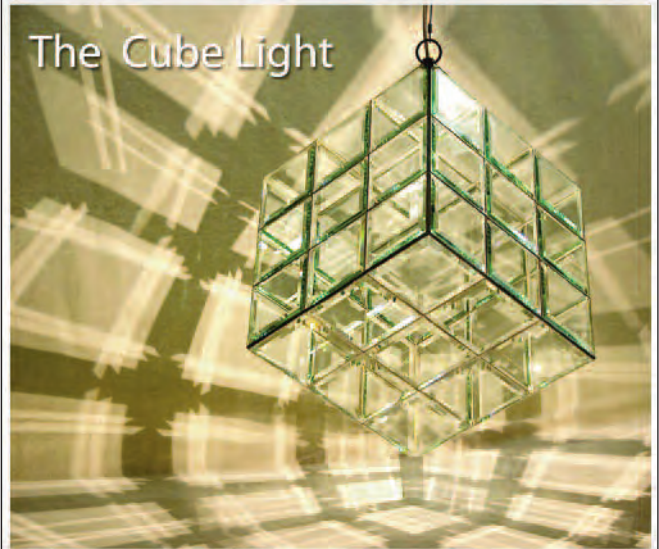

Visit our gallery, studio and online store
open Mon-Fri 10am-5pm Sat 10am-4pm
6/102 Centennial Circuit, Byron Bay, NSW
zakayglasscreations.com 02 6685 6225

NEXUS DVD UPGRADE

The complete back catalogue of NEXUS Magazines on DVD.

- ◆ This DVD contains all magazines from 1987-2010 in PDF format.
- ◆ Files are text-searchable, meaning you can simply pop the DVD into a computer and use your search function to find keywords or strings of text.



To order, go to www.nexusmagazine.com

THE PROMISE OF FIBRE DIFFRACTION DIAGNOSIS

Fibre Diffraction Diagnosis (FDD) is a method for detecting cancer using X-rays of hair, nail clippings or skin. This invention can reliably reveal the presence of many serious diseases, including prostate, breast and colon cancer, melanoma, Alzheimer's disease and insulin dependence.

Early diagnosis of these diseases can be the difference between life and death, and the creation of a non-invasive test that is accurate and can be easily undertaken has the potential to save countless lives.

A Significant Discovery

We've come a long way in the treatments available for people with cancer, but early diagnosis is crucial to people's chances of survival. Until now, there have been no reliable, non-invasive diagnostic tests for some of the most common and aggressive forms of cancer.

Professor Veronica James stumbled upon a massive discovery almost by accident when she noticed that certain patterns in people's hair can reveal the presence of a number of diseases, including cancer and Alzheimer's disease.

This was one of those totally serendipitous discoveries. In 1996, Prof. James reported to the medical personnel at Christie Hospital, Manchester, the four changes she had observed in the collagenous ductal tissue of the breast which precede breast cancer, noting that, in the final stage, the breast tissue had reversed to foetal tissue. Prof. James was asked whether she had observed similar foetal tissue in the skin as had been reported in breast cancer.

A subsequent study at the local Daresbury synchrotron of 14 skin samples did show a possible foetal-like change similar to the penultimate change in the breast. Christie Hospital oncologists agreed to provide 200 samples to confirm these results, but when James arrived in England to collect them, the samples had disappeared from their freezer.

As Prof. James had already studied changes in hair in insulin-dependent diabetes and was due in Japan the following day, she asked if a clinic was in progress and, on being told that it was, asked if a hair sample could be taken from each of the participants. With hoots of laughter they agreed, asking her what she thought she would find. She told them nothing, except that she would not be in disgrace in Japan for arriving without any samples. They were still laughing when she collected these samples the next day.

When Prof. James started to look at the samples the following day in

Japan, she found strange rings superimposed on the normal hair patterns; and after blaming and reassembling the machine, she found that only eight of the 19 samples showed this ring. Prof. James sent back to England the numbers of these samples, thinking that they might have something in common—same family, same shampoo, same hairdresser, etc. Their return email stated simply that she had picked out all the breast cancer patients.

This was confirmed by taking these and further blinded sets to other synchrotrons. The changes relating to other cancers and Alzheimer's disease were found in the 4,000 subsequent blinded tests from 14 different international sources when patients with other cancers were included to prove that the discovered change was specific to breast cancer.

As each new change was identified, further studies were undertaken to verify the specificity of each of these new changes.



How It Works

This method of diagnosis is quite revolutionary and has been greeted with some scepticism by scientists. Professor James maintains that her results can be easily duplicated if the correct procedures are followed.

Basically, what Prof. James is doing is taking a sample of hair, nail or skin and shining an X-ray beam through it. Upon examination of the X-ray, one can observe rings which in their various positions indicate if the patient is developing a particular type of cancer. An absence of rings indicates the patient is healthy.

Professor James claims that cancer can be detected very early using her method.

(Source: The New Inventors, ABC TV, Australia, 10 June 2010, <http://tinyurl.com/3zqqwuk>)

FIBRE DIFFRACTION TESTING

by Professor Veronica James
© 2011

My fibre diffraction tests are based on straight physics practices of crystallography. In fact, the same procedures were utilised by Rosalind Franklin to obtain the pictures used to solve the structure of DNA.

This technique bounces a finely focused X-ray beam off the electron distribution within the specimen. If there is a repeating arrangement of atoms within the sample, a pattern specific to that arrangement will be obtained on the screen. Hence, the pattern obtained for any mammalian hair will be the same, with minor variations depending on the diameter of the hair and the hair content. (In *Cancers* 2010; 2:1155-65, I provide a selection of such patterns.)

As a rule, all patterns for similar animals will be the same. This technology is used routinely to test for drug use, poisoning, etc.

For example, all persons suffering from, say, lead poisoning would show the same changes to the normal pattern. This change results from extra lead in the blood in which the keratin molecule is assembled. Similarly, specific changes result from any other addition to the material.

In my tests for breast cancer using hair, nails or skin, a specific change

This change is a ring of specific diameter, superimposed on the pattern of either keratin or collagen respectively.

is superimposed on the pattern obtained for normal tissue. This change is a ring of specific diameter, superimposed on the pattern of either keratin or collagen respectively. This change appears as soon as the body's blood flow goes through the cancer. It also disappears when the cancer is removed either by surgery or chemotherapy.

Specific changes in the fibre diffraction diagnosis (FDD) patterns for hair and nails have also been established for patients with colon cancer, insulin-dependent diabetes and Alzheimer's disease, while specific changes in the FDD pattern of skin have been established for melanoma and prostate cancer. The effects of ageing have already been established.

All the changes associated with cancers are rings of diameters specific to the particular cancer, with variations even between the gene- and non-gene-related breast cancers. If a person has two different types of cancer, both rings will be present.

The presence of beta-amyloid in Alzheimer's disease shows up as crystalline spots in specific locations. Again, such spots will appear in addition to the specific change associated with the specific cancer if both are present.

In the case of breast cancer, I have studied over 4,000 samples with no false negatives. Some false positives have been obtained with an overall accuracy for all samples of 98 per cent. Some "false positives" have subsequently been shown to be correct. This results from the fact that the FDD diagnosis dates from the very start-up of the cancer, while mammography can only pick up the cancers at a later stage of growth—three years later in one case where the woman died six months after the breast cancer was diagnosed by mammography. If they had acted on my first diagnosis, she would have been saved.

For Alzheimer's, melanoma, colon cancer and prostate cancer, results were as above, but the number of samples was between 50 and 100; larger tests are being arranged.

My latest results with prostate cancer would indicate two separate changes for high-grade and low-grade (benign) tumours. At present, the investigative process for diagnosing prostate problems involves serial PSA (prostate specific antigen) readings, ultrasound testing and prostate biopsies, which are particularly invasive procedures requiring general anaesthetic and up to 20 or sometimes 30 core biopsies of the prostate.

The risk of infection, incontinence and other problems following these procedures is significant, and the post-operative recovery takes a variable amount of time depending on other co-existent patient demographic factors.

This PSA test is less than 50 per cent accurate. These results explain why prostate cancer is now

responsible for more deaths in men in Australia than deaths in women from breast cancer. Results already published show the change for high-grade prostate cancer that is Gleason-graded greater than 4.0.

A murine study shows that we can pick up this change at a much earlier stage than with any other biochemical or pathological test.

(Source: Letter from Professor Veronica James to the Editor, September 2011)

USING HAIR TO SCREEN FOR BREAST CANCER

US Patent 6718007,
issued 6 April 2004

Field of the Invention

The present invention relates to a method of testing the presence of a gene responsible for a pathological state, or the pathological state itself, in biological material in which the molecules are regularly arrayed.

Specifically, the present invention (see figure 1) relates to analysing hair for detecting the presence of BRCA1 gene, the presence of breast cancer *per se*, the presence of prostate cancer and a confirmatory diagnosis for Alzheimer's disease.

Background

Breast cancer is still a major cause of death in women in Australia. It has been established that approximately 14% of Australian women will have it during their lifetime. However, if the cancer is diagnosed early enough, while it is still contained within the breast, there is approximately 98% chance of obtaining a total cure. An early low-cost diagnostic tool would be a major breakthrough in this area of medicine.

The genes responsible for familial breast cancer have already been located and clinics are being formed to closely monitor those whose family members have been shown to

test positive to the gene. These tests, however, take weeks to complete, are extremely costly and cannot be extended to all women and are at present limited to the high-risk group of persons whose mothers had breast cancer. At present, a very expensive and time-consuming test is used to determine the carriers of genes, such as breast cancer genes.

The technique of this invention provides a relatively low cost, approximately one-minute alternative test. It also offers a possible mass screening technique, for example, for breast cancer *per se*, with easy access to sample collection and handling.

Such a test may replace mammography, which is not only expensive, requires attendance at various locations and from the woman's point of view is quite painful but also is not 100% reliable and in some cases is very difficult to interpret.

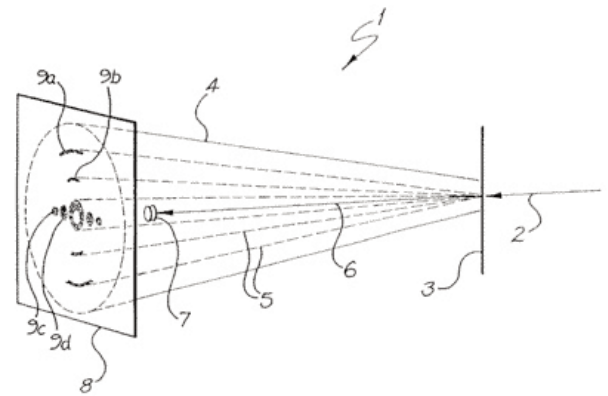

FIG. 1

Figure 1: Schematic representation of the X-ray analysis system of this invention.

Summary of Invention

Considered at the microscopic level, a single hair consists of a core (the medulla) surrounded by an intermediate layer (the cortex) and then by a thin outer envelope (the cuticle). The cortex can be considered as a continuous network of alpha-keratin fibrils arranged parallel to the length of the hair and held together by a cell membrane complex.

During keratinisation in the follicle, each individual cortical cell is wrapped in a plasma membrane, which is basically a biomolecular layer of phospholipids, which acts as the adhesive between neighbouring cells. Such a regular array is ideally



suiting to fibre X-ray diffraction analysis, and the ultrastructure of human hair has been previously determined from high-intensity synchrotron radiation scattering data combined with results from physical swelling and stretching experiments...

Low-angle fibre X-ray diffraction along with appropriate analysis will yield the molecular structure of any material in which there is a regular array of molecules. Hair is such a material, characterised by regular arrays of alpha-keratin. Studies using synchrotron radiation have not only yielded the structure of alpha-keratin *per se* and that of the specific alpha-keratin in hair but have also revealed and identified the molecular changes that occur in human hair in insulin-dependent diabetes.

It has now been surprisingly found that fibre X-ray diffraction studies using synchrotron radiation can reveal clear and consistent changes in the ultrastructure of hair from breast cancer patients.

According to a first aspect of the present invention, there is provided a method for detecting the presence of a gene responsible for a pathological state, or the pathological state itself, in a patient comprising exposing at least one hair to fibre X-ray diffraction and detecting changes in the ultrastructure of the hair.

According to a second aspect of the present invention, there is provided an instrument for detecting the presence of a gene responsible for a pathological state, or the pathological state itself, using a hair sample, comprising: an X-ray source producing a beam of X-ray radiation, a sample stage for positioning said hair sample within said beam, a detector to detect the scattering of said X-ray beam caused by said hair sample, and a display means associated with said detector for

displaying the output thereof, whereby patterns of output related to the presence of said gene or said pathological state are displayed for interpretation.

Suitably, the X-rays used are derived from synchrotron radiation or other monochromatic X-ray sources, providing X-rays within the energy range of 5.0 to 25.0 keV.

In practice, a single hair is taken from adjacent to the scalp or other areas such as the pubic area of a person. The sample is washed in distilled water and dried under normal conditions (temperature 20 degrees Celsius, and atmospheric pressure), and then cut into approximately 30-mm lengths.

...fibre X-ray diffraction studies using synchrotron radiation can reveal clear and consistent changes in the ultrastructure of hair from breast cancer patients.

The specimen is mounted in a cell, under sufficient tension to maintain alignment. The cell is then placed on a low-angle diffractometer so that the sample is normal to the beam. The space between the sample and the imaging plate is evacuated so as to minimise absorption losses and air scattering.

The X-ray diffraction experiments are carried out using a monochromatic X-ray source, such as a low-angle synchrotron facility, for example at B115, Photon Factory, Tsukuba, or the like, with an X-ray wavelength ranging between 0.06 and 0.20 nanometres (nm).

An incident flux at the specimen of approximately 8.0×10^{10} photons/second can be generated when the Photon Factory storage

ring is operated at 25 GeV with a beam current of 145 mA. A 0.15-nm wavelength was used at this facility.

The X-ray patterns are recorded on imaging plates. Exposure time for the hair sample is suitably between five seconds and five minutes using synchrotron sources, but may be days or weeks using other X-ray sources.

Preferably, the exposure time is approximately 60 seconds on second-generation synchrotron sources and 20 seconds on third-generation synchrotron sources. Sample to imaging plate distances are approximately 20 mm to 3,000 mm. Suitably, 400-mm are used...

Discussion

Although the number of samples investigated so far is in total over 400, the reproducibility of the results is most encouraging. The flexibility of this technique—and the fact that, using synchrotron sources, each sample takes seconds to measure and only minutes to interpret—makes for its possible use as a rapid and accurate diagnostic tool for breast cancer, prostate cancer and Alzheimer's disease.

It should be clear that the present invention will find wide applicability in the medical field, particularly in the area devoted to detecting the propensity of a subject to breast cancer, prostate cancer and Alzheimer's disease.

(Source: <http://tinyurl.com/3hycgjn>)

About the Author:

Adjunct Professor Veronica James, OAM, based on Queensland's Gold Coast, is attached to the Australian National University's Research School of Chemistry. She has been researching breast cancer since the 1980s. Professor James has an Order of Australia medal for her services to the deaf. To contact Professor James, email veronica.james@anu.edu.au.

INVESTIGATING THE “GHOSTS OF THE OCEAN”

From the late 1960s to the early 1980s, rapidly moving underwater objects and mysterious croaking sounds were reported by Soviet submariners. What was to blame: US Navy sonic buoys, unknown creatures or something out of this world?

by Paul Stonehill © 2011

Email:
rurcla@hotmail.com

The Soviet Navy's *Kvakeri* Research

The Cold War was raging at the end of the 1960s, and dangers for both sides of the ruthless (and frequently invisible) war lurked in the skies, on land and underwater. One particularly strange underwater phenomenon attracted the attention of the Soviet Navy's High Command. This mysterious phenomenon was discovered in the late 1960s.

Soviet nuclear-powered submarines encountered strange sounds emanating from moving objects at great depths. Listening to underwater sound is known as hydroacoustic monitoring, and Soviet monitors heard the strange signals that resembled frogs croaking. They dubbed the objects *kvakeri*, and the term was officially accepted in the Soviet Navy's documents. *Kvakat'* in Russian means "to croak".

It was the Soviet Minister of Defence, Marshal Andrei Antonovich Grechko, who ordered the creation of a special research team by the Intelligence Directorate of the Soviet Navy to investigate various paranormal phenomena such as the *kvakeri*.

Sergey Georgiyevich Gorshkov, a Soviet naval commander during the Cold War who oversaw the expansion of the Soviet Navy into a global force and at the time was Commander-in-Chief of the Soviet Navy and Admiral of the Fleet of the Soviet Union, spared no effort in research into this phenomenon that obstructed his navy's operations.

Consequently in the USSR, a special Top Secret research program into the *kvakeri* phenomenon was started in the late 1960s. It lasted through to the early 1980s. But it was not the only unusual underwater phenomenon of interest to the Soviet Navy.

The Commander-in-Chief ordered a series of oceanic expeditions to research the *kvakeri* and other phenomena. Soviet officers in the Top Secret naval research program performed their duties eagerly; they were well-educated and highly professional people. They continuously visited different Soviet fleets and collected all available information. The *kvakeri* were found to operate as far away as near the Philippines and in the northern seas close to the USSR, but they were most active in the Atlantic Ocean.

One such expedition in April 1970 involved the *Khariton Laptev*, a reconnaissance vessel code-named SSV 503 (the ship was removed from active service in 1992). This was precisely at the time that a Soviet nuclear submarine, the K-8, perished in the North Atlantic. The reconnaissance ship, which was participating in a secret mission, stopped its sonar operations, rushed to the submarine and was able to save many of the crew.

It is believed that the *kvakeri* had a particular interest in nuclear-powered submarines, as discussed later. However, the *kvakeri* research program was stopped abruptly when the phenomenon ceased to "bother" Soviet ships on special missions in the Atlantic Ocean.

So, what were those mysterious *kvakeri*?

A small Russian newspaper, *Podmoskoviye-Nedelya*, published a very interesting article in its 8 August 2001 issue. The author was Vadim Kulinchenko, a retired Soviet naval officer and submariner who had also been a senior officer in the Main Staff of the Russian Navy. He was the first former Soviet Navy officer to reveal details about the *kvakeri*. He said that the gist of the *kvakeri* phenomenon is similar to the UFO phenomenon: many have witnessed mysterious objects, but no one has been able to *prove* their existence. Kulinchenko recalled the stir created by reports of strange, unidentified noises that accompanied Soviet subs in their secret missions in unfriendly waters. It was as if the captains of underwater missile cruisers, returning from their missions in the Atlantic Ocean, had plotted to submit similar reports of peculiar noises. The nature of the noises was unknown to Soviet acoustics technicians.

Soviet Interest in UFOs, USOs and Sea Creatures

Other former Soviet military officers and researchers came to reveal more information in the following years about this very unusual phenomenon. Among them is the last Commander-in-Chief of the Soviet Navy and president of the Russian Union of Submariners, Admiral Vladimir Nikolayevich Chernavin, who commanded the Northern Fleet between 1977 and 1981. He stated that the instruction regarding UFOs and USOs, written by Vladimir Ajaja for the Soviet Navy (as part of the Soviet Union's highly secretive SETKA-MO UFO research program which functioned between 1978 and 1991), was not unique to the USSR: the Americans had similar instructions to collect information about anomalous (paranormal) phenomena. Admiral Chernavin knows that for a fact.

Vladimir Georgiyevich Ajaja, a prominent personality in the history of Russian UFO research, has been at the forefront of investigating USOs—unidentified submersible objects. He was awarded a Candidate of Technical Sciences (equivalent to a PhD in Engineering)—the first post-graduate scientific degree in many former Eastern Bloc countries, given for original research that constitutes a significant contribution to a

scientific field. When his urge to research and discuss the forbidden subject of UFOs got him fired from his job, it was the Soviet Navy that provided Ajaja with employment much more suited to his interest in paranormal phenomena. At one time in his arduous and tumultuous life, Ajaja served as the head of an underwater exploration expedition aboard the Soviet submarine *Severyanka*. Actually, Ajaja designed many features of the vessel. He and his fellow crew members once even observed a very unusual creature deep underwater: it looked like a lyre and had green tentacles. Yet there is no proof that Ajaja was privy to the secrets of *kvakeri* research.



Vladimir Georgiyevich Ajaja,
a prominent Russian UFO researcher,
author and former Soviet submariner

Some Soviet military researchers believed that the *kvakeri* were USOs. Yet most of the specialists in the research groups who had studied the phenomenon disagreed with this conclusion.

Nuclear submarines drove the Cold War's most furious phase of the arms race. According to Vice Admiral Viktor Patrushev, Chief of Operations on the General Staff of the Russian Navy and professor of the Academy of Military Sciences, the Soviets had built 243 nuclear submarines of various classes as well as over 1,000 diesel submarines. Some of these submarines must have really been of interest to the *kvakeri*, for the course and bearing indicators of the Soviet naval vessels demonstrated that the objects circled the subs and changed the frequency and tone of their signals.

The Soviets had never been able to establish the source of the sound. It came from

different sides, and the tone constantly changed. It was as if the objects were inviting the submarines to engage in "conversations". The *kvakeri* reacted especially actively, yet never aggressively, to the acoustic dispatches from the submarines. They would accompany Soviet submarines until the latter would exit a certain area. Then, producing the "croaking" sound for the last time, the objects would disappear. There had never been any confrontation with the objects in the long years of their interaction, yet the Soviet commanders and submarine crews were tense and under stress when the *kvakeri* accompanied their vessels.

Technology Made in America

Were the *kvakeri* "made in the USA"? America was the chief suspect as the origin of the *kvakeri* because the Soviet Navy surmised that its vessels were encountering an advanced US submarine-tracking technology.

Rear Admiral Vladlen Naumov believes that the *kvakeri* were US Navy sonic underwater buoys. Naumov points to SOSUS, an acronym for Sound Surveillance System: a chain of underwater listening posts across the North Atlantic Ocean near Greenland, Iceland and the UK. It was operated by the US Navy to track Soviet submarines in the Atlantic (and other oceans). Naumov has studied the experience of Soviet nuclear submarines armed with ballistic missiles designed to strike at strategic military-industrial targets of a potential adversary.

In September 1975, as a Captain 1st Rank (Military Unit 63900), Naumov was given command of the K-182 submarine cruiser. (A Delta II-class Project 667BD submarine, the K-182 was launched in January 1975 and commissioned on 30 September 1975. Project 667BD submarine cruisers had been actively utilised in the Soviet and, later, Russian navies from 6 February 1973 through to 24 April 1996.)

Naumov was able to hear the *kvakeri* during his missions, and he claims that he established a procedure to evade the sonic underwater buoys. According to Naumov, during its service history the K-182 was approached by the *kvakeri* 72 times and was able to cut contact with them 72 times. Consequently there was great interest from the Soviet High Command, which paid close attention to the submarine. Naumov's statements (in Russian) can be found at <http://tinyurl.com/3attxmu>.

Naumov's opinion is shared by an anonymous Soviet submariner, who expressed his opinion in one of the Russian forums dedicated to the *kvakeri* phenomenon. This person wrote that on a number of occasions he heard sounds emitted by *kvakeri* through the sound channel of the Soviet MGK-300 *Rubin* submarine towed-array sonar. He recorded the sounds and analysed them during the years he served aboard the submarines of the 3rd Division. This was in the mid-1970s, when the *kvakeri* phenomenon was in its heyday. At the beginning of the 1980s, he personally observed the phenomenon and became convinced that it was actually caused by an aerial buoy, dropped from US Navy PS or PM aircraft. He heard the familiar *kvakeri* sounds through the sonar

At the beginning of the 1980s, he observed the phenomenon and became convinced that it was actually caused by an aerial buoy, dropped from US Navy PS or PM aircraft. He heard the familiar kvakeri sounds...

sound channel of a surface vessel. An aircraft would drop the buoy, and the Soviet seamen at once would hear the *kvakeri* sounds from precisely the direction where the buoy had "landed".

It is significant, added the writer, that the sonar operators of surface vessels had not been given instructions to study the *kvakeri*. Or, he added, the results of such study could have been so mundane and clear that only the submariners still carried romantic recollections about the *kvakeri* phenomenon. As for the naval intelligence service, it apparently still secretly spits at the *kvakeri* phenomenon and maybe curses it in its heart.

The writer also mentioned that the *kvakeri* sounds always reminded him of the typical dry knocking sound of wooden spoons, as made by spoon players in Russian folk music. All other sounds, he believes, are "from another opera"; that is, of another origin. As for the *kvakeri* conduct, according to him it can be completely understood if we are to recall that the buoys contained water-filled cell batteries; as such batteries discharged, the signals emitted became longer. His views (in Russian) are at <http://tinyurl.com/3no485o>.

Fornicating Lobsters and Other Hypotheses

Not everyone in the Soviet Navy shared Vladlen Naumov's conclusions. According to E. Ibragimov, a Soviet captain involved in the research, the *kvakeri* possessed amazing manoeuvrability. They could move at speeds reaching 150–200 knots (up to 370 kilometres per hour), remaining at nose angle in

relationship to a submarine.

Another former Soviet submariner, who calls himself Dima the Guru, recalled that the *kvakeri* were heard differently aboard submerged subs. One time he heard something like a purr, rushing about outside the submarine; the estimated speed of the object was close to 80 knots.

Sometimes he felt, but did not hear, a sound he describes as "sh-sh-shookhhh", as if somewhere close something huge had rushed by—something obviously that was not alive. "How could it live at such speed?" he asked. On occasions, "something" small would lurk around the sub.

Dima mentioned that the "guys" who had served aboard the strategic Soviet subs (*strategi* in Russian naval slang), as people who value their secretiveness,

gave some semi-mystical status to this phenomenon in their conversations. On the contrary, the "guys" from the multi-mission subs treated the *kvakeri* with rather cynical humour, saying that playful lobsters were fornicating. Sonar stations working in the direct listening mode registered sharp changes of bearing in relationship to the objects. In the active mode, they sighted objects up to hundreds of metres in size, but only briefly. Dima added that while "on the surface" he had never seen or heard anything about the *kvakeri*. He said he thinks that the experimental manned submarines we know today are not capable of matching the speed of the objects. His statements (in Russian) can be found at <http://tinyurl.com/3ms3rmz>.

According to Admiral Anatoly Alexandrovich Komaritsin, Chief of the Main Directorate of Navigation and Oceanography of the Ministry of Defence of the Russian Federation, the Soviets tried to locate and detect the *kvakeri* formations with their acoustic stations. Sometimes, after moving through an area of *kvakeri* activity, Soviet submarines would return to base, only for their crew to discover that their subs' rubber surfaces were covered with some biological mass. This mass would emit light for a long time, but under the sunlight the luminescence would eventually disappear.

A former Soviet submariner, who stated his name as Sergey Vasilyevich, wrote about his experience with the *kvakeri* in 1985, while serving aboard the K-433 Soviet nuclear submarine in the northern region of the Pacific Ocean. (The K-433 was a Project 667BDR Kalmar-class Delta III nuclear-powered ballistic missile submarine of the Soviet Navy and is presently, under the name *Svyatoy Georgiy Pobedonosets*, part of the modern Russian Navy.) At a depth of approximately 100 metres, after an hour of "croaking" by *kvakeri*, the submarine encountered and collided with something soft and viscous. The sound was similar to the one that raw meat makes when dropped on a cutting board, but the "piece of meat" was so huge that it forced the submarine cruiser (of 13,000-ton displacement while under water) to shudder and shake.

Sergey Vasilyevich also recalled the incident that took place in 1989 when he was serving aboard the submarine K-211 in the Sea of Japan. (The K-211 was also a Project 667BDR Kalmar-class Delta III nuclear-powered ballistic missile submarine; now, as part of the

Russian Navy, its name is *Petropavlovsk-Kamchatskiy*. The submarine joined the Soviet fleet in 1980 and, as of 2009, is active in the Russian Pacific Fleet.) At a depth of 100 metres, the Russian sonar operators discovered two underwater targets that caught up with and overtook the submarine cruiser. They moved at a speed of 50 knots, while the Soviet submarine moved at 10 knots. The submarine's commander joked: "Your glorious sonar operators, oh commander of radio engineering, discovered an underwater aeroplane!"

This information comes from an article (in Russian) written and posted by Sergey Vasilyevich at <http://tinyurl.com/3t2mp73>.

Another former Soviet submariner shared his views on a website forum that discussed the *kvakeri* phenomenon:

"You cannot even imagine what took place in the Main Staff of the Soviet Navy during *perestroika* and fraternisation when the issue of the *kvakeri* was discussed with NATO. Realistically, NATO thought the *kvakeri* were our weapons, while we thought they were NATO's. It appears they were someone else's. The point is, neither could we build things at that level (that is why we thought about geniuses from NATO), nor could NATO (that is why they thought, 'What in damnation did the Soviets invent?')."

This information can be found at <http://tinyurl.com/4ydduzc>.

A Natural Property of Water

The Russian newspaper *Argumenty I fakty* published an article about *kvakeri* in its 9 June 2010 issue. The author, Yuliya

Garmatina, mentioned that eyewitnesses referred to *kvakeri* as "ghosts of the ocean".

Many Soviet submarines encountered such ghosts. It seemed to the submariners that the *kvakeri* that emitted croaking sounds wanted to ram their vessel and then disappear, as if to dissolve. Sometimes "it", as Garmatina was told, would glow, creating shapes in the water.

Garmatina also presented the views of a prominent Russian scientist on the origin of *kvakeri*. This scientist, Aleksandr Smirnov, from the Moscow State Institute of Radio Mechanics, Electronics and Automation (*Moskovskiy Gosuderastvenniy Institut Radiotekhniki, Elektroniki I Avtomatiki*), is an expert on the properties of water. He considers *kvakeri* to be a natural water phenomenon.

"You cannot even imagine what took place in the Main Staff of the Soviet Navy during *perestroika* and fraternisation when the issue of the *kvakeri* was discussed with NATO."

Continued on page 82



Lose 6 - 8 kgs in 6 weeks
fatlossAustralia.com.au

**Fat Loss
 and
 Rejuvenation Programs**

As read about in Dr. Sellman's Nexus article, "An Effective Solution To The Obesity Epidemic". Dr. Sellman's fatloss programs are now available in Australia exclusively through <https://fatlossaustralia.com.au>

For more information visit:
<https://fatlossaustralia.com.au>



TC energy design
 harmonic resonance in glass

Enjoy the difference that structured water can make to your life

BEFORE



AFTER



by restoring your water's integrity with handblown, harmonic glassware





Imported by NTP Health Products 1800 22 55 00
www.tcenergydesign.com.au

TC Energy Design products are masterpieces of form and harmony, beautiful mouth-blown glassware uniquely shaped to revitalise and restructure water.

Created from musical compositions that are converted into spatial dimensions and formed into balanced, harmonic glassware, the shape and form of the glassware generates an energising resonance pattern that restores water with subtle waves of harmonic sound.

The special design of TC products revitalises water, reminding it of its origins and restoring the integrity of its structure within **3 minutes.**

Discover the astounding energetic effect of TC Energy carafes, hand blown glassware and plates and enjoy all the benefits of drinking energized, structured water.

Social Threefolding presents New Approches for Our Economy

Financial Terrorism & Surviving The Financial Meltdown

An evening with Ian Crane

International lecturer in Deep Geopolitics

Ian R Crane - author, lecturer and documentary producer presents an alternative view of the global financial crisis.

Former oil industry executive Mr Crane has become one of the leading authorities in deep geopolitics, where geographic, economic, social, political and spiritual issues conjoin.

Over the past 18 months, Mr Crane has been sharing his unique insights into the globalist master plan with packed audiences across the UK and Ireland, examining why Iceland and Ireland were the guinea pigs for 'a forthcoming massive financial swindle, orchestrated by global financiers'. He presents evidence in support of his assertion that the current global economic meltdown has been carefully fashioned to bring about the financial bankruptcy of sovereign nations.

The politicians of the Australia also have difficult questions to answer, Mr Crane concluded: 'If Australia's politicians succeed in their apparent quest to bury the country in a mounting sea of debt, while pioneering the introduction of Carbon Taxes on behalf of the World Trade Organization and all the while reducing public services to minimalist levels, future generations will be condemned to lives of economic slavery.' www.iancrane.co.uk



Friday Oct 28th, 2011 at 6-10pm
Hannaford Main Hall, 608 Darling st, Rozelle

Ian continues to cover these issues Sat 29 and Sunday 30th in conjunction with other international speakers at a 2DAY INTENSIVE CONFERENCE "Building a Creative ECONOMY" at Balmain Town Hall

Cost :\$25 Concession \$15. Tickets: www.buildingacreativeeconomy.com or call 0416 359 638 or email info@buildingacreativeeconomy.com

ONE OF THE UK'S BEST ALTERNATIVE RESEARCHERS

THE GLOBAL FINANCIAL CRISIS, BIG PHARMA, GM FOODS, CODEX ALIMENTARIUS, PEAK OIL MYTH, CARBON TRADING SCAM AND THE 2012 AGENDA

IAN R CRANE

PRESENTS



MELBOURNE

5-11-11

TICKETS: WWW.HIDDENAGENDA2012.COM

The Hidden Agenda 2012

Surviving the final meltdown presented by IAN R CRANE

- Global financial crisis
- Carbon Trading Scam
- Hijacked Green Agenda
- Big Pharma
- Codex Alimentarius
- Bio tech
- GM foods
- Peak Oil Myth
- Global governance
- The Fracking Nightmare

Gold Coast Event
Gold Coast Arts Centre
6th November 10:30am - 6:00pm

Brisbane Event
Bardon Conference Centre
9th November 6:30pm - 9:30pm

www.thehiddenagenda2012.com

An Intense Forum on New Approches for Our Economy

Building a Creative Economy

OUR CURRENT ECONOMIC PROCESSES ARE DESTRUCTIVE OF THE ENVIRONMENT, OF OUR HEALTH, OF OUR CULTURE OF OUR EDUCATION, OF OUR ECONOMIC WELFARE.

THERE ARE OTHER CREATIVE SOLUTIONS AND THEY ARE POSSIBLE.

Intensive Weekend Forum with International speakers, Panel discussions, Workshops & Screenings



International speakers: Ian Crane - Geopolitics www.iancrane.co.uk
Terry Boardman - Social Threefolding www.monju.pwp.blueyonder.co.uk
Margrit Kennedy - Complimentary Currencies www.margritkennedy.de
National speakers: Bill Mitchell, Al Morris and more...
Screenings: 'Economics of Happiness' and 'Cultural Creatives'

October 29th & 30th, 2011
Balmain Town Hall
Sat & Sun start 9.15am

For Tickets go to www.buildingacreativeeconomy.com or call 0416 359 638 or email info@buildingacreativeeconomy.com

*Early Bird (until 15 sept) 2 days \$120, 1 day \$75. Reg. Price 2 days \$145, 1 Day \$95. Concession available.

CROP CIRCLES 2011

Towards a New Era?

This season's crop formations took a slight step back from the geometric and aesthetic heights of recent years, but still managed to surprise and put crop-watchers into suspense as to what the much-heralded year 2012 may bring.

by Andy Thomas © August 2011

Email:
info@vitalsignspublishing.co.uk

Websites:
www.truthagenda.org
www.vitalsignspublishing.co.uk

Cycles of Time and Change

The end, apparently, is nigh, as so many people seem very keen to impress upon us. But the end of what, exactly? With mainstream coverage of (claimed) Rapture schedules, Japanese tsunamis, NASA warnings of dangerous increases in solar activity, Arab uprisings, widespread social unrest and global economic disasters looming, not to mention the hysteria in alternative realms around coming devastations from Comet Elenin and/or the long-lost planet Nibiru, assertions that fulfilment of the many oft-discussed prophecies for 2012 might finally be kicking off have begun to gather credence.

It hardly seems possible that 2012 is now almost upon us. For years it seemed like some far-off and wistful fairytale future; but now, here we are and the unsettling developments do indeed seem to be accelerating. For some, "2012" is about an evolutionary leap of social consciousness rather than a specific event, but many others are awaiting a direct shift, be it cosmological, spiritual or geophysical—one that will help dislodge the accumulated human mistakes of the past and force positive, if temporarily disturbing, change.

It is an often overlooked fact, though, that for numerous people one of the key introductions to the 2012 phenomenon has been the crop circle mystery. As far back as 1997, formations started to appear in the fields that directly referenced the ancient 5,125-year time cycle of the Maya and other ancient cultures, long before the subject went mainstream. Indeed, it took a huge (if controversial) wheel of Mayan-like symbols near Silbury Hill, Wiltshire, on 2–3 August 2004 to take 2012 into the British tabloid newspapers for the first time, under the headline "The Doomsday Crop Circle".

Other designs, such as the remarkable diagram of our solar system as it will be on the crucial date of 21 December 2012 (the changeover point of the time cycle), which appeared near Avebury Manor, Wiltshire, on 15 July 2008, restated the importance of the connection (and with only what was presumed to be Pluto—or was it Nibiru?—placed differently to where astronomy would expect it to be).

Therefore, through two decades of extraordinary crop glyphs from their first real explosion of complexity in 1990, a feeling has grown that one of their primary purposes may always have been to build up those paying attention to them to be ready for a time of huge change—one due to occur about now. This is felt strongly, even by some convinced that many or all of the formations have been expressions of human divination rather than anything beyond this world. However, what this has also meant is that an ephemeral quality has slowly been woven into the expectations surrounding the phenomenon—a lurking fear that all this beauty and complex symbolism might suddenly be whisked away once the time that they are heralding arrives. For some, the crop formations of 2011, especially in their early weeks, seemed to suggest that the first step towards this stage might have been reached at last.



Innage, near Chepstow, Gwent, Wales. Reported 22 April.
Image: Olivier Morel © 2011, <http://wccsg.com>



Silbury Hill, near Avebury, Wiltshire. Reported 29 April.
Image: Lucy Pringle © 2011, www.lucypringle.co.uk

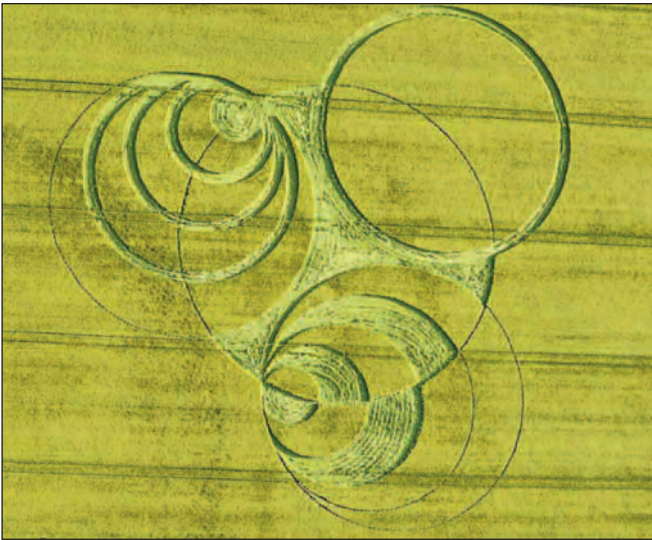

Hackpen Hill, near Wroughton, Wiltshire. Reported 30 May.
Image: Olivier Morel © 2011, <http://wccsg.com>

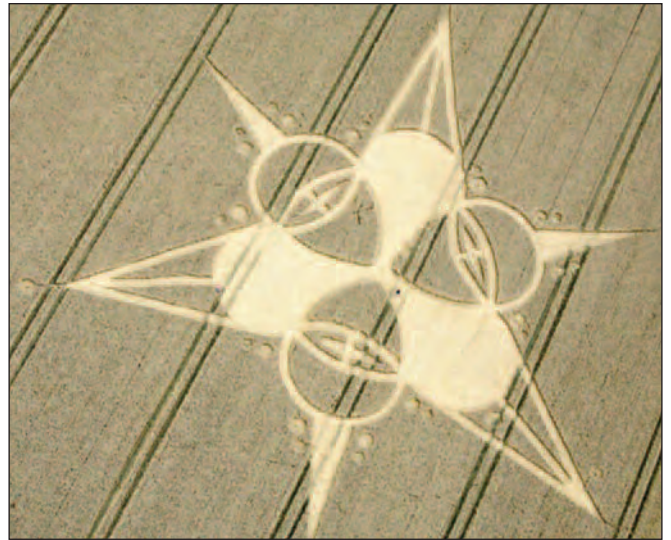

Bridge Inn, near Bishops Cannings, Wilts. Reported 4 August.
Image: www.cropcircleconnector.com

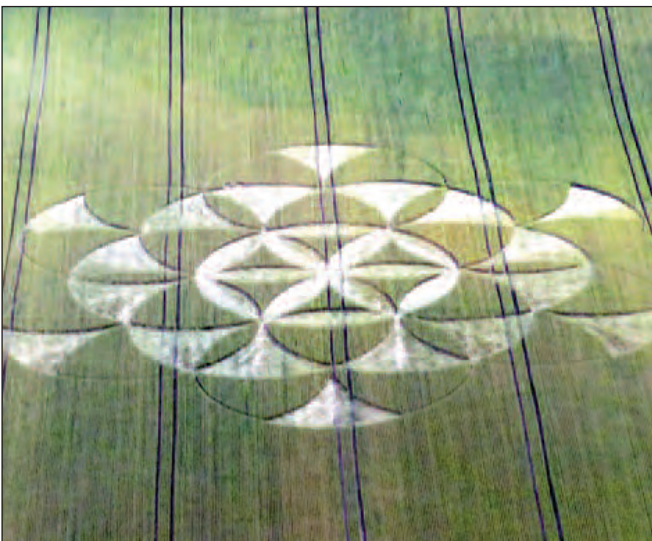

Walmsgate, near Louth, Lincolnshire. Reported 3 July.
Image: www.cropcircleconnector.com

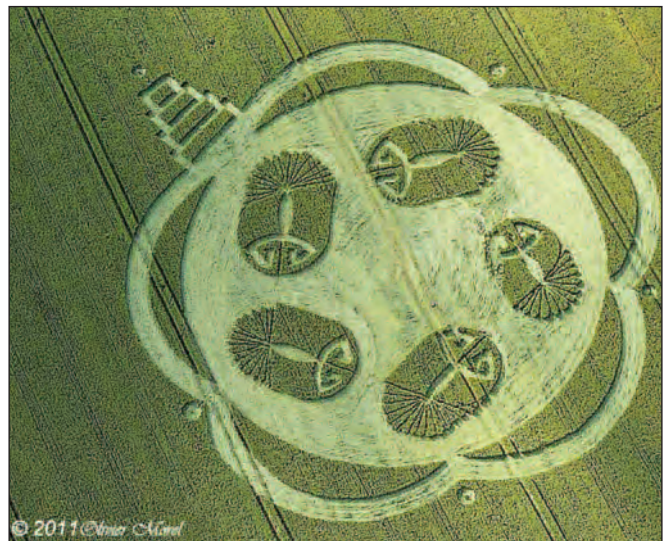

Honeystreet, near Alton Barnes, Wiltshire. Reported 4 July.
Image: Olivier Morel © 2011, <http://wccsg.com>

Not for the first time, events actually began outside of England, the core heartland for the majority of complex symbols. It was Krasakan, near Yogyakarta, Java, Indonesia, that saw the earliest activity of all, with a complex mandala being discovered in a rice paddy on 23 January, the first of three formations reported there that month. This was followed by a simple circle at Tlapanaloya Tequiquiac, Mexico, on 20 March.

The UK Season in Perspective

The UK had its first event—albeit with a slightly shaky-looking mandala in rapeseed (canola)—on 22 April (encouragingly earlier than 2010's May start) at Innage, near Chepstow in Gwent, Wales, a rare location for crop circles. Just two more would make it into April, the best of these being a swirled six-fold floral design, though again a little rough, in rapeseed at Silbury Hill, Wiltshire, England, on 29 April. By the end of May, another eight designs had appeared, of varying interest, but at this stage voices started to be raised about the perceived lesser quality of the year's designs, with perhaps only the optical trickery of the nested crescents at Hackpen Hill, Wiltshire, on 30 May, coming close to approximating the geometric and aesthetic heights of the phenomenon at its best.

A general disappointment with the season thus far allowed the ever-louder voices of a new breed of proactive sceptics—*cum*-claimed-circlemakers to begin a campaign of Internet haranguing that would persist throughout the summer, targeting known researchers one by one with hostile critiques of their beliefs and techniques in threatening tones. An intimation was made by the attackers that they, the cream of the supposed human circlemakers, were on a go-slow this year. Yet this revealed a paradox. A claim regularly heard from the neo-sceptics is that they "know everyone that makes the circles"—but their comments in the same breath in the early summer, pouring scorn on the lacklustre abilities of their apparent new rivals, made it clear that they do not know, in fact, who or what is responsible for all of the designs.

Unfortunately, the 14 UK formations of June, including cartoon snakes and a number of rather wobbly-looking efforts, failed to provide comfort to those awaiting the return of the masterpieces usually seen by this time in previous years, hence the growing speculation that maybe we were seeing a running-down of the phenomenon from its glory years, its main impetus perhaps spent as the goal of 2012 fast approached. Had the "real" phenomenon really deserted, leaving the fields to amateurs? Others, however, were less sure, pointing to more accomplished works such as the mandala of crescents at Worlaby in Lincolnshire on 18 June and the exotic cross that appeared at Lockeridge, Wiltshire, on 21 June, holding their breath for sequels that would prove the doubters wrong.

Finally, in July, a general rise in quality emerged, if

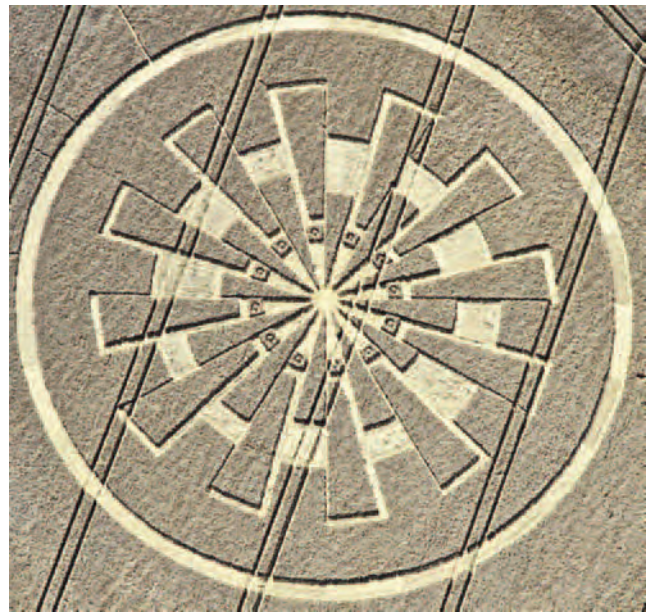

Temple Farm, near Rockley, Wiltshire. Reported 7 August.
Image: www.cropcircleconnector.com

restrained in number compared to many seasons. Although some of the patterns still seemed a little subdued, Lincolnshire again bucked the trend with a neat and striking "flower of life"—style formation near Louth on 3 July, while Wiltshire produced optical-effect designs at Milk Hill on 6 July (with an addition made on 9 July) and near Stonehenge on 13 July.

This same day (and county) produced two hypnotic, tight double-spirals at the classic site of Windmill Hill, near Avebury Trusloe, and at Mere.

It was the later part of July, however, that saw the full-on return of the type of formations that people have, perhaps rather presumptuously, come to expect. Amongst other graphic adventures, complex Wiltshire mandalas of seemingly increasing beauty and technical craft began to arrive: at Overton Down, near Avebury, on 18 July; at East Kennett on 22 July; at Etchilhampton on 25 July (with intriguing, notched "basket weave" edges); and at Windmill Hill once more on 26 July.

The return of the snake motif at the end of the month,



Windmill Hill, near Avebury Trusloe, Wilts. Reported 13 July.
Image: www.cropcircleconnector.com

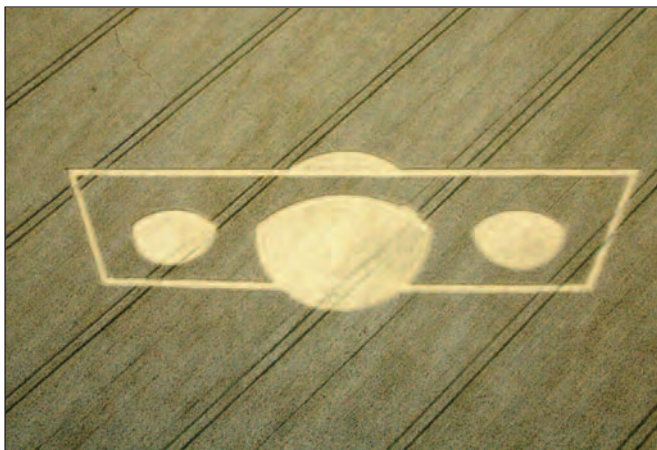

Furze Knoll, Bishop Cannings, Wiltshire. Reported 6 August.
Image: www.cropcircleconnector.com



Windmill Hill, near Avebury, Wiltshire. Reported 26 July.
Image: www.cropcircleconnector.com



Jubilee Plantation, near Cherhill, Wilts. Reported 15 August.
Image: www.cropcircleconnector.com

at West Woodhay Down, near Inkpen, Wiltshire, on 29 July, if in a far more ambitious and much larger developmental stage, either sounded an ominous note from the neo-sceptics or was a piqued response of some higher level of the phenomenon to the cartoon versions of preceding weeks (curiously, strange lights were witnessed hovering over this formation in the days after its appearance).

A number of other glyphs also gave ambiguous messages, almost designed to make a point of sowing confusion amongst observers. A humorous motif of a pipe-smoking "Grey" ET below the Wiltshire white horse carving at Calne on 27 July, for instance, at face value smacked of obvious human authorship, yet from a distance it looked well-made (a more straightforward emblem of an ET face had arrived earlier at Hinton Parva on 20 July). Another formation, of strange scorpion-like motifs at Honeystreet, Wiltshire, on 4 July, appeared to be left rather roughly half-finished, just to make a point (being "completed" the next night). This, of course, played into the claims of the aforementioned haranguers, who state that all of the complex designs are man-made and that nothing is beyond their capability—despite their continued failure to show this in open demonstrations.

There are few today who would state that there are no man-made formations. It has long been clear that the human element is now an embedded component of the crop circle phenomenon, although in what proportion has never been established with actual evidence. Until recently, the claimed circle-makers seemed to have been happy just to create mystery and leave people to their own journeys. Now, however, the stated intention is to stake their claim to full authorship and publicly tackle anyone who believes otherwise. Yet their strange bitterness at the unavoidable reality that others are commercially capitalising on what, by their very nature, are public-domain symbols creates a needlessly dark atmosphere, raising more questions than are answered. After all, why shouldn't the faithful continue to believe that at least *some* of the thousands upon thousands of crop glyphs we have seen over the years may come from "somewhere else"? Facts stand for themselves. If undeniable evidence exists that every circle ever made has been made by humans, then it should be presented clearly and definitively so that it can be dealt with and people can make up their own minds. Despite many opportunities, any such evidence remains undisclosed and the fascination with crop circles will therefore continue as long as the phenomenon does. How long that will be is, of course, where this article started.

August produced another nine formations in the UK. Although still patchy compared to some seasons, the month generated a number of eye-catching patterns, such as another in the optical-trick genre at Bishops Cannings, Wiltshire, on 6 August, seeming to show three spheres sunk into a flat rectangular plate, and a complex windmill-like design at Rockley, Wiltshire, on 7 August.

The final major UK formation at the time of writing arrived at Cherhill, Wiltshire, on 15 August (although a small glyph appeared near Alnwick, Northumberland, on 28 August, and the last few seasons have generally seen some late additions in early-autumn maize fields). This provided a mathematical "closing statement" comprising a grid of thin, overlapping star geometries within a ring of textured basket-weave crop at the centre of swirled arcs, with a stylised elephant-like glyph nearby, very similar to previous versions which have appeared in the same area of fields in years past. By this, the phenomenon seemed to be making a conscious link to its own heritage.

In total, the UK did manage to produce 60 formations this year, which is no disgrace, even if the overall quality was generally agreed to be down, for all the exceptions.

Formations Abroad

Meanwhile, the rest of the world produced its usual remaining proportion of the results, with 46 designs scattered across countries as diverse as Indonesia and Mexico (as we have seen), Russia, Slovakia, Belgium and the USA, all with a few formations each. The Czech Republic also reactivated (as it does every few years) with seven attractive patterns, while The Netherlands reached 10, although most of these were largely small and rough, often in wild grassland.

Of the two countries that usually produce the nearest equivalents to the generally more elaborate UK crop glyphs, Germany disappointed this season with just three

designs, albeit well-made ones, but it was Italy that stepped up to the challenge again with 12 events, at least two of which matched or surpassed the contemporary English efforts. An elaborate wheel design at Braccagni, Grosseto, Tuscany, on 4 June would not have looked out of place in the UK, but the astonishing and complex seven-pointed star at Poirino on 20 June, complete with possible astronomical references, took things to a different level and appeared to be a sequel to another similarly stunning formation there almost exactly a year before.

Expectations for the Future

The top formations of 2011, then, showed that the circle enigma is certainly not done yet. But there was a sense, nonetheless, of a subtle shift away from the guaranteed excellence that we have all become used to, as if we might be entering the first stages of something preparing to wean us off our addiction to these endlessly stimulating shapes with all their attendant mysteries and fascinations. Of course, it may simply be the case that another year will disprove such speculation, and that perhaps this season has merely been a tantalising lull, with the most extraordinary designs ever seen just waiting in the wings for next time.

However, what if the imminence of 2012-and-beyond does start to take away from us something that has warmed so many hearts these past two decades? And if large cosmic events or Earth-shattering world



West Woodhay Down, near Inkpen, Wiltshire. Reported 29 July.
Image: www.cropcircleconnector.com

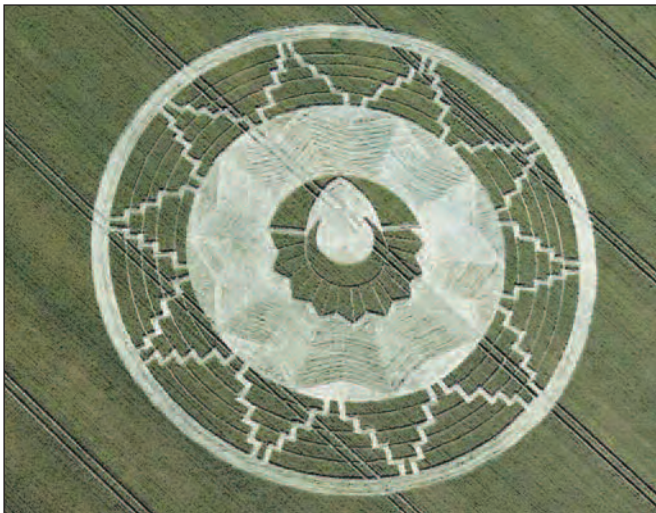

East Kennett, near Avebury, Wiltshire. Reported 22 July.
Image: www.cropcircleconnector.com

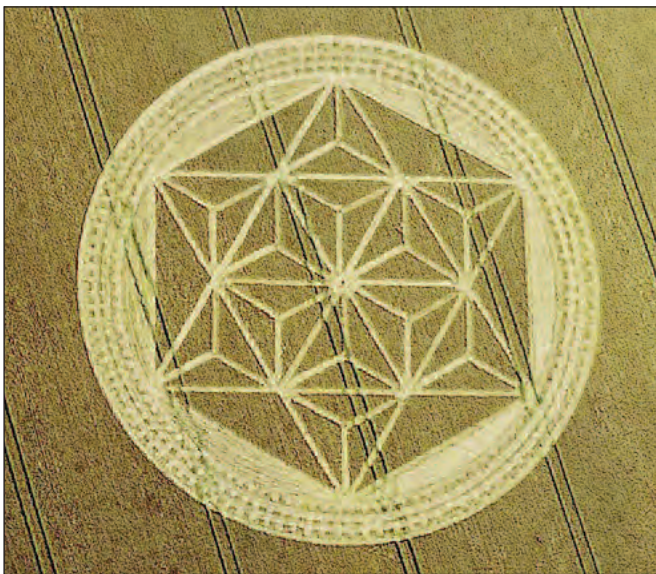

Etchilhampton, near Devizes, Wiltshire. Reported 25 July.
Image: www.cropcircleconnector.com



Overton Down, near Avebury, Wiltshire. Reported 18 July.
Image: www.cropcircleconnector.com

developments do start to activate, will anyone even have the time to notice them gone? Will the circles become just a quaint puzzle of the past, or will they give way to something even more spectacular and mystifying to take their place? As ever, only time will tell.

Next year, with the eyes of the world on England in high summer (the peak of a usual circle season) courtesy of the Olympics, it will be interesting to see if the phenomenon has a last special trick up its sleeve before embarking on whatever the next era may bring...

But the crop circles won't be entirely forgotten, either way. The UK media were largely quiet on them in 2011, with just a few press articles here and there, but there was a brief flurry of interest around an article by Richard Taylor in the August edition of *Physics World* which declared that people are probably now making the formations with microwave-emitting magnetrons—which at least was something beyond the usual media obsession with planks and ropes.

However, a sharp reminder that the circles have now indelibly woven their way into the fabric of *everyone's* lives was given when that most massive of past and current British television successes—*Doctor Who*—gave its first-ever nod to the circle phenomenon in the opening episode of the new series in late August.

For some children, the sight of the time-and-space-travelling TARDIS sitting in the middle of a crop circle (ironically, the subject of a bestselling joke postcard for some years) might be the very thing that sets a whole new generation of cropwatchers on an exploratory journey all of their own, as imaginations and belief-envelopes are stretched and stimulated, as they have been so many times before.

Indeed, it is those journeys that can never be taken away, no matter where the circles or the thinking around them goes from here. There remains, therefore, every reason to celebrate their continued existence, to this day at least. ∞

About the Author:

Andy Thomas is one of the world's leading mysteries researchers and is the author of the acclaimed book *The Truth Agenda: Making Sense of Unexplained Mysteries, Global Cover-Ups and Prophecies For Our Times* (Vital Signs Publishing, 2009–2011), which was republished in a brand new edition this year and has been widely described as one of the best available overviews of its subjects. Andy is also author of five books on the crop circle phenomenon, including *Vital Signs*, considered by many to be the definitive guide. He widely lectures around Britain and the world and has often been a guest on mainstream TV and radio programs.

For more information about Andy Thomas and his work, visit his websites: <http://www.truthagenda.org>; <http://www.vitalsignspublishing.co.uk>; and <http://www.glastonbury-symposium.co.uk>. Andy can be contacted by email at info@vitalsignspublishing.co.uk.



THE UFO INCIDENT AT SHAG HARBOUR, NOVA SCOTIA

It was a little after 11.00 pm on the night of 4 October 1967 when an unknown object with four bright lights flashing in sequence and estimated at 60 feet in diameter was observed hovering over the ocean near the small fishing village of Shag Harbour, Nova Scotia, Canada.

Several residents of the village first noticed a rather strange grouping of orange lights. Several eyewitness accounts indicate that there were four orange lights that evening. Five of these witnesses included a group of teenagers who watched these lights flash in sequence for several minutes and then suddenly and rapidly dive in a sharp 45-degree angle toward the water's surface.

To the amazement of the teens and other eyewitnesses, on hitting the water's surface the lights did not immediately disappear beneath the gentle swells but seemed to float on the surface, approximately half a mile from the shore.

The initial panicked reaction of the observers was that they were

witnessing the emergency ditching or crash of an aircraft. The first report phoned into the RCMP (Royal Canadian Mounted Police) in Barrington came from a young fisherman who told them that an airliner had gone into the bay.

The first reaction by the police dispatcher was that the young man had been drinking; however, after an immediate rash of 10 additional calls reporting the incident, the police quickly re-contacted the young fisherman for location details.

Within the same time period, however, Constable Ron Pound of the RCMP was on patrol on Highway 3, heading toward Shag Harbour, and had been observing the strange lights as he increased his speed in the direction of the incident. Constable Pound's report stated that he believed the four lights were coming from a single aircraft that he estimated to be about 60 feet long.

As Constable Pound reached the shoreline, he was joined by two other officers, Police Corporal Victor Werbieki and Constable Ron O'Brien. Additionally, several of the fishing

village's residents stood on the shore, watching and questioning what to do next. According to Constable Pound and the other officers, the orange lights slowly changed to yellow and the object appeared to move slowly across the surface of the water, leaving a yellowish foam in its wake.

By this time, no fewer than 30 witnesses from various vantage points watched as the object slowly drifted further from shore. All would later describe the object as about 60 feet long, 10 or so feet high and dome shaped.

After about five minutes, the object started to sink beneath the icy North Atlantic waves.

A few of the eyewitnesses reported hearing a "whooshing" noise.

While the RCMP had already been in communication with the Canadian Coast Guard and cutter 101 was on the way, two of the RCMP officers and a few local fisherman hurriedly launched their boats to speed to the rescue of any survivors.

When their small boats and cutter 101 reached the location, the lights

were no longer visible but they found themselves sailing through a thick yellow foam which indicated that something had submerged. (The fishermen reported that the foam was not sea foam, and it looked like nothing they had ever seen. In fact, most were unnerved by the fact that they had to sail through it to look for survivors.)

After several hours of searching, they found nothing and the search was called off at approximately 3.00 am.

Both NORAD and the Rescue Coordination Centre in Halifax had been contacted by the RCMP, and there had been no reports that evening of missing aircraft, either civilian or military.

On 5 October (the following day), the Rescue Coordination Centre filed a report with the Canadian Forces Headquarters in Ottawa. This report stated that something had crashed into the water in Shag Harbour, but the object was of "unknown origin".

The Canadian Forces Headquarters dispatched the HMCS *Granby* to the Shag Harbour crash site, and, using advanced detection equipment and specially trained divers from the Navy

and the RCMP, the Canadian military systematically searched the sea floor for several days and found nothing.

Here in 1967, the mystery ended with no physical evidence ever recovered and no additional leads.

Military Tracking of UFOs

For a few years, the story kicked around in the local papers. From

As the Navy waited and planned, the detection equipment picked up another object moving in, and...it joined the first object on the ocean floor.

time to time, various theories and intriguing rumours emerged about Russian spacecraft or Russian submarines and an American follow-up investigation. Then the story simply faded into obscurity.

That is, until 1993 when the Shag Harbour incident once again was brought to the attention of the public. This was due to the

dedicated investigative efforts of two men who are investigators with MUFON [Mutual UFO Network]. Chris Styles, assisted by Doug Ledger, using public records such as newspaper clippings and police reports, were able to track down and interview many of the eyewitnesses and individuals involved in the Shag Harbour sighting, the rescue attempt

and the subsequent investigation. Through their work, some extremely compelling clues and amazing new insights were uncovered.

In interviews with divers and crew members from the HMCS *Granby*, they discovered some startling information. The object that dived into the waters off Shag Harbour had been tracked, and it had actually travelled underwater for a distance of about 25 miles to a place called Government Point.

In the 1960s, the US had maintained a small but technically advanced military base at Government Point, managing a Magnetic Anomaly Detection system (MAD grid) for the purpose of detecting and tracking submarines in the North Atlantic.

The US military had most definitely detected the object on its sensitive tracking equipment. Naval vessels were dispatched and positioned over the unidentified object where it had stopped. After three days of no movement, and not knowing exactly what it was, the military was planning to initiate an investigative salvage operation.

As the Navy waited and planned, the detection equipment picked up another object moving in, and, to the amazement of all those involved, it joined the first object on the ocean floor. The speculation at the time was that the second UFO (officially now an "underwater flying object"?) was there to render aid to the first object.



Not fully comprehending what it was dealing with, the Navy decided it was best to stand by and observe. For nearly a week, the Navy vessels held their position over the UFOs.

The detection base, however, located a Russian submarine that had entered Canadian waters to the north, so several of the vessels had to be pulled off target to sail north to investigate. Under the cover of this new activity on the surface, both UFOs made their move, accelerating underwater toward the Gulf of Maine.

The remaining Navy vessels pursued them toward the United States, but the objects continued to distance themselves from their trackers.

To the astonishment of the pursuers, both of the objects broke through the surface and shot skyward to vanish within seconds.

According to the researchers, while these observations were well corroborated by many credible eyewitnesses, these accounts were given "off the record" by military, ex-military and civilian personnel who fear harassment, ridicule or loss of pension. So, as the saying goes, "only the names have been changed to protect the innocent".

Clearly, a series of extraordinary and still unexplained UFO encounters, involving the navies of two countries and NORAD, occurred at Shag Harbour on 4 October 1967 and in the following week in the deep waters off the coast of Maine.

– MUFON Canada

SHAG HARBOUR UFOs

The evening of 4 October 1967 was rife with UFO reports from all over eastern Canada. One very strange event was reported by an Air Canada pilot and first officer.

There was a report of an object sighted by a Mountie and three game wardens (they were staked out in the

forest, trying to capture some deer-jackers) 30 miles north of Shag Harbour around the same time. The object was believed to be the same one that was reported in the fishing village. They were astute enough to take a compass bearing on the object, which proved to be on a direct heading for the fishing village.

To the astonishment of the pursuers, both of the objects broke through the surface and shot skyward to vanish within seconds.

A time-lapse photograph (using Ektachrome 64 slide film) was taken by a professional photographer of an object bearing in that direction. We have obtained a copy of the photo but cannot be sure that it was of the same object due to the distance from the sighting. The slide also shows star smears from the time lapse while

the object stays rock solid.

What began as an interesting story—the "trapping" of an object 80 to 100 feet down (while being serviced by another object) by seven naval vessels off Government Point, Shelburne (also the site of a submarine listening station and MAD grid)—has expanded to include the muting of military witnesses, most of whom have not been in the forces for 15 or 20 years, and local witnesses who offer evidence of this event while being questioned on another. Canadian Coast Guard documents have been tampered with or access to them has been refused.

– Don Ledger, co-author with Chris Styles of *Dark Object* (Dell Publishing, New York, 2001)

Postscript

In July 2009, an underwater survey was conducted near the location where the first craft was said to have entered the water. For coverage, see <http://tinyurl.com/3mmg5k3> and <http://tinyurl.com/3je4owr>.

(Source: <http://tinyurl.com/3j7lfrv>, 12 September 2011)



COMMAND SERGEANT MAJOR HAS PROOF OF UFOs

In September 1977, during the Joint Attack Weapons System (JAWS) test at Fort Benning, Georgia, the entire base witnessed a UFO invasion. As many as 1,300 troops were involved in the event. Most were left with severe psychological trauma and "missing time" experiences.

Command Sergeant Major James Norton, who is now stationed at Fort McClellan, Alabama, was a buck sergeant (E-5) when he witnessed an eerie encounter with UFOs and the military on 14 September 1977. He had been sent to the range a little before midnight, along with 1,200 to 1,300 troops, to perform live fire with their new weapons system. The Secretary of the Army at the time was actually at the range.

Norton remembers when they started the live fire: all of a sudden there were orbs in the night sky. Next, he saw lasers criss-crossing through the sky. The command of "Cease fire!" was then heard: there was something down range. Military helicopters appeared out of nowhere. Explosions were heard.

Orbs in the sky were changing into a variety of colours. A triangle-shaped UFO showed up. The soldiers around Norton were in shock.

After the incident, many soldiers became ill. Every soldier was briefed that if they were to disclose any information from this night, they would be court-martialled and sent to Leavenworth.

Orbs in the sky were changing into a variety of colours. A triangle-shaped UFO showed up.

Missing Time Experience

When Norton obtained his medical records, he found that his illness had been recorded as of unknown origin. His temperature had been 104°F (~40°C), and he'd spent two days in a steel tub filled with iced water to bring down his temperature.

Norton had had a memory lapse—or, as we know it in UFO lore, a missing time experience.



US Command Sergeant Major James Norton

He could not remember how he'd come to be on the range and later in the woods; there was much time disorientation. During an hypnosis session, he learned that he had been abducted and taken aboard a craft where medical experiments were conducted and samples were taken from his body.

Crash Debris Evidence

After the Fort Benning incident, two unmarked jets came in to collect crash site debris.

Norton, however, had already picked up a metallic piece, containing strange hieroglyphs, from the crash site. He found that it cannot be burned or cut by hacksaw; and if it's bent, it goes back to its original shape.

Norton has this metallic piece buried at his property. He is willing and ready to show this evidence to some credible ufologists and to the media. He claims that he has proof of UFOs being real, with this solid piece of evidence that he's held onto since the incident.

He says that the military helicopters that were shot down during the UFO encounter were never reported to the FAA. Furthermore, Norton claims that he was burned by a mysterious red substance during this incident.

He also describes experiments with biological and chemical substances going on at the Fort McClellan base. But something else is going on: UFO activity. It seems that the US military is test-flying UFOs over the base.

Norton has night-vision footage of UFOs of all colours taken on the base. He has footage of a UFO going from horizon to horizon in a mere two seconds. He has video footage of a triangle-shaped UFO hovering over the base, emitting no sound. He has all of this footage for any credible ufologist to review. ∞

(Source: Edited from *UFO-Blogger.com*, 31 March 2011, <http://tinyurl.com/6zofbdk>)

OCEAN ORMUS

LIFE FORCE ESSENCE



250ml \$60
1 Ltr \$180

I suffer from 3 disc lesions in my back and damaged tendons in my leg. Since taking your Ormus, my pain levels have been reduced significantly and I feel less stiffness in my back. Thank you.
Mikey Vic

I wanted to let you know that the Ormus is working really well for me so far. I have an auto-immune disease which makes me really tired and the Ormus is helping me be more energetic. Also I've had hip / pelvis pain from a car accident for the past 15 years and after 4 to 5

Ormus - a wonderful gift from Nature that can benefit all living beings in many ways.
Ocean Ormus is a quality Ormus, sourced from the pristine Great Southern Ocean waters near Albany Western Australia. The vibrant energy of this special location helps make Ocean Ormus especially potent, along with the informational imprinting it receives from our crystalline array. Try our **Garden Ormus** too, great for improving the size and quality of your plants and crops!

We also have our Ormus-based **Skin Care Creams** which are rejuvenating for your face and body and made with all natural ingredients. **Alpha M** cream is for men and **Femme Essential** is for women. Both in 120ml jars, \$50 each.

PERFORM Pain Ease Cream. This easily absorbed 100% Natural Pain Ease Cream is a multi-purpose cream that provides relief from aches, strains, muscle pain, cartilage pain, rheumatism, inflammation, swelling, back aches, body stiffness and bruising. 120ml jar for \$50.

Some feedback from a few of our customers.....

days of taking the Ormus, I've had no more pain. So everything is working out very well with the product. **Joanne WA**

Here is my testimonial after 9mths of using OCEAN ORMUS.

* Silver-white hair now dark-grey with some regrowth.

* Bent and arthritic finger now straight but with some swelling.

*Competitiveness, feelings of wellbeing, intuition & decisiveness are greatly enhanced.

* My back has no discs between vertebrae so I used to take glucosamine daily * I can now go four days without any tablets.

*Bad tinnitus - now not so loud - a god-send.

* My face aches from smiling. :-)

Mike WA

In just a few days I noticed my depression is gone, more effective than St Johns Wort. Better mental sharpness, better sleep and more energy.

Don NSW

Phone : 040 793 4090 Email : oceanormus@westnet.com.au

BEYOND BELIEF: The Ultimate Mindpower Instructional Manual

Author - James F. Coyle

- Influence others in a win-win situation
- Influence Slot Machines or Dice fall
- Produce specific dreams to solve problems
- Use same dream technique for medical problems
- Determine luck cycle for advance financial windfalls
- Enhance your intuition for unbelievable lifestyle
- Use Remote Viewing for future advantage
- Learn mental pendulum for secret winning situations
- Learn techniques for automatic luck attraction
- Plus many other spectacular secret mind techniques

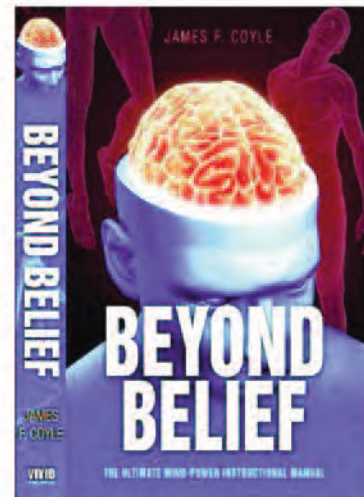

FULL DETAILS+ORDER FORM - www.mindtech.com.vu

Price \$39 plus \$11 post and handling. TOTAL A\$50. Australians add \$5 GST (TOTAL \$55)

Mail orders- NEXUS MAGAZINE PO Box 30 Mapleton QLD. 4560 AUSTRALIA

Tel: 07 5442 9280 Fax: 07 5442 9381

ON SALE NOW - OUTSTANDING TITLES BY TONY BUSHBY

LIMITED STOCK - MAXIMUM OF 5 BOOKS PER ORDER

- The Secret in the Bible
~~\$37.95~~ NOW **\$8**
- The Bible Fraud
~~\$34.95~~ NOW **\$2**
- The Crucifixion of Truth
~~\$34.95~~ NOW **\$8**
- Life Beyond Death
~~\$21.95~~ NOW **\$5**

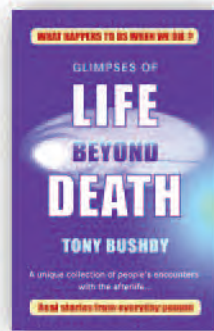
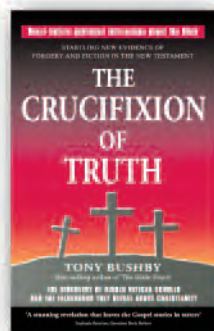
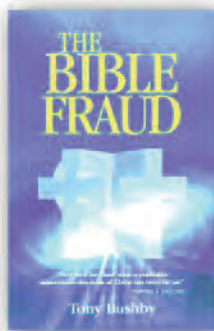
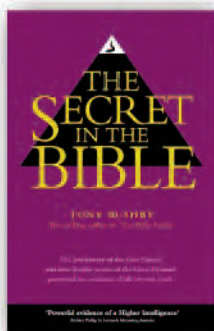

P&H - \$8 per book OR \$12 for 2 or more.

TO ORDER PHONE 1300 888 221 IN AUSTRALIA

and have your credit card details ready OR send Cheque or Money Order in AUD\$ to
JOSHUA BOOKS - PO BOX 1668, BUDDINA 4575 QLD. AUSTRALIA



Joshua Books
JoshuaBooks.com

NEW FROM MISTYMOON MOUNTAIN

www.mistymoonmountain.com

HOW TO FIND YOUR MISSING BIT

Gareth J. Owen

With a modicum of humour by our side, this incisive book travels through the absurdity of our society, questioning what we do to ourselves and the planet. As we go searching for our 'missing bit' and a way to turn this mess around, we travel from the Northern Beaches of Sydney to the streets of London and many average places in between.

On the way we encounter 'thin places', strangeness in the fields of Wiltshire, dead Mayans, allegorical aliens agendas, endemic poverty, empty oil wells, lousy food, French people, illusory money, fear, global icing and only one taxi on the Isle of Iona ...

WALK WITH ME

Nerida Oberg

A prominent Sydney psychotherapist and senior college lecturer, who for twenty years specialised in grief counseling, is suddenly faced with the death of her own twenty year old daughter, only to then find that her whole academic and professional career is thrown into doubt when she starts to receive messages from her daughter after her death. Join Nerida in a deeply moving and very personal account of the days surrounding the actual loss of her daughter through to the transformational power of the realisation that our concept of death is both limited and incomplete.

"I strongly encourage you read this book. "Laura Daniel, Editor The CAPA Quarterly



Mistymoon Mountain

Order from Nexus Magazine on + 61 (0)7 5442 9280
or at www.nexusmagazine.com



REVIEWS

BOOKS

Reviewed by Ruth Parnell

HORMONE HERESY

by Dr Sherrill Sellman, ND

Joshua Books, Queensland, Australia, 2011 (revised, updated edition)
ISBN 978-0-9870785-0-6 (348pp tpb)
Available: www.joshuabooks.com

Naturopathic doctor Sherrill Sellman has been writing about hormones and our health for two decades. This 2011 edition of her best-selling book *Hormone Heresy* (1996; see 4/02, 17/02) is a revised, updated version that includes new findings as well as material focusing on the hCG "hormone" in a weight loss protocol and on missing pieces in the weight loss puzzle (see 18/04).

There's a wealth of information here on how to achieve good hormonal health, how to combat disruptions from EMFs and dirty electricity, how to get younger as we age, and how to utilise food as medicine. There's coverage of the link between hormonal imbalance and disease, the benefits of natural progesterone in rebalancing, and the secret to creating sacred feminine power. Plus there's an updated list of educational and support resources.

Committed to helping women from

menstruation to menopause and beyond, Dr Sellman is a voice of reason, a font of knowledge and a sensitive educator who can guide women to personal empowerment.

DIRTY MEDICINE: The Handbook by Martin J. Walker

Slingshot Publications, London, 2011
ISBN 978-0-9564093-1-7 (325pp tpb)
Avail: www.slingshotpublications.com;
NEXUS UK Office, tel 01342 322854

It's been nearly 20 years since Martin Walker published *Dirty Medicine*, about big business and the assault on natural health care (see 2/19). Yet now, alternative and complementary medical treatments are under attack as never before—e.g., as seen in the Codex Alimentarius edicts on nutritional supplements that are soon to be enforced. Walker has produced this follow-up manual for those who want to know exactly whom they're up against—corporate scientists and lobbyists, "quackbusters", "health corporatists" in organisations and institutions linked to government, insurance industry scammers and more—and what to do about them.

Walker adds some touching personal stories that shed light on why he's gone down the alternative medicine path, although he does acknowledge that allopathic medicine

is essential in particular situations. But generally he is scathing of individuals, organisations and ad-hoc groups that serve as minions of corporate medical research. He also criticises "evidence-based medicine" which says "next to nothing about the reality of pharmaceutical-based research". He is outraged that alternative medicine practitioners and academics get nary a look-in when the Medicines and Healthcare products Regulatory Agency demands massive charges for licensing tried and tested preparations.

We have to deal with the deceit that corporate medical science employs and fight back to reclaim our health freedom, Walker urges. He provides plenty of resources and strategies to help us become better organised.

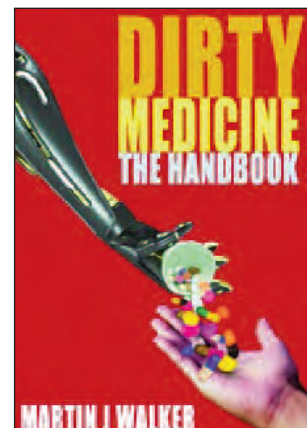

EMF Meter!

It's so easy to use! Take Unlimited EMF (Electro Magnetic Field) readings at home, office, school – anywhere!

- Made in USA, High Quality. Reliable, Accurate and Inexpensive.
- All Nexus customers will receive a free stress relief relaxation audio program www.destress.com.au.
- Great Value! EMF Meter only \$95

Order both products now from 0263355216 or online at

www.emfmeter.com.au

(Prices include GST & Delivery within Australia)



And Dog Dazer!

Electronic Dog Repellent!

Reduce the chance of dog attack!
Simply press and point the Dazer at the dog.

- ideal for joggers, walkers, postmen, cyclists, the elderly, meter readers, service engineers and sales people -- anyone worried about dogs.
- Does not harm the dog - or I would not offer it for sale!
- high frequency sound
- heard only by dogs
- latest ultrasonic device
- hand held
- lightweight
- compact, stylish.

At only \$98, the Dazer gives you peace of mind when you walk about!



REVIEWS



PULP MED: Why Doctors Will Give You Only Half-Truths

by **Petros Arguriou and Beldeu Singh**

O-Books, Hants., UK, 2011

ISBN 978-1-84694-699-8 (246pp tpb)

Available: www.o-books.com

Modern "populist" medicine doesn't answer fundamental questions about life, death, health and disease, yet it purports to have know-how and is determined to exert control in all these areas. It's fuelled by sickness and it thrives at our expense. This "pulp medicine" is full of anomalies. It doesn't have an underlying philosophy of true health. We need a new definition/measure of health encompassing the physical, emotional and mental-spiritual planes. This is the gist of this well-researched, well-referenced book by Greek alternative press columnist and occasional NEXUS contributor Petros Arguriou. It contains contributions from anthropologist Beldeu Singh, homeopathic medicine professor George Vithoukas, biologist Dr Mae-Wan Hoe and investigative health journalist Janine Roberts, all of these fitting seamlessly within the text.

Each chapter has sections that are preceded by the statement, "Why doctors will give you only half-truths about...". Among many items discussed are pharmaceutical drug

safety, the failed wars on cancer and illicit drugs, DNA, viruses and vaccines, and chemical and free-radical pollutants. Solid, disturbing facts are presented that show we're on the verge of a global dictatorship in health, medicine and psychiatry. Big Pharma's push to make natural medicine illegal is one case in point.

Arguriou and his collaborators give some profound suggestions and telling statistics on the way to re-humanising medicine and preventing abuses of power and trust. It's a strategy that encompasses science, the individual and society.

THE PSILOCYBIN SOLUTION

by **Simon G. Powell**

Park Street Press, VT, USA, 2011

ISBN 978-1-59477-405-8 (278pp tpb)

Available: www.ParkStPress.com;

www.deepbooks.co.uk

Expand your mind to consider that Psilocybin—the active ingredient of a sacred Mexican mushroom—can help in the care of terminally ill patients and in treating people with psychological disorders, as well as enhance the interface between consciousness and our greater reality.

London-based author Simon G. Powell has been his own case study into the effects of psilocybin and the psychedelic mushrooms available

legally in his homeland, but he's also delved into the history of sacred mushrooms in shamanic cultures and researched the growing body of scientific knowledge on some extraordinary fungi (see book extract in 18/05). Many of these fungi have "entheogenic" properties, in that they "generate the divine within".

It's as if these fungi, which grow wild on most of the Earth's land surface, beckon us to commune with them, Powell hints. And if we do have the chance, we'd do well to heed his advice on the "retuning" process. This communion offers a link with the intelligence of Nature. Opening the doors of perception and returning to entheogenic wisdom could ultimately create a more mystical, meaningful society.

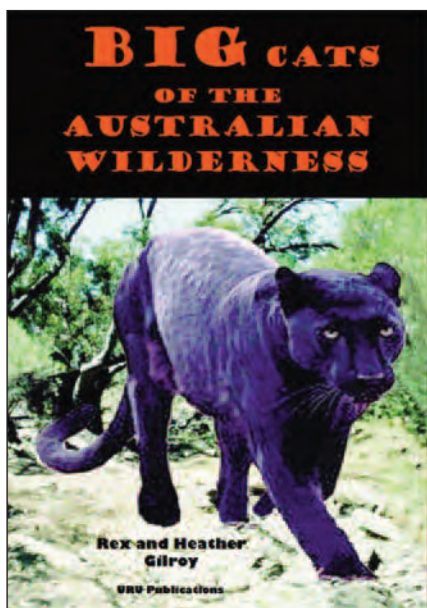
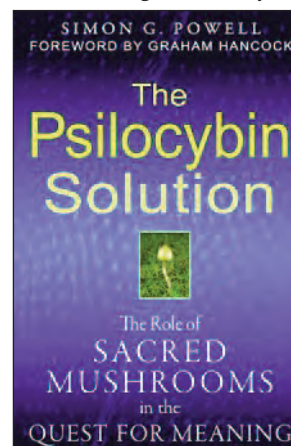

NOW
Available from
URU

Publications.
PO Box 202
Katoomba NSW
2780

Phone 02 4782 3441
Email
randygilroy44@bigpon.com

\$A55 RRP
Plus p&h \$A10 in
Australia,
[overseas prices
on application].

BIG CATS OF THE AUSTRALIAN WILDERNESS

Here, written by Rex Gilroy the 'father' of Australian Cryptozoology and his wife and fellow researcher, Heather is the most important scientifically-based book ever written on the 'Australian Panther' mystery.

The result of ten years preparation, this book goes beyond the usual sightings reports to examine the anatomy and physiology presenting evidence proving these 'panthers'.

Learn about -

- The 19th century 'Big Cat' encounters of our pioneer settlers.
- Mysterious giant marsupial carnivores such as the terrifying 'Blue Mountains Lion', the lion-like killer 'cats' of the New England Ranges of New South Wales and the 'Black Terror Cats' of the Queensland bush, the Cougar giants of Western Australia and more, much more.

Also now back in stock "Blue Mountains Triangle-Secret Underground Australian/American Bases and the ET Connection". [\$AU45 plus p&h \$10].



REVIEWS

ME-FLOW

by Blake Taylor

Yowah Books, NSW, Australia, 2010
ISBN 978-0-646-54531-8 (314pp tpb)

Available: www.yowahbooks.com

Up until the Michelsen–Morley experiment of 1887, it was a given that the aether permeated all matter and life. But that experiment with light rays, and later work by Einstein, almost killed off the notion. For Blake Taylor, it's time to resurrect the concept, and he challenges conventional scientific explanations by interpreting them from a radical perspective with aether at the core.

Taylor chronicles key names and discoveries in physics from ancient Greece to the modern world—including what happened in "the century without aether"—and his summaries make for enlightening and often entertaining reading. The fields that he puts to the test include analytical mathematics, atomic and subatomic physics, electricity, magnetism and light.

Central to his new take is that free-space aether is comprised of elements or even virtual elements of aether in chaotic motion, and that these elements move or vibrate at the speed of light, thus generating free-space pressure. Taylor says that just as there are differences in

conventional "fields", there are also differences in the types of aether flow. He holds that the conventional magnetic field is a "magnetic ether flow", or "me-flow". He theorises that all the atomic forces are caused by the movement of aether and that as aether drains into the electron void, it swirls. He also proposes that the aether nucleus radiates aether spherically at a constant rate. Electrons rove around the nucleus, "gobbling" this high-pressure aether where abundant.

There's much to learn from Taylor's nitty-gritty self-published book.

LESS INCOMPLETE

by Sandie Gustus

O-Books, Hants., UK, 2011
ISBN 978-1-84694-351-5 (321pp pb)

Available: www.o-books.com

In *Less Incomplete*, Sandie Gustus, an instructor at the International Academy of Consciousness in London since 2003, imparts the benefit of her own experience with out-of-body states and the work of Brazilian physician Waldo Vieira, MD, who developed a scientific approach to the study of consciousness. (See Gustus's article in 11/03, and reviews of Dr Vieira's books in 7/03 and 7/06.)

Gustus takes us into a reality where multidimensional consciousness is

made manifest. She discusses physical, energetic and mental bodies, helpers and intruders in transdimensional interactions, and what happens when we die. Past lives, holomemory and retrocognition are all part of her coverage. She says that consciousness undergoes an evolutionary process and that we can better carry out our life plan by advancing into "holomaturity" with a sense of "cosmoethics".

Gustus features accounts of people who've had an OBE and have been able to verify information gleaned in this state. She gives practical advice on how to make the most of this fantastic tool that connects us with transcendent reality and provides more understanding in preparing for the eventuality of death. Inspiring!

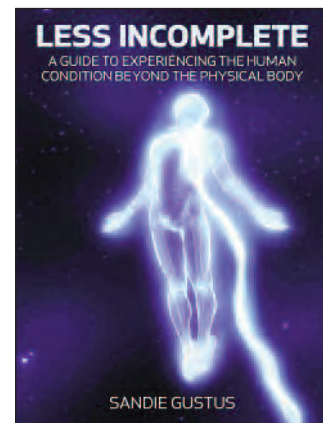

**NUTRITION
BEYOND**

"PRIMUM
EST
NIL
NOCERE"

THE TOTAL
APPROACH

THE TOTAL APPROACH:
COMBINING SCIENCE & NATURE, EAST & WEST

**Cutting-Edge in Prostate Cancer Diagnostics
& Nutritional Medicine**

PCA3, world's first commercially available totally non-invasive genetics test for Prostate Cancer (PCa). **NOW available nationwide!** Far more accurate & reliable than the needle-biopsy. NO more extensive bleeding, pain, high infection risks & most importantly, **missed cancers!** IF you have PCa, your result will tell us how advanced it is. IF you don't, you **DO NOT** have to subject yourself to an unnecessary biopsy: it's **NOT** a "walk in the park" & has a documented 25-35% inherent margin of error (false negative) – in terms of **human life**, this is **NOT** acceptable! **E.U. Regulation-Approved (CE Mark)** in Nov. 2006. For more details, ring Dr.L.Macloud, B.Sc. (1st.Class Hons.), M.Sc., Ph.D, one of the world's PCA3 experts. More info: www.pca3.org/public/experts/australia/lone-macloud
Tel: 02 4342 0125 Mob: 0414 675 384 E: lonesky1@yahoo.com.au

Trisha McCogh's Animal Talk



WANT TO KNOW WHAT YOUR ANIMALS ARE THINKING AND FEELING?
WANT TO LEARN THE SILENT LANGUAGE OF ANIMALS?

2-day introductory workshops.

VENUE: Gold Coast DATE: September 10/11
VENUE: Sydney DATE: September 17/18
VENUE: Melbourne DATE: September 24/25

Private Consultations Available

Communicate with domestic and wild animals

For further details & bookings - see website

0419 999 407

Trisha's Book, Now Available

www.trishamccoghsanimaltalk.com

TRANSDERMAL MAGNESIUM

**No digestion required!
Just relax, sit back, replenish**



Magnesium Chloride Hexahydrate $MgCl_2 \cdot 6H_2O$
Pure salt water source (sodium removed) from
Tibetan Plateau 3,200m above sea level

Elektra MAGNESIUM
Oil / Cream / Flakes

Retail / Wholesale

(07) 5533 1088
www.ElektraLife.com

REVIEWS



UFOs

by **Leslie Kean**

Harmony Books, New York, 2010
ISBN 978-0-307-71684-2 (337pp hc)
Available: www.crownpublishing.com;
UfosOnTheRecord.com

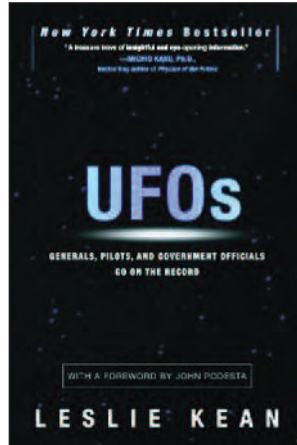

The UFO phenomenon gets a different treatment when a courageous investigative journalist takes up the case. It was only 10 or so years ago that Leslie Kean's interest was sparked when she received the first English version of the French COMETA report and went on to write about it in the *Boston Globe*. She was spurred into action because enough top-ranking retired and serving military, law-enforcement, government and scientific heavyweights were taking the phenomenon seriously.

For her book, New York-based Kean has assembled testimony from many high-level sources, including the retired Major General who investigated the triangular UFO "wave" over Belgium in 1989-90, a former NASA research scientist and aviation safety expert who has a database of over 3,400 first-hand UFO sightings by pilots, and a retired chief of the US FAA's accident division who describes a radar-documented, 30-minute encounter between an aircraft and a huge UFO over Alaska. There are reports from Iranian and Peruvian military pilots scrambled to confront UFO craft, and discussions about the origin of UFO debunking in the USA—when many other nations'

governments are going public and urging the Americans to do so, too.

Kean has many contacts who would only speak off the record, but she has gathered more than enough information, including eyewitness reports, for a compelling case that UFOs exist. She thinks it's high time for a new UFO agency to be set up to engage cooperation between nations.

Even seasoned ufologists should take note, for Kean reveals cases they may not have encountered before.

THE EXTINCTION PROTOCOL

by **Alvin Conway**

Lulu Publishing, NC, USA, 2010
ISBN 978-0-557-65705-6 (571pp tpb)
Available: www.lulu.com

The Earth's systems are all crashing in concert, according to researcher Alvin Conway, and the signs are evident that we're facing extinction. We're on a rendezvous with the Mayan End Time date of 21 December 2012, with no blueprint for survival as Earth changes intensify.

To prove his point, Conway examines the geopolitical world, juxtaposing End Time prophecies with "apocalyptic chess pieces" from the rise of China to Iran as the "trip-wire to Armageddon" with its nuclear plans. Next, he examines evidence for erratic solar behaviour, radiation anomalies in Earth's atmosphere, weather upheavals, mega volcanic eruptions and earthquakes, and the possibility of a killer organism arriving from space. In grappling with religion and philosophy, he considers the 11:11 enigma and other number codes relevant to 2012, the galactic centre in Mayan cosmology, the rebirth of the "god-men", invading demonic spirits, the revival of solar cults, and the future fate of Earth and humanity.

Conway doesn't see much hope for us in the cosmic scheme of things, even if we can find some semblance of human unity, and he draws on dire warnings from biblical and other prophets that suggest we are indeed headed for mass extinction.



REVIEWS

MANIFESTO FOR THE NOOSPHERE

by José Argüelles

Evolver Editions, Berkeley, CA, 2011
ISBN 978-1-58394-303-8 (200pp tpb)
Avail: www.northatlanticbooks.com

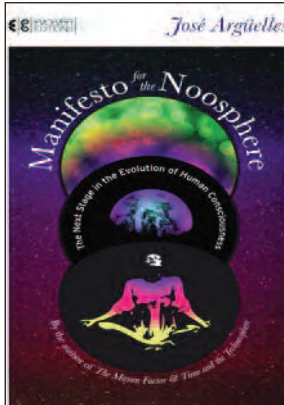

Sadly, José Argüelles won't be around to welcome our heralded connection with the Noosphere on 21 December 2012, as he died on 23 March 2011. The author of *The Mayan Factor* and *Time and the Technosphere* (see 10/01) as well as a key participant in the 1987 Harmonic Convergence meditations, Argüelles has left us with his final testament on the next stage in consciousness evolution.

The concept of the Noosphere ("noh-us-feer") was introduced by the French philosopher Pierre Teilhard de Chardin and the Russian geochemist Vladimir Vernadsky in the early 20th century to define the stratum of human thought consciousness encircling the Earth, which is posited to hold the key to our next evolutionary step. Their thinking had an impact on Argüelles in his belief that we have the power to produce individual mind-shifts to access the collective consciousness of the Noosphere—the Supermind—and create a new era of peace and harmony on Earth and in relationship with cosmic civilisation.

Having already reached intermediate evolutionary stages—the technosphere and cyberspace—we're poised to access a higher consciousness and state of being. The cerebral-terrestrial electro-

magnetic resonance employed by shamans is the same involved in activating what Argüelles calls the "circumpolar rainbow bridge", with its promise for a genuinely planetary art form. The magic begins in 2013—signifier of the complete return to the Mayan 13:20 frequency of universal synchronisation.

Timely last words, and meditation schedules, from a key cosmic thinker of our times.

THE LEGACY OF ZECHARIA SITCHIN

by M. J. Evans, PhD

The Book Tree, San Diego, CA, 2011
ISBN 978-1-58509-136-2 (167pp tpb)
Available: www.thebooktree.com

This book is a fitting tribute to the maverick scholar of the ancient world, Zecharia Sitchin, who died on 9 October 2010, leaving behind a legacy of 14 books including the *Earth Chronicles* series. Skilled in reading the ancient Sumerian cuneiform script, Sitchin was a maverick because his interpretations—including the notion that humanity was genetically manipulated to become a slave race for the Anunnaki visiting from Nibiru—were at odds with those of preceding academics who were focused on myth and had not envisaged space travel.

Zecharia Sitchin backed up his new paradigm with scholarly research, says retired professor Dr M. J. Evans, who met this mild-mannered man in 1995 and proceeded to research his work and join him on tours of important archaeological sites.

Dr Evans praises Sitchin for his contribution to our knowledge about our origins and our possible future, and does justice to his key findings. Her sentiment is reflected in photos from Sitchin's "fans", as he called them, taken on tour with the scholar, and selected memories from devotees who were deeply touched by the man and his work. As new discoveries confirm Sitchin's findings, we can be assured that his legacy will indeed live long and prosper.

Sick and tired of being unwell



Dis-eased Restless Legs burping, Bloating, Gas

Gas can only be made by bacteria and viruses
Remember using 'Sulphur and Molasses' to get rid
of Parasites, worms and viruses in your body?

NOW...New Technology

The ZA-PET™ is HERE

Thousands of these machines have been sold over 12 years with excellent results. Bio-electronic therapy can kill the viruses and parasites in your body, that may cause a wide range of common diseases and viral / parasitic conditions.

Order yours today
\$175au inc



Prevention is better than cure

ALSO available

Hulda Clark books \$65au inc
Malcom harkers 825 \$25au inc

Email: info@za-pet.com

Website: www.za-pet.com

Ph/Fax: 0064 7 541 0028

Mobile: 0064 27 201 3552

Mailing address: 2 Maitland Street
Greerton, Tauranga,
New Zealand.

Did You Know?

Everybody worldwide is infected by at least 12 of over 1000 parasites, bacteria, fungi and viruses that can infect humans.

Get rid of them with the ZA-PET
Our Bioelectronic therapy is based originally on Dr Hulda Regehr Clarks research. She claimed that specific bodily parasites and viruses, often combined with certain toxins may be responsible for a wide range of common diseases. Her protocol of dealing with disease was confirmed at the Albert Einstein College of Medicine by scientists in 1990 resulting in a patent (U.S.#5,188738).

Follow up clinical trial by Prof Henry Lai at the University of Washington confirmed that the zipper selectively kills Cancer cells.(research article at www.drclark.net)
Checkout our website for photos and testimonials



How Healthy is Your Environment?

Introducing memon® technology.

memon® is a complete range of energetic transformers which act to restore your environment to its natural state. memon® was invented over 20 years ago in Germany and now available in Australia.



Products for all applications: There are memon® products for; mobile phones and laptops, vehicles, trucks and boats, drinking water, pools and spas, homes and offices. The combi transformer is FOUR products in one,

neutralizing EMF, RF and geopathic stresses, as well as restore negative ion flow.



Simple installation: No tools or trades people required, all memon® products can be fitted in seconds.

Independently tested: All memon® technology has been independently tested by research laboratories and government agencies across Europe and America. **All tests have shown dramatic improvements.**



More information:

- For your complimentary memon® revolution DVD
- A compilation disk of case studies, test results and testimonials
- To arrange a no obligation inspection at your home or office, or
- Details on becoming a memon® distributor or sales agent.

Visit us:

www.yourenvironment.net.au

Or contact Chris:

support@yourenvironment.net.au

REVIEWS



THE SHEER ECSTASY OF BEING A LUNATIC FARMER

by Joel Salatin

Polyface Inc., Swoope, VA, USA, 2010
ISBN 978-0-9638109-6-0 (321pp tpb)

Available: www.chelseagreen.com;
www.amazon.com

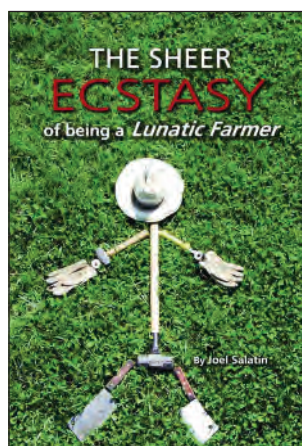

Alternative farmer and writer Joel Salatin can't contain the infectious passion he has for the land and for working it in a sustainable way. Based in the Shenandoah Valley, Virginia, USA, since 1961, Salatin and his family have gone against the grain, favouring perennials over annuals, mobile infrastructure over concrete pens, composting over slurry storage and spreading systems, and localised economics over industrialised production and distribution. Over the years, the Salatins transformed a nutrient-depleted, abused and eroded farm into a thriving, ecology-enhancing, polycultural food production oasis without resorting to toxic chemicals and high-tech production techniques.

Joel Salatin is a self-confessed "lunatic farmer", and in his seventh book he exudes the joy he feels in building bountiful soil and growing luxuriant grass, erecting "crooked" fences, creating ponds, maximising water usage and nurturing the creatures in his care.

Salatin demonstrates a respect for life in all its forms as well as an appreciation for the sheer artistry that's possible by working with

nature and her ways. He revels in producing food and fibre to benefit the community. Indeed, he calls the farm a "rural revitalization engine". He backs up his enthusiasm and his special turn of phrase with sound economics. He's a wonderful role model and success story.

GREECE'S 'ODIOUS' DEBT

by Jason Manolopoulos

Anthem Press, London & NY, 2011
ISBN 978-0-85728-771-7 (292pp tpb)

Available: www.anthempress.com

At the time of writing this review, Greece and other debt-ridden eurozone nations are poised to fall amidst the European sovereign debt crisis and an anticipated double-dip recession in the USA. In *Greece's 'Odious' Debt*, Jason Manolopoulos, the co-founder of an alternative asset management firm, explains how Greece is one small but crucial cog in the global economic crisis but its collapse could have a cataclysmic impact on living standards, near and far. In this drama that has decades of history, many are to blame: Greek politicians and society, trade unions, European Union leaders, the IMF, the world's investment banks, and more.

Greece's economy was already dysfunctional when the global economic crisis hit in 2008, yet it has since been propped up by two bailouts which, foreseeably, failed because of structural problems, a corrupt, inefficient public sector and an unreformed political system. It beggars belief that an already debt-drowning nation could be allowed to borrow in excess of 300 billion euros without the means to escape more "odious" debt, but Manolopoulos sheds light on psychological biases that contribute to systemic, repeated errors. Political and institutional leaders have little time to make the conceptual leaps and changes needed to avert dire economic and social outcomes with years of severe austerity measures. Manolopoulos gives an incisive perspective on this Greek tragedy in the making.



REVIEWS

THE MOST DANGEROUS MAN IN THE WORLD

by Andrew Fowler

Melbourne University Press, Aust, 2011
ISBN 978-0-522-85866-2 (280pp pb)
Available: www.mup.com.au



Daniel Ellsberg, the "Pentagon Papers" whistleblower, suggests WikiLeaks founder Julian Assange could be "the most dangerous man in the world"—an epithet borrowed for the title of this book. Author Andrew Fowler, a respected Australian investigative journalist, interviewed Assange for ABC TV in May 2010—the month after the WikiLeaks release of the damning video of America's "Collateral Murder" in Iraq—and later followed his trail to London.

Fowler traces how Assange got to where he is today—at the time of our writing, awaiting a British High Court decision on extradition to Sweden to answer rape allegations for which he hasn't even been charged. We learn about Assange's early years, his exploits as a cyberhacker with The International Subversives, his personal and work relationships, and his founding in 2006 of the WikiLeaks website—which has become a huge game-changer in politics, journalism and society. We are also given insights into the release of the Iraq video, Afghanistan and Iraq war logs and 250,000 US diplomatic cables, the behind-the-scenes jockeying among the mainstream press selected by Assange to run the leaked material, and reactions to the leaks.

Fowler concludes that Assange is a man of contradictions despite his extraordinary intellect and his firm commitment to social justice, and he wonders whether Assange will achieve the reverse of what WikiLeaks intends and cause governments to increase secrecy and gag free speech. It's a story that's still unfolding.

EXTREME PREJUDICE

by Susan Lindauer

CreateSpace, USA, 2010
ISBN 978-1-45364275-7 (457pp tpb)
Available: <http://extremeprejudiceusa.wordpress.com/>; www.amazon.com

This is the remarkable story of Susan Lindauer, an anti-war and anti-terrorism activist who in 1994 became an undercover CIA and DIA operative, liaising with Iraqi diplomats and intelligence agents primarily at the United Nations. She was involved in starting talks with the diplomats for the Lockerbie trial. By 2002, Lindauer was tasked with passing on threats to the Iraqis that the US would destroy their country should their government not hand over key intelligence materials, so she had forewarning of a war of aggression. She also had advance warnings of the 9/11 attacks and tried in vain to warn relevant US authorities (including her second cousin, Andrew Card, the White House Chief of Staff).

Lindauer relates how in 2004, not long after *she* asked to testify before Congress about pre-war intelligence, she was arrested by the FBI for "acting as an unregistered agent of a foreign government". She was in and out of prison until January 2009, when the five charges against her were dropped quietly, the government saying that prosecuting her "would no longer be in the interests of justice". So much for justice for Susan Lindauer. She's a survivor of what the Patriot Act can do to whistleblowers and dissenters.

Lindauer can take heart from the fact that she's been vindicated. Her book reads like a real-life spy thriller.



HOMEGUARD WATER FILTER

PROTECT YOU AND YOUR FAMILY FROM UNWANTED ADDITIVES IN YOUR WATER.

HOMEGUARD WHOLE OF HOUSE WATER FILTER

- INEXPENSIVE TO INSTALL AND MAINTAIN
- EVERY TAP AND SHOWER IN THE HOUSE PROVIDED WITH CLEAN AND SAFE WATER
- NEVER BUY BOTTLED WATER AGAIN
- MODELS SUITABLE FOR TOWN OR TANK WATER

REMOVES:

- Fluoride and chlorine
- Recycled Water Contaminants
- Household & industrial Chemicals and Solvents
- Pharmaceutical Drugs, Hormones, pesticides
- Giardia and Cryptosporidium
- Chlorine By- Products, Toxins and much more that may be harming your family!

PLEASE RING JIM ATKINSON ON 07 5449 1424 OR EMAIL jim@aquafiltercorp.com.au

FOR MORE INFORMATION AND PROFESSIONAL ADVICE.

REVIEWS



DVDs

Compiled by Duncan Roads

2011 NEXUS CONFERENCE

Produced by E&E Productions, SA, Aust., 2011, www.eande.va.com.au
16 DVDs (60–90mins each)
Available: NEXUS Magazine, PO Box 30, Mapleton, Qld 4560, Australia, tel: 07 5442 9280, website www.nexusmagazine.com

In July 2011, hundreds gathered for our Conference on the Sunshine Coast of Queensland, Australia, for three days and two nights of inspiring talks and presentations. E&E Productions recorded the event and has produced a DVD of each talk. See the NEXUS website for details of DVDs and the complete boxed set.

1. Dangers of Dirty Electricity and EM Fields, with David Stetzer.

Co-inventor of RF meters and filters shows how to detect and neutralise HF voltage transients and EMFs.

2. Remote Viewing and Luck Cycles, with James F. Coyle. *Beyond Belief* author on secrets of mind power, out-of-body states and luck cycles.

3. ESP, Mind Control & Alchemy, with Richard Alan Miller. Physicist and alchemist expands on ESP, mind control and agriculture for a new age.

4. Time-Travelling ETs, with

Linda Moulton Howe. Earthfiles website editor on UFO cover-ups, ET time travellers seeking our DNA, and self-activating symbols and machines.

5. UFO Mystery in Melbourne, with Shane Ryan. Presents his film *Westall '66*, about a UFO mass sighting and the ensuing official cover-up.



6. New Scientific Renaissance, with Professor Robert Pope. Hails a new era of fractal life-science that's our survival blueprint into the future.

7. Sacred Geometry and Consciousness, with Jonathan Quintin. Artist/cosmologist shows how sacred geometry can attune us to the harmony of the universal order.

8. Space Weapons Treaty, with Dr Carol Rosin. Skype presentation,

including NEXUS Editor, on a treaty to ban space-based weapons and plans to link with cosmic cultures.

9. Life After Death, with Barry Eaton. Radio presenter, psychic and *Afterlife* author tackles life after death, life before life and past-life recall.

10. Natural Solutions for Weight Loss, with Sherrill Sellman, ND. Naturopathic doctor on hormone and metabolism balancing in weight loss.

11. The Assault on Our Health Freedom, with Meryl Dorey. AVN founder on governments and vested interests eroding our freedom in alternative health and vaccination.

12. Prophecies of Benjamin Parravicini, with Flor Amanowicz. Psychic intuitive presents spiritual messages from an Argentinian seer.

13. Cosmic Coincidences and 2012, with Pane Andov. Computer scientist turned yogi prepares us for the end of a Great Cycle in 2012.

14. Conversations with Aliens, with Alec Newald. *CoEvolution* author reveals significant new details which his ET hosts say can be released now.

15. CHANI Project and Spiritual Awakening, with Duncan Roads (in lieu of "Acolyte"). NEXUS Editor summarises the work of an insider on CHANI predictions and BEZERK links.

16. Summary Highlights of the Conference on a two-hour DVD.

RADIO OUT THERE

Internet radio for the mind.

Covering everything from the spiritual and alternative to the paranormal.

Presented by Barry Eaton, author of *"Afterlife - Uncovering The Secrets of Life After Death"*.

Listen on www.RadioOutThere.com or download

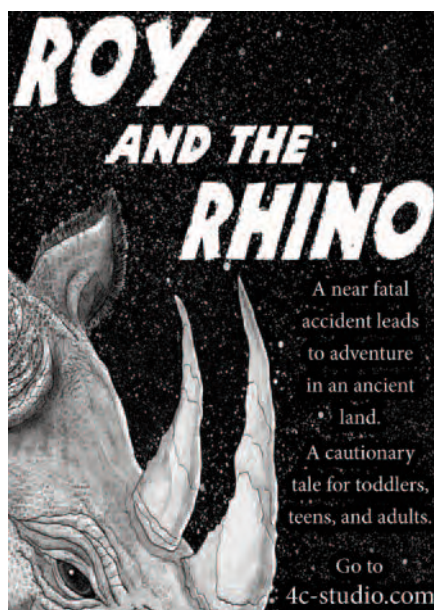

HEAD IN THE SAND?



Are you doing your bit to stop the pharmaceutical take-over?

Find out more at: www.anhinternational.org or call +44 (0)1306 646 600





REVIEWS

MUSIC

Reviewed by Richard Giles

CRYSTAL KEYS

by Lia Scallon

Sounds of Sirius, Aust, 2011 (60mins)
Distributor: **Australia**—Sounds of Sirius, tel (07) 4032 0767, www.soundsofsirius.com

Lia Scallon is a singer, sound healer and channeller. On her ninth album, *Crystal Keys*, Lia's voice and music carry coded crystal key sounds to unlock doorways in the heart and soul, helping us wake up to a new Earth consciousness and heal at the deepest levels. In ancient times, these codes were produced in the sacred sound chambers of Egypt and the temples of Atlantis and Lemuria. Lia provides information about each key sound to help us tune into these powerful crystalline frequencies for healing and upliftment. Her superb vocals carry us to great heights.



ROOTS & WINGS

by Yeshe

World Citizen Records, 2010 (50mins)
Distributor: **Australia**—World Citizen Records, tel (02) 9283 4162, www.yeshemusic.com, www.worldcitizenrecords.com

Yeshe has already made it onto the world music scene with a win in 2008 in the World category of the 16th *Billboard* World Song Contest. On his new global fusion CD, he includes international musicians such as Harry

Manx (Canada), Tefo Hlaele (South Africa), Ganga Giri and Cye Wood (Australia), and Siaka Diarra (West Africa). Yeshe studied percussion under Ghanaian master Mustapha Tettey Addy, and also learned the *mbira* and *kamale ngoni* with other tribal mentors. Here he combines western sounds with African roots for a beautiful, softly global record.

CICADA

by Hazmat Modine

Barbès Records, NY, 2011 (51mins)
Distributors: **Aust**—Diaspora Media/The Planet Company, tel (02) 9283 4162; **USA**—Barbès Records, tel (212) 465 9808, www.barbesrecords.com

The eight inventive musicians of Hazmat Modine create a tone that's earthy and mysterious. They combine steel guitar, harmonicas and percussion with found sounds gathered in their travels around the world. A solid horn section from guest artists the Gangbé Brass Band transforms the musical language. Hazmat Modine is also joined by the Kronos Quartet. *Cicada* is a feast of textures, hues and dynamics from this American group with "a planet's worth of sounds at their fingertips". A worthy, involving and exciting album.

EARTH RESONANCES

by Thomas Chochola

TC Music, Switzerland, 2011 (50mins)
Distributors: **Australia**—NTP Health Products, tel 1800 225 500; **Switzerland**—TC Energy Design, tel +41 (41) 622 0089, tcenergydesign.com

Based on the research of Swiss Bscientist Hans Cousto, this work recreates the harmonising energy of happiness, neutralises noise, energises the immune system, balances overexposure to e-smog, supports therapeutic energy work, and reduces stress and psychic imbalance. The sounds reproduce the resonances of planetary movements and basic life rhythms. Thomas Chochola's music is ideal for the clinic and at home.



FREE CD, valued at \$37, and Special Report Reveal...

"How to Meditate INSTANTLY!"

If you'd like to meditate as deeply (actually more deeply) than a Zen monk, literally at the touch of a button, this may be one of the most important messages you will ever read. Here is why...

Based in part on Nobel Prize-winning research on how "complex systems" (human beings, for instance) evolve to higher levels of functioning, a mental improvement program has been created utilising a powerful audio technology called Holosync®.

A precise combination of audio signals gives the brain a very specific stimulus that creates states of *deep* meditation — and causes the creation of new *mind-enhancing* neural connections between left and right brain hemispheres.

Now a New CD and Report Reveal ...

- The scientific evidence proving how Holosync® increases the production in the brain of many vital neuro-chemicals that can slow ageing.
- How to achieve super-deep meditation, at the touch of a button.
- How to dramatically reduce stress.
- How to create remarkable emotional changes at the deepest level.
- How to improve your emotional health.
- How to heighten your creativity and problem solving ability.
- How to have more restful sleep.
- How to boost your intelligence.
- How to increase your focus, concentration and learning ability.
- How to enhance your memory.
- How to increase your motivation and confidence.
- How to have more happiness and "flow" in your life.
- How to heal emotional blocks.

The complete report on this amazing new technology and Holosync® CD, worth \$37, are FREE to *Nexus* readers for a limited time.

**Call NOW for your
FREE CD and special
report (24 hrs, 7 days) on
Freecall 1800 70 70 47
www.meditate.com.au**

11.11.11

HARMONIC UNIFICATION of GAIA DAY

Grid 44, Wilpena Pound, South Australia

Inviting all Lightworkers, Earth guardians, Shamans, Paganists, Geomancers, Indigenous Peoples, Dream Seeders, Frequency Keepers, Star Seeds, and those that feel drawn to either participate in ceremony or link with our collective thoughts, prayers and meditations towards creating oneness, balance and harmony for the planet and all its inhabitants.

The intention is for 144,000 souls plus worldwide to gather at 11.00am on 11.11.11 and link together with our thoughts-consciousness to choosing and creating that "NEW REALITY" become manifest now. We will be burying a Lemurian Seeded Quartz Crystal and a large Amethyst into the Gridlines and all those participants drawn to do so I would ask that you place a crystal into the Earth for the duration of the ceremony whether you are at a sacred site or not, with the intention of "ONENESS" to traverse the Grid/Ley Lines. To be fully accessible to all life on, below and above MOTHER EARTH.

First we had "Harmonic Convergence" in August 1987 followed by "Harmonic Concordance" of November 2003 and now we have the "Harmonic Unification" on 11.11.11

The first two ceremonies changed our evolutionary blueprint towards a wholeness/unity concept and this 11.11 ceremony will implement that holographic imprint into manifestation for Humanity's Consciousness to accelerate and embrace our Divine Co-creative Powers with "All That Is"

Dream Seeder / ElistRA
Whaledreamer

For more info: Phone JULIA - 03 5988 9242
Email: cosmicangel@bigpond.com



OCCULT KNOWLEDGE & TRUTH

An announcement for genuine seekers **only**

There is a **SECRET** order that teaches the Sublime Occult Mysteries. Many make such claims — few possess the ability to fulfil them. Nevertheless, the Ancient Holy Mysteries have been re-established in order that **GENUINE** seekers may find the **TRUE LIGHT**.

If you wish to study the Ancient Mystery Teachings in their entirety as never before revealed, please write to:

IRS, Dalton House, 60 Windsor Avenue
London SW19 2RR, UK

www.isohtm.org

THOMAS ANDERSON'S CLASSIFIED BOOK SERIES

The Books that the Government, Banks and Corporations don't want you to see...



BOOK ONE



BOOK TWO



BOOK THREE



BOOK 8 COMING SOON!

Don't miss out on the explosive final book in the series!



BOOK FOUR

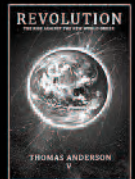

BOOK FIVE



BOOK SIX/SEVEN

ARE YOU PREPARED FOR THE TRUTH?

Contact Kerriane: classifiedbook@gmail.com for details or visit

www.theclassifiedfiles.com

Influenza and the Tuberculosis Connection

Continued from page 22

10. Wade H.W. and C. Manalang, "Fungous Developmental Growth Forms of *Bacillus Influenzae*", *Journal of Experimental Medicine* (Rockefeller Institute of Medical Research) 1920 Jan 1; 31(1):95-103
11. Pfeiffer R.F.J., "Die Aetiologie der Influenza" ("The Aetiology of Influenza"), *Zeitschrift für Hygiene und Infektionskrankheiten* 1893; 13:357-386
12. Hume E.D., *Béchamp or Pasteur?: A Lost Chapter in the History of Biology*, C.W. Daniel Co. Ltd, Ashington, England, 1923
13. Wainwright M., "Extreme Bacterial Pleomorphism and the Bacterial Life Cycle: A Forgotten Controversy", *Perspectives in Biology and Medicine* 1997; 40:407-414, p. 408
14. Flexner S., "Pseudo-tuberculosis Hominis *Streptothricha*", *Journal of Experimental Medicine* 1898 Jul 1; 3(4-5):435-450, p. 437
15. Von Unruh V., "A Comparative Study of the Acid Fast Bacilli", *The Eclectic Medical Journal* (ed. Harvey Wickes Felter) 1916 Jun; 76(6):289-300
16. Stengel A. and H. Fox, *A Text-book of Pathology*, W.B. Saunders & Co., Philadelphia, 1915, 6th ed., p. 298
17. Youmans G.P., *Tuberculosis*, W.B. Saunders Co., Philadelphia, 1979
18. Koch R., "Die Ätiologie der Tuberkulose" ("The Aetiology of Tuberculosis"), *Mitteilungen aus dem Kaiserlichen Gesundheitsamte* 1884; 2:1-88
19. Cornet G., *Nothnagel's Encyclopedia of Practical Medicine. Tuberculosis and Acute General Miliary Tuberculosis*, W.B. Saunders Co., Philadelphia, 1907 ed., p. 483
20. Flick L., "The Hygiene of Phthisis", *The Medical and Surgical Reporter* (ed. Charles W. Dulles) (Philadelphia) 1888 Jan-Jul; 58:136
21. Park W.H., A.W. Williams and C. Krumwiede, *Pathogenic Microorganisms: A Practical Manual For Students, Physicians, and Health Officers*, Lea & Febiger, Philadelphia and New York, 1920, 7th ed., p. 460
22. Hawes J.B. and R.C. Cabot, *Early Pulmonary Tuberculosis – Diagnosis, Prognosis and Treatment*, William Wood and Co., New York, 1918, p. 50
23. Otis E.O., *Pulmonary Tuberculosis: A Handbook for Medical Students*, W.M. Leonard, Boston, 1917, p. 95
24. JAMA, "Influenza or Pulmonary Tuberculosis?" (Editorial), *Journal of the American Medical Association* 1901 Jun 8; 36(23):1628
25. Lindley W., "Influenza and Tuberculosis", *Southern California Practitioner* (Los Angeles) 1901; XVI:338-339
26. Wakley T.H. and T. Wakley, "Influenza", *The Lancet* 1899 Jan 14; 1:103
27. Hendrickson G., "Influenza and Tuberculosis", in: *Transactions of the Minneapolis, St Paul & Sault Ste Marie Railway Surgical Association*, Thirteenth Annual Meeting, Minneapolis, Minnesota, December 17-18, 1920, pp. 149-161, p. 150
28. Baldwin E.R., *Osler's Modern Medicine*, 1913, vol. 1, p. 321

Powerfully Good For You!



- Organic Wheatgrass growing kits
- Organic Wheatgrass trays (pick-up/delivered)
- Super Shots - Skin Care - Juicers - Water filters

Visit us online: bondiwheatgrass.com.au
 Call us on: 02 9694 1100 | 0410 327 077

**REMOVE FLUORIDE
WITHOUT KILLING YOUR WATER**



STOP the search!

TREAT your family to the
ULTIMATE water

ORIGINAL
GRANDER WITH A
FLUORIDE SOLUTION



Free Call: 1800 675 771
www.grander.com.au

Investigating the “Ghosts of the Ocean”

Continued from page 56

According to Smirnov, the appearance of *kvakeri* is associated with a change in the structure of water. Depending on the temperature (which can change due to the Sun's radiation, weather conditions and currents), water acquires different characteristics. Among them is its ability to change volume, and this change creates the croaking sounds and luminescence. This process is invisible on a small scale, but in the huge expanse of the ocean it is displayed distinctively. A passing vessel disturbs water and stimulates its transition from one state into another.

The luminescence of the water can be explained from the point of view of physics; in short, it is visible when there is a concentration of the energy of a large number of disturbed molecules.

The process can start in one area and gradually spread, creating revolving radiant spiral wheels, circles and so on. Smirnov found confirmations of his theory in the fact that *kvakeri* are spread around throughout the global oceans, do not have permanent coordinates and travel with water currents.

They are not very dangerous, although the phenomenon does generate electromagnetic radiation that can cause interference, for example in the functioning of electronic equipment.

Warning of Ecological Catastrophe

According to the World Nuclear Association, at the end of the Cold War in 1989 there were over 400 nuclear-powered submarines operational or being built worldwide. At least 300 of these submarines have now been scrapped, and some on order have been cancelled due to weapons reduction programs.

Today, the USA, Russia, Great

Britain, France and China possess, in total, 160 such submarines.

The Arctic has become a graveyard for the once mighty and feared fleet of Soviet nuclear-powered submarines.

Perhaps the *kvakeri* were attracted to the nuclear submarines in general because of the unpredictable ecological hazards posed to the environment by such vessels. Nuclear submarines everywhere are extremely prone to disaster.

After all, Soviet and Russian

emitted by killer whales during mating, but the *kvakeri* disappeared by 1985 and killer whales keep on mating.

Other researchers (such as those at the Russian Academy of Sciences, St Petersburg, who had been involved in the *kvakeri* project) believed that the mysterious phenomenon was an unknown creature with a high level of intelligence—not a mythical creature, but an undiscovered underwater animal.

Perhaps the Soviet Navy, not interested in ichthyology, accepted this point of view, because in the early 1980s the *kvakeri* research program was abruptly terminated.

Special research groups were disbanded, and the officers who had worked there were given other assignments. All the collected information and data were marked Top Secret and locked away in naval archives.

Neither Vadim Kulinchenko nor other former Soviet officers of his rank know why the program was shut down. The reasons why the results of the research have been classified are quite obvious: Soviet and Russian state military secrets are involved.

Research Files Remain Classified

On 30 July 2009, the Main Staff of the Russian Federation's Navy issued a statement that there are no official documents on encounters between Soviet ships and submarines with unidentified objects.

The source in the Russian naval command said that rumours may arise because commanding officers of ships and submarines must report all objects that cannot be classified but are observed visually and on radar screens.

In such cases, schools of fish, floating rubbish and natural

In Russia, anything related to the nation's naval intelligence and counterintelligence files will not be declassified any time soon.

nuclear submarines have used enriched uranium for fuel (some as highly enriched as 90 per cent). The spent fuel is tremendously radioactive and contains unburned, highly enriched uranium, plutonium and fission products. Russian submarines in the Arctic are corroding and sinking as their reactor compartments fill with water, foreshadowing an ecological catastrophe.

Soviet Research Program Terminated

At the close of 1970s, a scientific conference on the *kvakeri* was conducted by the Soviet Navy, but the participants were not able to reach any definitive conclusions.

The Soviets even attempted to communicate with the *kvakeri*, but were never able to identify whether the reaction from the phenomenon was intelligent.

Some believed the sound was that

Investigating the "Ghosts of the Ocean"

Continued from page 82

phenomena can be mistaken for UFOs.

Those who want to read about this statement in Russian are directed to website <http://tinyurl.com/3k4smxe>.

In Russia, anything related to the nation's naval intelligence and counterintelligence files will not be declassified any time soon. The reasons are obvious.

The former chief of the information (naval intelligence) centre of Russia's Northern Fleet, Captain 1st Rank Anatoly Smolovsky, stated:

"The Russian Navy Main Staff has information about fifteen thousand sounds of unknown nature, registered by Soviet and Russian seamen. This information pertains to Russian nuclear submarine cruisers' routes, and, as such, is in direct relationship with Russia's security. Hence, such data will remain secret in the near future."

Smolovsky's statement comes from an article by Andrei Moiseyenko and Natalya Lebedeva, published in the Russian newspaper *Komsomol'skaya Pravda-Vladivostok* (2 November 2008), titled "NLO: *kvakayuschiye v okeane*" ("UFO: those who croak in the ocean").

As for the former submariner Kulinchenko, he tried to collect whatever information was available short of opening the secret files.

It's been over 20 years since the disintegration of the Soviet Union and, still, very little information about the *kvakeri* has leaked out. Even those who have researched the phenomenon have very different opinions as to its nature.

Apparently the phenomenon is not being researched officially at present, but there are those in Russia who are dedicated to finding out the truth about the mysterious *kvakeri*. After all, they could come back... ∞

About the Author:

Paul Stonehill is a researcher, author and lecturer specialising in anomalous phenomena, especially Soviet and Russian military research into the subject. He is the author of numerous articles for UFO-related magazines and several books, including (with Philip Mantle) *UFO Case Files of Russia* (11th Dimension Publishing/Healings of Atlantis, UK, 2010; see review in NEXUS 17/05), *The Soviet UFO Files: Paranormal Encounters Behind the Iron Curtain* (Quadrillion Publishing, UK, 1998), *UFOs na Russia* (Brazil, 2009) and *Expediente Soviet UFO* (Spain, 2010). Paul's latest book is *Paranormal Mysteries of Eurasia* (Galde Press, 2011, USA). His article "Soviet UFO Sightings in International Waters" was published in NEXUS June-July 2011 (18/04).

Paul Stonehill is fluent in Russian and Ukrainian, and can be contacted via email at rurcla@hotmail.com.

www.anotherparadigm.com

for people who dare to think for themselves
who have the courage to follow their own path

Journey to major megalithic sites in
Peru & Bolivia

Oct 31st – Nov 14th 2011

Machu Picchu, Cusco, Ollantaytambo, Sacsayhuaman,
Qoricancha Qenqo, Písac, Amaru Muru, Uros Islands,
Island of the Sun, Island of the Moon and more... and the
mind blowing

Tiwanaku and Puma Punku

Where will you be
on 11.11.11?

hopefully in a protected place...

or you can still be with us

in the safe energy of the Island of the Sun, Lake Titicaca

*** ask for availability ***

a unique opportunity to be on this most amazing place
during the tremendously powerful frequency of 11.11.11.
What you will learn and experience there, amplified by the
frequencies of 11.11.11, will really broaden your mind.

www.anotherparadigm.com

has unique tools to help you through this powerful

shift of energy & extend your consciousness

contact@anotherparadigm.com

Check for New destinations to come!

DEHYDRATORS-NUTCRACKERS-GRAINMILLS-WELLNESS WATER PURIFICATION

SURVIVAL

**PRIORITY ONE: PURE WATER FROM A
PUDDLE, READY TO DRINK,
WITHOUT CARRYING THE WATER AND
WEIGHT?**

Portable Life Saver Water Bottles/Jerry Cans



LB Healing Products

Ph: 02 6373 3419

www.grainmills.com.au sales@grainmills.com.au

ANTIPARASITE HERBS-MANUAL & ELECTRIC JUICERS-COCONUT OIL-HIMALAYAN ROCK SALT LAMPS-DISTILLERS
SOLAR COOKERS-HEALTHY MIRACLE LIQUID SOAP-MIRACLE LAUNDRY BALL-VACUUM SEALERS-SHOWER FILTERS
SMOKERS-AIR IONISERS-LIFESAVER WATER BOTTLE-ORALMAT-BOOKS-BLENDER

13-Moon Diary of Natural Time 2011-2012

by Nicole E. Zonderhuis & Sylvia Carrilho

The 260-day Tzolkin calendar was a gift of the prophetic Maya to the people of today. It is a tool to synchronize to the changing energies and transformation of 2012. In the Tzolkin calendar each of the 260 days has a specific energy attached to it. Each day has its own 'face', its identity or character, which influences its events, a person's luck at the moment, or even his fate.

Translated by José Argüelles the diary is an easy-to-use day planner in which you instantly glance what day it is according to the Gregorian calendar, as well as the 13 Moon Calendar. You can learn about the day-energies and plan your activities accordingly. All 13 Moon tables are included. Naturally, it has all the features of a contemporary diary, including a moon planner, when-is-when calendar and menstrual cycle calendar. This diary is produced with loving care, in full color, featuring beautiful illustrations and allowing space for note taking.

- 176 pages • Full colour • page size 13 x 20 cm
- bound with bookmarker and elastic • Pocket in backcover



To order, visit www.nexusmagazine.com

WATER OZONATOR

Designed to freshly ozonate a glass of drinking water

Ozone is nature's purifier

Enjoy the fresh taste and benefits of added oxygen

Contact: NTP Health Products
E: marketing@ntphealthproducts.com
T: 1800 225500

START BUILDING YOUR FUTURE NOW!

Business Opportunity with a patented, breakthrough botanical that releases adult stem cells in the body to promote optimal wellness. **Independent Distributors are the ONLY SOURCE for StemEnhance**



Janet Brien 0433 111 742
Marita Mason 07 412 88234

H₂O₂

HYDROGEN PEROXIDE (FOOD GRADE)

FOR FARM AND GARDEN

20 LITRE DRUM

SPECIAL PRICE: \$220.00 (incl GST) PLUS FREIGHT

Contact: NTP HEALTH PRODUCTS
PHONE: 02 4997 2530
E: mail@ntphealthproducts.com

No more embarrassing smelly gases

Black zinger cleans and reconditions your colon



BLACK ZINGER

Roasted Brown Rice Drink
T: 02 49684825
or 07 41595647
www.blackzinger.com.au

Stocktake Sale

NOW ONLY

\$29.95 per pack

Slashed from \$49.95

BOOKS, TAPES, MAGAZINES & VIDEOS

E-BOOK: 2012-NEW-EARTH-SURVIVAL.COM. A guide for the Paradigm Shift & Exodus. Planet-X, Earth Changes, Illuminati, Spirituality, Ascension, Jesus & ET's Rescue Plan.

BOOK: "PLANETS, SUNSPOTS AND EARTHQUAKES". The gravity trigger effect for solar flares, earthquakes and volcanic eruptions. A new cycle is now starting – this could mean more earthquakes! More details at www.planetinfluences.com.

CLIMATE CHANGE - EXPLAINED BY MAGNETISM? ISBN 978-0-646-47722-0. Rediscovered Climate Change, Magnetism and Gravity. All these elements are free. See review in NEXUS Vol.17 No.1. AU\$87.50 inc. p&h (for Australia AU\$71.50) or a CD (PDF) \$25 inc. p&h. Payment: Bank Money Order, Cheque, to Thomas T. S. Watson, 32 Kinlock Street, North Geelong, Victoria 3215, , or for direct transfer payment details ttsw@bigpond.com

YOUR WISH IS YOUR COMMAND 14 Disc CD Series. Referred to as the 'Think and Grow Rich' of our time. A must have CD series for anyone serious about experiencing real change in their life. Normally \$300. Special Price Aust. \$35 incl P&H. Overseas AUD \$40 incl. P&H. Send cheque or money order to M Benbow, PO Box 81, Lockwood South, Vic. 3551 Australia. Direct deposit details email mbbenbow@gmail.com

LIVINGARCHITECTURECENTRE.COM - "Inspiring", "Fabulous", "A breath of fresh air!"

SOVEREIGN PICTURES IS A NEW and independent all-media production house based in Western Australia. In our time of accelerated Earth changes, our vision is to deliver content raising human awareness of themselves as wholly sovereign beings. Our mission is to deliver each project with an into-the-heart feel for the matter using the best technology and craftsmanship to tell the story. www.sovereignpix.com

BOOKS, TAPES, MAGAZINES & VIDEOS

APOCALYPSE OR A GOLDEN AGE? www.eande.va.com.au plus NEXUS Conference dvds available

GEOMANTICA.COM - FREE WEB MAG, books, films & education at the cutting edge of geomancy.

HEALTH PRODUCTS, SERVICES, COURSES

AURA GOGGLES SPIRIT PHOTOGRAPHY, Egely Wheels, EMF Protection devices, Biofield Imaging. Australia's leading energy product experts, www.pranaview.com.au

A HEALING BREAKTHROUGH: ZERO POINT ENERGY WAND. Colloidal Silver Generators & COLSIL gel, Clark's zappers, Silver Electrodes, www.wanderwand.com info@wanderwand.com 0405 686 487 Queensland, Australia

DEVELOP AURIC SIGHT and telekinesis at home using Pranaview2 Aura Goggles and the Egely Wheel. Australia's leading experts in energy technology, www.pranaview.com.au

EARTH ENERGIES, SACRED GARDENING, nature spirits. Geomancy training with Alanna Moore in Dunedin, Oct 29th, ph - 03 453 1239.

EMF METER (BRAND NEW) - Measure electromagnetic hazards scientifically. \$139.95 including delivery. Visit www.biostim.com.au

FOR EFFECTIVE, GUARANTEED SOLUTIONS for 1) Energizing water (www.energizewater.com), or 2) Neutralizing geopathic stress and electro-stress and EMFs in the home/office and on the body (www.geopathic-stress.info), or 3) Eeman/Relaxation screens which also provide a way to transmit any healing substance vibrationally to the body (www.biocircuits.info), contact Tim Strachan of The Energy Store at ts@energystore.biz, or phone (02) 9388 9994, or skype id strackone. And/or become a distributor/onseller.

HOLISTIC HOME STUDY DIPLOMAS. See our new website www.ukcollege-holistic.co.uk

HEALTH PRODUCTS, SERVICES, COURSES

HULDA CLARK 9 VOLT ZAPPERS \$167, Robert C. Beck, D.Sc 27 Volt Zappers \$227, Colloidal Silver Generators 24 Volt \$140. Phone: (07) 4638 9035

RADIONIC DEVICES and energy pendulums. Neutralise geopathic stress, balance subtle energy fields. www.emeraldinnovations.co.uk

REPAIR, RESTORE, RENEW YOUR BODY through the increase of release of your own Adult Stem Cells! To facilitate this process, nature has provided a unique nutrient only available from one plant source. For a FREE DVD and information please call: Phone (07) 4638 9035. Brian Wilkinson, Herbalist & Nutritionist www.joyelement.net

SPIRITUAL HEALING. Humans / Animals. No fees. www.billlynnharry.co.uk

LIVING ON THE LAND

FOR SALE 400AC IN THE LUSH BELLINGEN VALLEY NSW Australia. Ideal for the self-sufficient life style or community living. Escape the system, drink clean water and grow organic food. AU\$390,000. +(02) 6655 2551, p.rb@live.com.au.

WWW.SURVIVALSTOREHOUSE.COM Australian distributor of Mainstay emergency food & water. *5 year shelf life*. In fair weather, prepare for foul.

MISCELLANEOUS

FUTURE FRIENDS AND LOVING PARTNERS, all ages, UK or overseas. Magazine established 1984. No membership fees. Person to Person (NX), PO Box 40, Minehead, TA24 5YS, UK. T: 001144 1643 709 509.

ENTERING THE DRAGON. Earth's journey into a black hole. website at: <http://www.soul-search.org/beyondthewheel.html>

PERSONAL GROWTH

PROPHETIC PAINTINGS: online gallery www.wendricharhouse.com

DE-CLASSIFIEDS

88c per word incl. gst

GURDJIEFF: TEACHINGS / GROUPS / movements/music. www.google.co.uk

NEW DISTANCE DEGREES WEBSITE. Calamus International University. www.unicalamus.org
info@unicalamus.org

LEARN TO DISSOLVE YOUR ISSUES directly (anxiety, phobias, low energy conditions, etc.) using a revolutionary but simple new method of energy work (not EFT). 3 sessions are usually sufficient to learn how to do this yourself. Guaranteed improvement if you practise these techniques. In person (Sydney) or by phone. More info www.energy-body-work.com. Call Tim Strachan 02 9388 9994.

TRAVEL

SRI LANKA. RAINBOW TOURS - your Partners in Paradise! www.rainbowtourssrilanka.com We offer: Whale / Dolphin watch, Surfing, Diving, Exotic Ceremonies and

Honeymoons, Cultural Island Tours, Jungle Trekking, Ayurvedic treatments and meditation Retreats, and 'chill out' Beach holidays - amongst much else. Good English spoken and safe driving! Advice / quotes: simonpeter@www.me.uk

UFOs & THE UNEXPLAINED

UFO HOTLINE: 1800 77 22 88
UFO RESEARCH QUEENSLAND Monthly public meetings, library, membership, nightwatches, conferences. (07) 3376 1780.

SCIENCE & TECHNOLOGY

IMPROVE ENGINE HORSEPOWER <http://xcelplus.com.au>
WWW.NOTSOPHYSICALPHYSICS.NET A guide to understanding reality.

FOR UFO TECHNOLOGY Consult Australian Gravitational Space Propulsion Research Innovations www.agspri.com

NOT SO FAST, DR. EINSTEIN, disproof of Special Relativity, www.klman.com/physics

READ THE MOST SENSATIONAL, but never heard before space discovery. Seriously scientific. www.urigalaxypublications.com. Apart from science, comments are included on the possibility of Solar UFOs existence.

REDUCE ENGINE FRICTION <http://xcelplus.com.au>

REDUCE ENGINE TEMPERATURE <http://xcelplus.com.au>

PERMANENT ENGINE PROTECTION <http://xcelplus.com.au>

GET ACQUAINTED TO THE UNKNOWN, irrefutable cosmological theory and also to Solar UFOs. The book is free of charge. Pay for postage only, www.urigalaxypublications.com.

IMPROVE ENGINE STARTING <http://xcelplus.com.au>

The Bion Ring

Electro-magnetic Protection

- The Bion Ring, based on the design of an ancient ring discovered in the Valley of the Kings in Egypt in 1860
- thought to have originated in Atlantis
- utilizes geometric forms placed and balanced to a lost system of ancient knowledge.
- The Bion Ring tunes the wearer's subtle energy fields creating a powerful barrier against electro-magnetic, psychic and other stressors



Original ring - a copy of the original ring was worn by Howard Carter during his excavations of King Tut's tomb



Bion ring design voted most potent human energy assist by one of Europe's leading health/consciousness magazines



recommended by health professionals

Kinesiology, EAV, pulse diagnosis, Kirlian and now new remarkable daylight photography confirm the Bion technologies to be potent bio-resonance tools promoting rapid healing, and consciousness activation/protection

THE BION RING: REDUCED STRESS, RAPID HEALING, EMOTIONAL BALANCE, ENHANCED MIND FUNCTION AND JOY OF LIFE!



Bion pendant with keshi pearl



Bion pendant with ruby and keshi pearl

The Bion Pendant

The Bion pendant provides additional protection and can be worn on its own or with the Bion ring for maximum effect, as well as for amplifying the properties of healing gems set within it.

Actual unretouched photo showing invisible to the eye Bion geometries



Bion ring Kirlian photo

LIFE FORCE SUBTLE ENERGY TECHNOLOGIES
 Bion ring in pure silver: \$175
 Bion pendant (22ct gold/pure silver): \$350
 Please add \$10 shipping per order.
 Please send money order to: Life Force S.E.T
 Box 916, Byron Bay, NSW, 2481, Australia
 Or order online with credit card from:
www.visionutopian.com.au
 ph. 0412-317421 email: mark@lis.net.au

DVDs available through NEXUS

NEXUS MAGAZINE

1987-2010

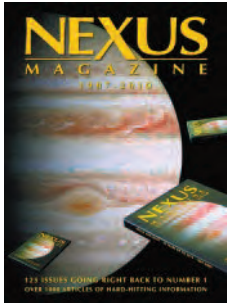

This DVD contains the complete back issues of NEXUS from 1987-2010 in pdf format.

Reconnecting to Nature Through Spiritual Permaculture by Leonid Sharashkin



The Ringing Cedars editor reveals worldwide potential for Russia's permaculture garden movement.

The School: Humanity's New Future



At this Russian school, the children have designed, built and decorated their own campus.

Creating Your Space of Love: The Road Home



Family domain and eco-village planning, presented by Leonid Sharashkin in Byron Bay.

Ancient Roots, Modern Shoots

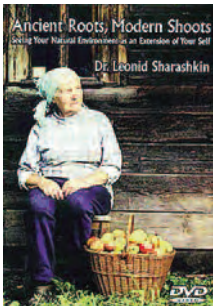

"Seeing Your Natural Environment as an Extension of Your Self" by Leonid Sharashkin.

Recreating A Garden Planet

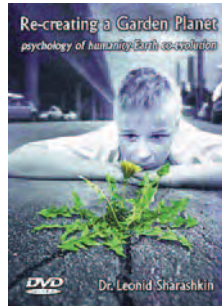

Psychology of Humanity-Earth Co-evolution. Presented by Leonid Sharashkin.

The Eternal Cycle

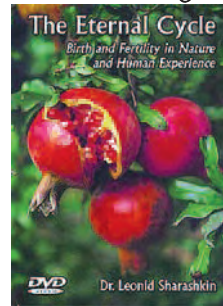

Fertility and Birth in Nature and Human Experience. Presented by Leonid Sharashkin.

The Return of Anastasia



Leo Sharashkin explains the significance of the Russian *dacha* gardening movement.

The Harmonic Code by Bruce Cathie

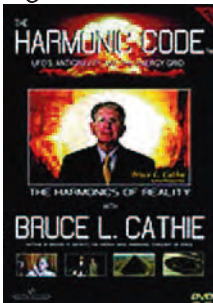

"UFOs, Antigravity and the Energy Grid". Matter, antimatter, time travel, harmonic mathematics etc.

Vaccination: The Hidden Truth



Their ineffectiveness, the manipulated statistics and what vaccines contain exposed in this DVD.

NEXUS Conference DVDs - 2007

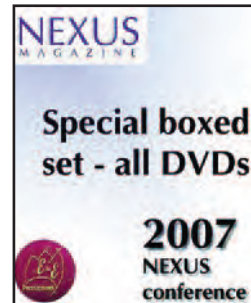

Harry Oldfield, George Wiseman, Sherrill Sellman, Meryl Dorey, Dr Ted Loder and more.

NEXUS Conference DVDs - 2008



Ringing Cedars, Crystal Skull, Harry Oldfield, Callum Coats, Gary Opit and more.

To order visit www.nexusmagazine.com

Books available via NEXUS on Ancient Mysteries and Travel Archaeology/Mysteries

The Giza Death Star



This is physicist Joseph Farrell's amazing book on the secrets of the Great Pyramid of Giza.

2012 and the Shift of Ages



A Guide to the End of the World by Alexander Price. Investigates the cycles of human history and nature.

Sunken Realms

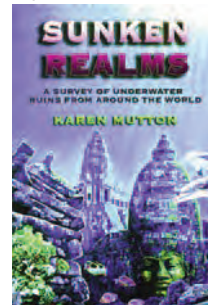

A Survey of Underwater Ruins From Around the World. Includes discussion on causes of sunken cities.

Lost Cities & Ancient Mysteries of the Southwest

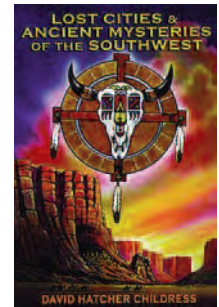

David Hatcher Childress traverses the American Southwest investigating archaeological mysteries.

Axis of the World



A Multi-disciplinary approach across the Americas in search of the oldest American civilisation.

The Hollow Earth

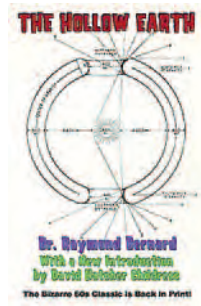

Dr Raymond Bernard's bizarre 60s classic is back in print! New intro by David Hatcher Childress.

The Lost Continent of Mu



James Churchward's classic on the theory of a lost continent in the Pacific. First published in 1931.

In Secret Tibet



Reprint of a rare 1930s travel book by a German traveller who travelled through forbidden Tibet.

Danger My Ally

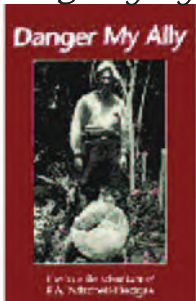

The true life adventure of F.A. Mitchell-Hedges including his discovery of the famous Crystal Skull.

Land of the Gods

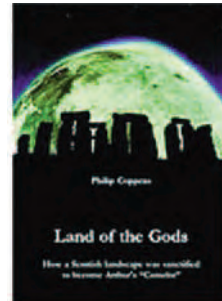

How a Scottish Landscape was Sanctified to Become Arthur's Camelot by Philip Coppens.

The Lost Science of Measuring the Earth

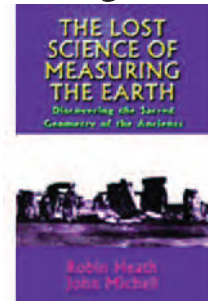

Discovering the Sacred Geometry of the Ancients by Robin Heath and John Michell.

Maps of the Ancient Sea Kings



Charles Hapgood's classic 1966 book on ancient maps and world civilisation before Ancient Egypt.

To order visit www.nexusmagazine.com

Conspiracy & Religious Revisionism/Mysteries available via NEXUS (selection only).

Hitler's Suppressed,
Still-Secret Weapons,
Science & Technology
by Henry Stevens



Intelligence reports of supermetals, electric guns, & ray weapons, x-ray and laser weaponry.

Weather Warfare
by Jerry E. Smith

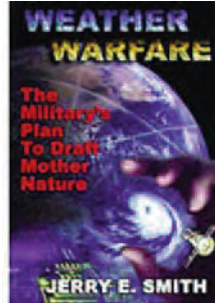

The Military's Plan To Draft Mother Nature. HAARP, environmental & weather-modifying technologies.

ParaPolitics:
Conspiracy in
Contemporary
America



Collection of Kenn Thomas' lecture remarks, interviews and articles from the world's underground press.

From Major Jordan's
Diaries
by George Racey

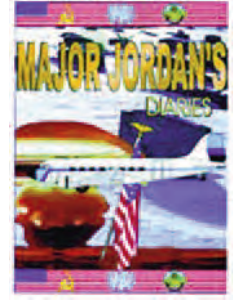

Diary account of high-level cooperation between Russia and the USA since World War II.

The Secret Vault
by André Douzet and
Philip Coppens



The Secret Societies' Manipulation of Sauniere & the Secret Sanctuary of Notre-Dame-de-Marceille.

Mind Control, World
Control
by Jim Keith



Veteran conspiracy researcher's overview of mind control as a tool of the New World Order.

The Shadow
Government

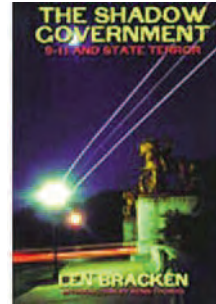

9-11 and State Terror, by Len Bracken, with introduction by Kenn Thomas.

Secrets of the Holy
Lance



The Spear of Destiny in History & Legend by Jerry E. Smith and George Piccard.

Mary Magdelene
The Illuminator

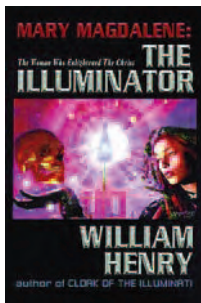

The Woman Who Enlightened The Christ by William Henry.

They Lied to Us in
Sunday School

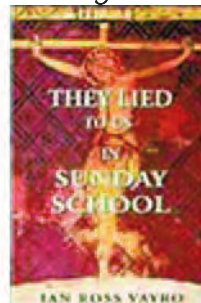

Ian Ross Vayro takes us through ancient biblical texts leading one to question traditional teachings.

The Papal Billions
by Tony Bushby



Damning facts about the Vatican's accumulation of wealth over the centuries.

The Twin Deception
by Tony Bushby

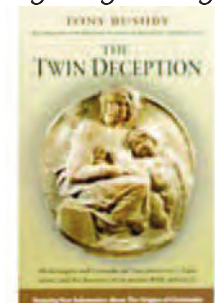

Reading like a suspense novel, this book unlocks the concealed evidence of Jesus' twin brother.

To order visit www.nexusmagazine.com

Books available through NEXUS—Environment/Spirituality and Alternative Health

Ringing Cedars Series
by Vladimir Megre



The author's fascinating experience of Anastasia and the ringing cedars of Russia.

13-Moon Diary of
Natural Time
2010-2011



Red Overtone Moon Year. Contains Mayan 13-Moon calendar, horoscope, planner & short guide

Stone Age Farming
by Alanna Moore



Eco-Agriculture for the 21st Century—a holistic, practical approach to farm & ecosystem management.

How to Survive 2012

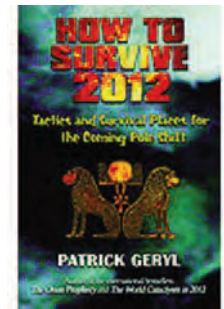

Tactics and Survival Places for the Coming Pole Shift by Patrick Geryl.

Living Energies
by Callum Coats

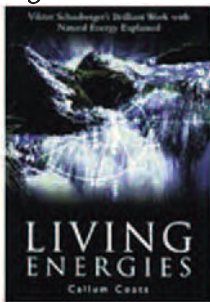

Viktor Schauberger (1885-1958) & his brilliant ideas & inventions harnessing natural energy explained.

Hidden Nature
by Alick Bartholomew



Describes Schauberger's work with water as a living organism. Foreword by David Bellamy.

Voyages Into the
Unknown



Bruce Moen's forays into the afterlife, including his experience in helping 'retrieve' individuals.

Ley Lines and Earth
Energies
by D Cowan & C Arnold

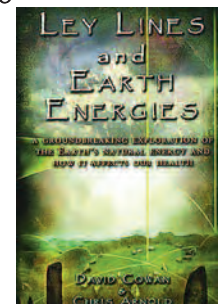

A groundbreaking exploration of the Earth's natural energy and how it affects our health.

Silent Fields
by Donna Fisher

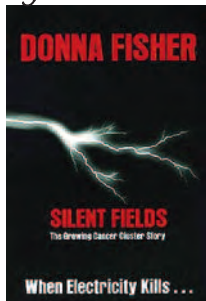

The Growing Cancer Cluster Story—an exposé on the power industry & "dirty" electricity.

Every Breath You
Take

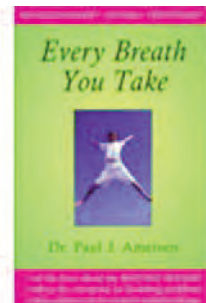

Help for asthma sufferers with information on the Buteyko Method by Dr Paul Ameisen.

The Golden Fountain

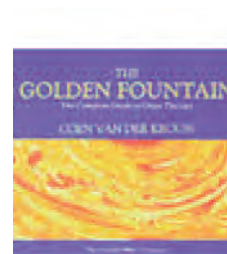

The Complete Guide to Urine Therapy by Coen van der Kroon.

Behavioural Problems
in Childhood

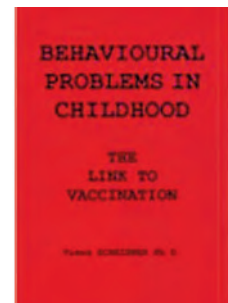

Neurological & behavioural disorders and the link to vaccines by Viera Scheibner PhD.

To order visit www.nexusmagazine.com

Suppressed/Frontier Science & Free Energy
A selection of books available from NEXUS

The Energy Machine of T. Henry Moray by Moray B. King

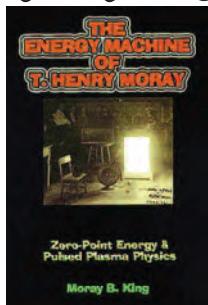

Zero-Point Energy & Pulsed Plasma Physics. 1920s energy device explained by modern science.

Prodigal Genius by John J. O'Neill

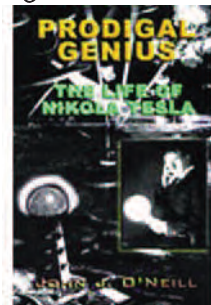

Nikola Tesla is revealed as a figure of genius whose influence on the world reaches into the far future.

The Fantastic Inventions of Nikola Tesla Compiled by Childress

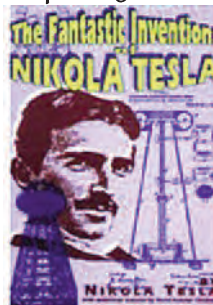

Compendium of the inventions of the originator of electrification. Includes patents, diagrams, photos.

Harnessing the Wheelwork of Nature ed Thomas Valone



Essays, papers, technical briefings and press clippings dedicated to Tesla's work and memory.

Adams' Pulsed Electric Motor Generator Manual

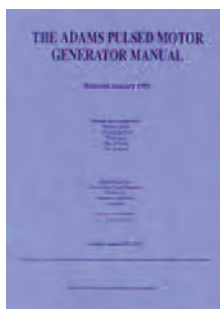

This is the manual which further describes the details on how to build the Robert Adams motor.

The Adams Manual - Addendum

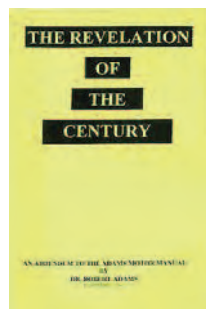

This addendum further updates the research and theory surrounding the Adams' Motor.

Perpetual Motion by Arthur Ord-Hume

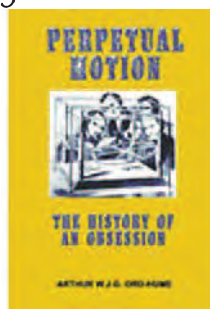

A present-day engineer finds perpetual motion seekers were important in engineering's history.

The Free-Energy Device Handbook

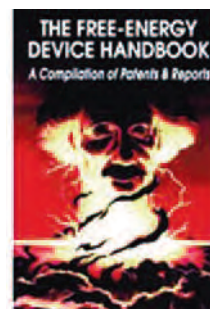

A compilation of patents, diagrams, descriptions and reports, edited by David Hatcher Childress

Gravitational Manipulation of Domed Craft

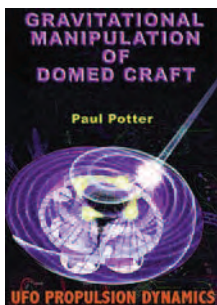

UFO Propulsion Dynamics by Paul Potter. Research based on crashed UFOs from Russia and America.

The Anti-Gravity Handbook



Edited by David Hatcher Childress. Free Energy, Flying Saucer Propulsion, UFOs, NASA Cover-ups.

The Energy Grid by Bruce Cathie

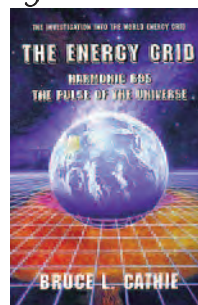

Breakthrough book that explores the incredible potential of the Energy Grid and Earth's Unified Field.

The Tesla Papers by David H. Childress



Tesla's vision of the future, including wireless power, anti-gravity, free energy & advanced solar power.

To order visit www.nexusmagazine.com

A selection of books on UFOs and the Unexplained available through NEXUS.

SOLOMON ISLAND MYSTERIES
by Marius Boirayon

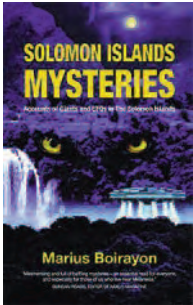

Giants of the Solomon Islands; UFO underwater & underground bases deep in the jungle.

COEVOLUTION
by Alec Newald



The life-changing true story of a man taken for ten days to an extraterrestrial civilisation.

CONTACT:
Countdown to Transformation
by Steven M Greer

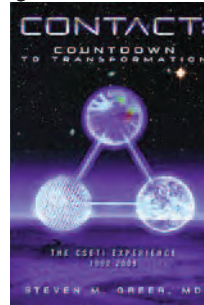

Chronicle of the CSETI team's experience of contact from 1992-2009. Includes bonus DVD.

HIDDEN TRUTH:
Forbidden Knowledge
by Steven M Greer

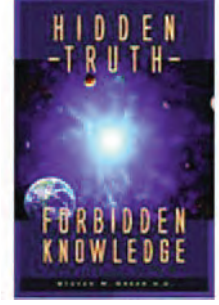

From UFO sightings to meetings with CIA directors, join Greer on his discovery of secret agendas.

UNDERWATER &
UNDERGROUND
BASES

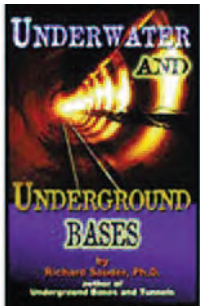

Dr Richard Sauder's evidence & govt paper trail for the construction of huge bases on & offshore.

STALKING THE
TRICKSTERS



Investigation into Shapeshifters, Skinwalkers, Dark Adepts and 2012 by Christopher O'Brien.

REICH OF THE
BLACK SUN



Nazi Secret Weapons & The Cold War Allied Legend by historian and physicist Joseph P. Farrell

THE GREAT AIRSHIP
OF 1897

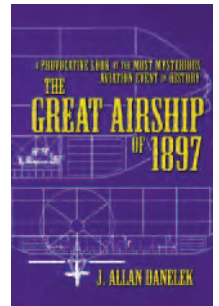

A Provocative look at the Most Mysterious Aviation Event in History by J. Allan Danelek.

UFOS AND
ANTI-GRAVITY
Piece for a Jigsaw



Scientist Leonard G. Cramp's 1966 classic on flying saucer propulsion & suppressed technology.

UFOS, PSI &
SPIRITUAL
EVOLUTION

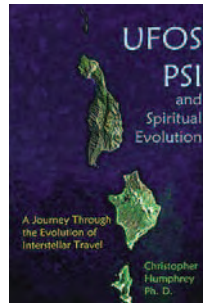

A Journey Through the Evolution of Interstellar Travel by Christopher Humphrey PhD.

NAZI
INTERNATIONAL



The Nazi's Postwar Plan to Control Finance, Conflict, Physics and Space by Joseph P. Farrell.

THE LUCID VIEW



Investigations into Occultism, Ufology and Paranoid Awareness by Aeolus Kephap.

To order visit www.nexusmagazine.com

ADVERTISING RATES 2011–2013 (prices include GST)

DESCRIPTION	SIZE (ht x width)	AUST EDN.	USA EDN.	UK EDN.	NZ EDN.
FULL PAGE (B&W)	240mm x 180mm	\$990	US\$750	£500	NZD\$650
2/3 page vertical	240mm x 115mm	\$770	US\$600	£400	NZD\$500
2/3 page horizontal	160mm x 180mm	\$770	US\$600	£400	NZD\$500
1/2 page vertical	240mm x 87mm	\$550	US\$425	£275	NZD\$350
1/2 page horizontal	120mm x 180mm	\$550	US\$425	£275	NZD\$350
1/3 page vertical	240mm x 58mm	\$385	US\$275	£200	NZD\$250
1/3 page horizontal	80mm x 180mm	\$385	US\$275	£200	NZD\$250
1/4 page vertical	120mm x 87mm	\$330	US\$250	£175	NZD\$190
1/4 page horizontal	60mm x 180mm	\$330	US\$250	£175	NZD\$190
1/6 page vertical	120mm x 58mm	\$220	US\$200	£150	NZD\$150
1/6 page horizontal	80mm x 88mm	\$220	US\$200	£150	NZD\$150
1/8 page (Bus.Card)	60mm x 88mm	\$198	US\$150	£100	NZD\$125
1/9 page (standard)	80mm x 58mm	\$165	US\$125	£100	NZD\$100
Display Box (vert.)	80mm x 44mm	\$132	US\$100	£ 75	NZD\$ 90
Display Box (horiz.)	60mm x 58mm	\$132	US\$100	£ 75	NZD\$ 90
De-Classifieds		88¢ p/word	\$1- p/word	35p p/word	60¢ p/word
Outside Back Cover		\$2,750	US\$1,300	£1200	NZD\$1,200
Inside Front Cover		\$2,200	US\$1,100	£1000	NZD\$1,000
Inside Back Cover		\$2,200	US\$1,100	£1000	NZD\$1,000
Inserts		\$88 per 1000	POA	POA	POA

THINGS YOU SHOULD KNOW:

- 1) Each international edition of NEXUS is identical, except for the advertising.
- 2) Payment **MUST** accompany finished artwork. Artwork should be emailed as an attached pdf file.
- 3) Discounts do exist for multiple issues - but **ONLY** if pre-paid.

ADVERTISING SCHEDULE 2011–2012

Issue #	On-sale period	Booking d/line	Artwork d/line
Vol. 19 #01	Dec 2011–Jan 2012	22nd Oct 2011	29th Oct 2011
Vol. 19 #02	Feb-Mar 2012	20th Dec 2011	5th Jan 2012
Vol. 19 #03	Apr-May 2012	20th Feb 2012	27th Feb 2012
Vol. 19 #04	June-July 2012	23rd April 2012	30th April 2012
Vol. 19 #05	Aug-Sept 2012	23rd June 2012	30th June 2012
Vol. 19 #06	Oct-Nov 2012	20th Aug 2012	27th Aug 2012

AUSTRALIAN EDITION

Print Run: 38,000 Distribution: Australia + S.E. Asia
 Contact: Duncan Roads, NEXUS Magazine
 PO Box 30, Mapleton Qld 4560, Australia.
 Tel: (07) 5442 9280; Fax: (07) 5442 9381
 Email: editor@nexusmagazine.com

UK/EUROPE EDITION

Print Run: 30,000 Distribution: UK + Europe
 Contact: Marcus Allen, NEXUS Magazine (UK)
 55 Queens Rd, E. Grinstead, W. Sussex, RH19 1BG, UK
 Tel: 44 1342 322854; Fax: 44 1342 324574
 Email: nexus@ukoffice.u-net.com

NEW ZEALAND EDITION

Print Run: 10,000 Distribution: NZ + Pacific Islands
 Contact: Lee Brogan, NEXUS Magazine (NZ)
 RD2, Kaeo, Northland, New Zealand.
 Tel: 64 (0)9 405 1963
 Email: nexusnz@xtra.co.nz

USA/CANADA EDITION

Discontinued until further notice.
 Contact: Duncan Roads, NEXUS Magazine
 PO Box 30, Mapleton Qld 4560, Australia.
 Tel: (07) 5442 9280; Fax: (07) 5442 9381
 Email: editor@nexusmagazine.com